



**All support and warranty is handled by TOLIS Group, Inc.**

Warranties are provided by TOLIS Group, Inc. and can be found at:  
[www.tolisgroup.com/documentation.html](http://www.tolisgroup.com/documentation.html)

For warranty, RMA assistance, or technical support help, please visit:  
[www.tolisgroup.com/support.html](http://www.tolisgroup.com/support.html)

# NEOxl 40 Tape Library®

## *Administrator's Guide*

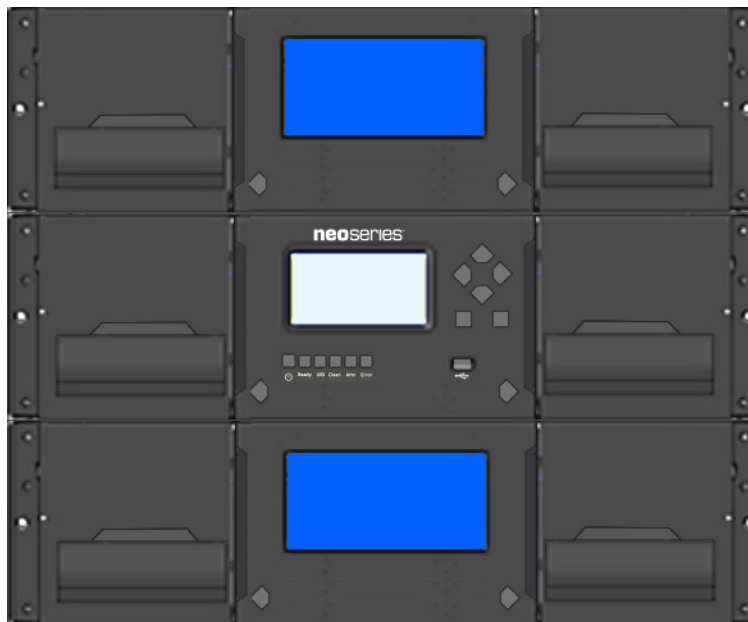

**©2018 Overland Storage, Inc. All rights reserved.**

Overland®, Overland Storage®, Overland-Tandberg®, ARCVault®, DynamicRAID®, GuardianOS®, NEO®, NEO Series®, PowerLoader®, Protection OS®, RAINcloud®, RapidRebuild®, REO®, REO 4000®, REO Series®, Snap Appliance®, Snap Care® (EU only), SnapCLOUD®, Snap ECR® (EU only), SnapExpansion XSR®, SnapSAN®, SnapScale®, SnapScale X2®, SnapScale X4®, SnapServer®, SnapServer XSD Series®, SnapServer XSD40®, SnapServer XSR Series®, SnapServer XSR40®, SnapServer XSR120®, SnapStorage Manager®, VR2®, and XchangeNOW® are registered trademarks of Overland Storage, Inc.

Tandberg®, Tandberg Data®, AccuGuard®, AccuVault®, BizNAS®, DPS1000 Series®, DPS1100®, DPS1200®, DPS2000®, QuadPak®, QuikStation®, QuikStor®, RDX®, RDXPRESS® (EU only), RDXPRO®, SupportSuite® (EU only), RDXPRO®, SupportSuite®, StorageLibrary®, StorageLoader®, Tandberg SecureService, StorageLibrary®, StorageLoader®, Tandberg SecureService®, Tandberg StorageLibrary® (EU only), VXA®, VXA Tape®, and Exabyte® are registered trademarks of Tandberg Data, Inc.

V3® and V3 Desktop Cloud Orchestrator® are registered trademarks of Sphere 3D Corp.

Campus Cluster™, Snap ECR™ (US), Snap Encrypted Continuous Replication™, and SnapSync™ are trademarks of Overland Storage, Inc.

RDX+™ is a trademark of Tandberg Data, Inc.

All other brand names or trademarks are the property of their respective owners.

The names of companies and individuals used in examples are fictitious and intended to illustrate the use of the software. Any resemblance to actual companies or individuals, whether past or present, is coincidental.

**PROPRIETARY NOTICE**

The information contained in this document is subject to change without notice.

All information contained in or disclosed by this document is considered proprietary by Sphere 3D Corp. By accepting this material the recipient agrees that this material and the information contained therein are held in confidence and in trust and will not be used, reproduced in whole or in part, nor its contents revealed to others, except to meet the purpose for which it was delivered. It is understood that no right is conveyed to reproduce or have reproduced any item herein disclosed without express permission from Sphere 3D Corp.

Sphere 3D Corp. provides this manual as is, without warranty of any kind, either expressed or implied, including, but not limited to, the implied warranties of merchantability and fitness for a particular purpose. Sphere 3D Corp. may make improvements or changes in the product(s) or programs described in this manual at any time. These changes will be incorporated in new editions of this publication.

Sphere 3D Corp. assumes no responsibility for the accuracy, completeness, sufficiency, or usefulness of this manual, nor for any problem that might arise from the use of the information in this manual.

Overland Storage, Inc.  
9112 Spectrum Center Blvd.  
San Diego, CA 92123  
U.S.A.

Tel: 1.877.654.3429 (toll-free U.S.)

Tel: +1.858.571.5555, Option 5 (International)

Fax: +1.858.571.0982 (general)

Fax: +1.858.571.3664 (sales)

[www.overlandstorage.com](http://www.overlandstorage.com)



# Preface

## Topics in Preface

- [Audience and Purpose](#)
- [General Warnings](#)
- [Product Warranty Cautions](#)
- [Conventions](#)
- [Regulatory Information](#)
- [Product Documentation & Software Updates](#)
- [Technical Support](#)

## Audience and Purpose

This guide is intended for system and network administrators charged with installing and maintaining a NEOxl 40 Tape Library. It provides information on the installation, configuration, operation, service, and maintenance of the library. Administrators should be familiar with the basic concepts and tasks of network administration.

## Warnings

- Only trained personnel should operate this equipment.
- Read all documentation and procedures before installation or operation.
- Only personnel with technical and product-safety training should be provided access to the library.
- For safety reasons, the default administrator PIN for the Operator Control Panel needs to be changed during initial configuration.
- Hazardous moving parts exist inside this product. Do not insert tools or any parts of your body into the interior of the library while the mailslot or magazine is pulled out.
- Do not insert any tools or any parts of your body into drive bay openings or any other openings of an operating system.

## Avertissement

- Cet équipement ne doit être utilisé que par un personnel formé.
- Lisez la totalité de la documentation et des procédures avant toute installation ou utilisation.
- Ce produit est conçu pour l'installation et l'utilisation dans un rack d'ordinateur avec les portes avant et arrière fermées et sécurisées.
- Seul un personnel avec la formation technique et de sécurité des produits est autorisé à accéder à la bibliothèque.
- Ce personnel est désigné par utilisateurs dans la totalité de ce document.

- Pour des raisons de sécurité, le PIN d'administrateur par défaut doit être changé au cours de la configuration initiale.
- Les pièces mobiles dangereuses existent à l'intérieur de ce produit. N'insérez pas d'outils ni partie du corps dans les ouvertures d'un système en marche.

### Note

- Ventilation – Place the product in a location that does not interfere with proper ventilation.
- Heat – Place the product in a location away from heat sources.
- Power sources – Connect the product to a power source only of the type directed in the operating instructions or as marked on the product.
- Power cord protection – Place the AC line cord so that it is not possible to be walked on or pinched by items placed upon or against it.
- Object and liquid entry – Insure that objects do not fall onto and that liquids are not spilled into the product's enclosure.

### Remarque

- Ventilation – Placez le produit dans un endroit qui n'interfère pas avec une ventilation approprié.
- Chaleur – Placez le produit dans un endroit loin de sources de chaleur.
- Alimentation électrique – Veuillez ne brancher le produit qu'à une source d'alimentation correspondant aux instructions figurant dans le mode d'emploi ou comme directement indiqué sur le produit.
- Protection du cordon d'alimentation – Placez le cordon d'alimentation principal de sorte qu'il ne soit pas possible de marcher dessus ou d'être écrasé par des objets placés sur ou contre.
- Pénétration d'objets et de liquide – S'assurez que des objets ne tombent pas sur le boîtier du produit et que des liquides ne soient pas déversés dans le boîtier du produit.

## General Warnings

### Electrostatic Discharge

To prevent damaging the system, be aware of the precautions you need to follow when setting up the system or handling parts. A discharge of static electricity from a finger or other conductor may damage system boards or other static-sensitive devices. This type of damage may reduce the life expectancy of the device.

**Preventing Electrostatic Damage.** To prevent electrostatic damage, observe the following precautions:

- Avoid hand contact by transporting and storing products in static-safe containers.
- Keep electrostatic-sensitive parts in their containers until they arrive at static-free workstations.
- Place parts on a grounded surface before removing them from their containers.
- Avoid touching pins, leads, or circuitry.
- Always be properly grounded when touching a static-sensitive component or assembly. See the next section.

**Grounding Methods.** There are several methods for grounding. Use one or more of the following methods when handling or installing electrostatic-sensitive parts:

- Use a wrist strap connected by a ground cord to a grounded workstation or computer chassis. Wrist straps are flexible straps with a minimum of 1 megohm ( $\pm 10$  percent) resistance in the ground cords. To provide proper ground, wear the strap snug against the skin.
- Use heel straps, toe straps, or boot straps at standing workstations. Wear the straps on both feet when standing on conductive floors or dissipating floor mats.
- Use conductive field service tools.
- Use a portable field service kit with a folding static-dissipating work mat.

If you do not have any of the suggested equipment for proper grounding, have an authorized reseller install the part. For more information on static electricity, or assistance with product installation, contact your authorized reseller.

## Product Warranty Cautions

The customer should only perform the service and repair actions on the tape library components as described in this document. Any other actions needed should only be performed by an authorized service center.



The warranty for the tape library shall not apply to failures of any unit when:

- The tape library is repaired or modified by anyone other than the manufacturer's personnel or approved agent.
- The tape library is physically abused or used in a manner that is inconsistent with the operating instructions or product specification defined by the manufacturer.
- The tape library fails because of accident, misuse, abuse, neglect, mishandling, misapplication, alteration, faulty installation, modification, or service by anyone other than the factory service center or its approved agent.
- The tape library is repaired by anyone, including an approved agent, in a manner that is contrary to the maintenance or installation instructions supplied by the manufacturer.
- The manufacturer's serial number tag is removed.
- The tape library is damaged because of improper packaging on return.

Warranty becomes immediately void in the event of unauthorized repairs or modifications.

## Conventions

This document exercises several alerts and typographical conventions.

Convention	Description & Usage
 <b>WARNING</b>	A <i>Warning</i> contains information concerning personal safety. Failure to follow directions in the Warning could result in bodily harm or death.
<b>WARNUNG</b>	Eine <i>Warnung</i> enthält Informationen zur persönlichen Sicherheit. Das Nichtbeachten der Anweisungen in der Warnung kann zu Verletzungen oder zum Tod führen.
<b>AVERTISSEMENT</b>	Un <i>avertissement</i> contient des informations relatives à la sécurité personnelle. Ignorer les instructions dans l'avertissement peut entraîner des lésions corporelles ou la mort.
 <b>CAUTION</b>	A <i>Caution</i> contains information that the user needs to know to avoid damaging or permanently deleting data or causing physical damage to the hardware or system.
 <b>IMPORTANT</b>	An <i>Important</i> note is a type of note that provides information essential to the completion of a task or that can impact the product and its function.
<b>Item_name</b>	Words in this special boldface font indicate the names of buttons or pages found in the Operator Control Panel display or a Remote Management Interface page.
Ctrl+Alt+s	This type of format details the keys you press simultaneously. In this example, hold down the <b>Ctrl</b> and <b>Alt</b> keys and press the lowercase <b>s</b> key.
NOTE	A <i>Note</i> indicates neutral or positive information that emphasizes or supplements important points of the main text. A note supplies information that may apply only in special cases, for example, memory limitations or details that apply to specific program versions.
Menu Flow Indicator (>)	Words with a greater than sign between them indicate the flow of actions to accomplish a task. For example, <b>Setup &gt; User &gt; Password</b> indicates that you should click the <b>Setup</b> tab, then the <b>User</b> secondary tab, and finally the <b>Password</b> button to accomplish a task.
<i>Courier Italic</i>	A variable for which you must substitute a value.
<b>Courier Bold</b>	Commands you enter in a command-line interface (CLI).

Information contained in this guide has been reviewed for accuracy, but not for product warranty because of the various environments, operating systems, or settings involved. Information and specifications may change without notice.

## Regulatory Information

### Disposal of Waste Equipment by Users in Private Households in the European Union and Norway



This symbol on the product or on its packaging indicates that this product must not be disposed of with your other household waste. Instead, it is your responsibility to dispose of your equipment by handling it over to a designated collection point for the recycling of waste electrical and electronic equipment. The separate collection and recycling of your waste equipment at this time of disposal will help to conserve natural resources and ensure that it is recycled in a manner that protects human health and the environment. For more information about where you can drop off your waste equipment for recycling, please contact your local city office, your household waste disposal service, or the shop where you purchased the product.

### CE Mark

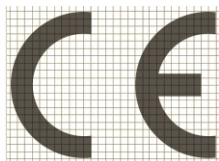

The CE mark is a mandatory conformity mark on many products placed on the single market in the European Economic Area (EEA). The CE marking certifies that a product has met EU consumer safety, health or environmental requirements.

### CCL Mark



CSA C22-2 No. 60950-1 – Electrical safety – UL 60950-1  
68475

### FCC (United States)



The computer equipment described in this manual generates and uses radio frequency (RF) energy. If the equipment is not installed and operated in strict accordance with the manufacturer's instructions, interference to radio and television reception might result.

This equipment complies with Part 15 of the FCC Rules. Operation is subject to the following conditions: (1) This device may not cause harmful interference, and (2) this device must accept any interference received, including interference that may cause undesired operation.

Part 15, Class A, of the FCC Rules, is designed to provide reasonable protection against radio and television interference in a residential installation. Although the equipment has been tested and found to comply with the allowed RF emission limits, as specified in the above-cited Rules, there is no guarantee that interference will not occur in a particular installation. Interference can be determined by turning the equipment off and on while monitoring radio or television reception. The user may be able to eliminate any interference by implementing one or more of the following measures:



- Reorient the affected device and/or its receiving antenna.
- Increase the distance between the affected device and the computer equipment.
- Plug the computer and its peripherals into a different branch circuit from that used by the affected device.
- If necessary, consult an experienced radio/television technician for additional suggestions.

## Canadian Verification

This Class A digital apparatus meets all requirements of the Canadian Interference-Causing Equipment Regulations (ICES-003, Class A).

## Product Documentation & Software Updates

NEOx1 40 Tape Library product documentation is available at the Overland-Tandberg Knowledge Base:

<https://community.sphere3d.com/community/documentation>

The latest release of the tape library firmware and other software is available online:

<http://support.overlandstorage.com/support/neo-series.htm>

## Technical Support

For warranty and general technical support information, see our [Contact Us](#) web page:

<http://www.overlandstorage.com/company/contact-us/index.aspx>

For information on contacting Overland-Tandberg Technical Support, see our [Contact Support](#) web page:

<http://support.overlandstorage.com/support/contact.htm>

To search for more service information, visit our [Knowledge Bases](#):

<https://community.sphere3d.com/welcome>



# Contents

## Preface

## Chapter 1: Overview

Supported Configurations .....	15
Rackmount Configurations .....	15
Configurations with Legacy Serial ADI Drive Sleds .....	17
Supported Tape Drives .....	17
Module Front Panels .....	18
Base Module Front Panel .....	18
Expansion Module Front Panel .....	18
Module Rear Panels .....	19
Base Module Rear Panel .....	19
Expansion Module Rear Panel .....	19
Drive Sled Back Panels .....	20
Power Supply Rear Panel LEDs .....	21
Element Numbering .....	21
Tape Cartridges .....	22
Read and Write Compatibility .....	22
Using and Maintaining Tape Cartridges .....	22
Labeling Tape Cartridges .....	23
Write Protecting Tape Cartridges .....	24

## Chapter 2: Installation

Planning the Installation .....	25
Location Requirements .....	25
Bus Interface .....	26
Planning Module and Rack Layout .....	27
Internal IP Range Selection .....	27
Installation Precautions .....	28
Warnings: .....	28
Poids du produit: .....	28
Static Sensitive .....	29
Électricité statique .....	29
Moisture .....	29
Module Preparation .....	29
Library Module Components .....	29
Preparing Top and Bottom Modules .....	29
Installing Modules in a Rack .....	31
Install the Rack Rails .....	31
Insert the Modules in the Rack .....	32
Aligning and Connecting Modules .....	33
Installing Tape Drives .....	34

Connecting Fibre Channel Cables .....	35
Connecting SAS Cables .....	35
Final Connections .....	35

### Chapter 3: Initial Setup

Powering On the Library .....	37
Initial Setup Using the OCP Wizard .....	38
Complete Setup Using the RMI .....	38
Verifying the Host Connection .....	38
Loading Tape Cartridges .....	39
Labeling Tape Cartridges .....	39
Using the Mailslot to Load Tape Cartridges .....	39
Bulk Loading Magazines .....	40
Verifying the Installation .....	41
Configuring Additional Features .....	41
Enabling and Configuring SNMP Network Management .....	41
Email Event Notification .....	41
Modifying the Default Tape Drive Settings .....	41
Enabling the Mailslot .....	41
Configuring Partitioning .....	41

### Chapter 4: Basic Library Operation

User Levels .....	42
OCP Library Operation .....	43
OCP Home Screen .....	44
OCP Menu .....	44
Log Into The Library (OCP) .....	45
RMI Library Operations .....	46
Log Into The Library (RMI) .....	47
Manual Tape Magazine Access .....	47

### Chapter 5: Operator Control Panel

Change Settings Procedure .....	50
Operation Menu .....	50
Move Media .....	51
Move Cartridge from Drive to Home Slot .....	51
Inventory Scan .....	52
Configuration Menu .....	53
Initial System Setup .....	53
Date and Time Configuration .....	55
Network Settings .....	56
Drive Power On/Off .....	56
User Accounts .....	57
Save/Restore .....	58
Maintenance Menu .....	61
Library Tests .....	61
View Events .....	64
Drive Logs Download .....	65
Library Logs Download .....	65
Drive Firmware Upgrade .....	65

Library Firmware Upgrade .....	66
LCD Adjustment .....	67
SSH (Secure Shell) .....	68
Status Menu .....	68
Network Settings (Status) .....	69
Library (Status) .....	69
Drive (Status) .....	70
Logout .....	71

## Chapter 6: Remote Management Interface

Home Page Element Details .....	73
RMI Top Banner Elements .....	73
RMI Left Pane Elements .....	73
RMI Center Pane Elements .....	74
RMI Right Pane Elements .....	74
RMI Configuration Options .....	76
Initial Configuration Wizard .....	76
System Configuration .....	77
Network Configuration .....	81
Network Management .....	83
Tape Drive Configuration .....	87
Mailslot Configuration .....	88
Partition Configuration .....	88
Encryption Configuration .....	93
User Accounts Configuration .....	93
Web Management Configuration .....	96
RMI Maintenance Options .....	99
Library Tests .....	99
View Logs and Traces .....	104
Firmware Upgrades .....	105
Download Drive Logs .....	107
System Reboot .....	108
Drive Reboot .....	108
UID LED Control .....	108
Move Robotic to Base Module .....	109
Support Information .....	109
RMI Operation Options .....	109
Moving Media .....	110
Open Mailslot .....	111
Open a Magazine .....	111
Clean a Tape Drive .....	112
Rescan Cartridge Inventory .....	112
Force a Drive to Eject a Cartridge .....	112
RMI Status Options .....	113
Library and Module Status .....	113
Cartridge Inventory Views .....	115
Partition Map Views .....	118
Drive Status .....	121
Network Status .....	122
Security Status .....	123

## Chapter 7: Service and Upgrades

Identify a Failed Component .....	126
Install or Replace a Tape Drive .....	126
Remove a Tape Drive .....	126
Remove a Drive Bay Cover .....	127
Install a Tape Drive .....	128
Connect the Drive Cables .....	128
Verify the Installation .....	129
Replace a Power Supply .....	129
Identify the Failed Component .....	129
Prepare to Remove the Power Supply .....	129
Remove the Power Supplies .....	130
Install the New Power Supply .....	130
Verify the Power Supply Installation and Operation .....	130
Replace a Controller Board .....	131
Identify the Failed Component .....	131
Save the Configuration .....	131
Power Off the Library .....	131
Prepare to Remove the Controller .....	131
Remove the Controller .....	132
Install the Controller .....	132
Verify the Controller Installation .....	132
Power On the Library .....	133
Install or Replace a Drive Power Board .....	133
Identify the Failed Component .....	133
Power Off the Library .....	133
Prepare to Remove the Drive Power Board .....	133
Remove the Library/Expansion Controller and Drive Power Boards .....	133
Install the New Drive Power Board .....	134
Power On the Library .....	134
Verify the Drive Power Board Installation .....	134
Adding an Expansion Module .....	135
Overview .....	135
Power Off the Library .....	135
Move a Cover to the New Module .....	135
Install the Module in the Rack .....	135
Align and Connect the Module .....	135
Verify the Installation and Configuration .....	136
Replace a Module (Base or Expansion) .....	136
Save the Configuration .....	136
Prepare Module for Removal .....	136
Remove Module from Rack .....	139
Move Covers and Components .....	140
Insert the Module in Rack .....	142
Complete the Installation .....	144
Verify the Library Configuration .....	145
Move a Tape Library .....	145
Replace the Robotic Assembly and Spooling Mechanism .....	146
Prepare Module for Removal .....	146
Remove Module from Rack .....	148
Remove Top Cover .....	149

Remove Old Robotic Assembly .....	150
Install the New Robotic Assembly .....	152
Reinstall the Cover .....	154
Reinsert the Module in Rack .....	154
Aligning and Connecting the Module .....	155
Complete the Reinstallation .....	155
Reinstall Tape Magazines .....	156
Verify the Library Configuration .....	157
Replace the Base Module Front Bezel/OCP .....	157
Power Off the Library .....	158
Remove the Tape Magazines .....	158
Remove the Bezel .....	158
Install the Bezel .....	159
Reinstall Tape Magazines .....	159
Power On the Library .....	159

## Appendix A: Troubleshooting

Fibre Channel Connection Problems .....	160
Detection Problems After Installing a SAS Drive .....	161
Operational Problems .....	162
Power Problems .....	162
OCP Alerts and Errors .....	162
Tape Movement Problems .....	163
Media Problems .....	164
Attn LED is Lit .....	164
Inventory Problems .....	165
RMI Network Connection Problems .....	165
Cleaning Problems .....	166
Performance Problems .....	166
Average File Size .....	166
File Storage System .....	166
Connection from the Backup/Archive Host Server to the Disk Array .....	167
Backup/Archive Server .....	167
Backup/Archive Software and Method .....	167
Connection from the Archive/Backup Host Server to the Library .....	167
Media .....	168
Finding Event Information .....	168
Unlocking a Magazine .....	168
Using the Magazine Unlock Buttons .....	168
Using the RMI to Unlock Magazines .....	169
Using the Magazine Manual Release .....	169
Unloading a Stuck Tape .....	170
Returning the Robotic Assembly to the Base Module .....	170
Robotic Assembly Stopped Near Base Module or Between Modules .....	170
Robotic Assembly Stopped Far From Base Module or Cannot Move Vertically .....	171
Running Library Tests .....	171

## Appendix B: Event Codes and Acronyms

Event Codes .....	173
Warning Events .....	179
Configuration Change Events .....	184

Informational Events .....	186
Acronyms and Abbreviations .....	187

## **Appendix C: Technical Specifications**

Physical Specifications .....	188
Environmental Specifications .....	188
Electrical Specifications .....	189
Regulatory Specifications (CSA test conditions) .....	189
Default Settings .....	190

## **Master Glossary & Acronym List**

## **Index**

# 1

## Overview

All NEOxl 40 Tape Library installations begin with the 3U-high Base Module with capacity for 32 tape cartridges and 3 half-height LTO tape drives.

The NEOxl 40 Tape Library is expandable, allowing a user to grow their tape storage capacity as their data requirements increase. As data storage needs grow, the NEOxl 40 Tape Library can also grow by adding one or more 3U-high Expansion Modules. Each Expansion Module provides an additional 40 tape cartridge slots and supports an additional 3 half-height LTO tape drives.

**NOTE:** The bottom module is limited to 32 cartridges while all the modules above, regardless of the type, supports a full 40 cartridges.

Up to six Expansion Modules can be added to a Base Module (three above and three below), bringing the total library capacity to 272 tape cartridges and 21 half-height LTO tape drives.

### Topics in Overview:

- [Supported Configurations](#)
- [Module Front Panels](#)
- [Module Rear Panels](#)
- [Drive Sled Back Panels](#)
- [Power Supply Rear Panel LEDs](#)
- [Element Numbering](#)
- [Module Front Panels](#)

## Supported Configurations





A NEOxl 40 Tape Library can be configured as rackmount library consisting of a Base Module and Expansion Modules.

### Rackmount Configurations

A rack mounted NEOxl 40 Tape Library starts with a Base Module with up to six Expansion Modules added as needed (three Expansion Modules above and three Expansion Modules below). For a full stack to be installed, the Base Module must be mounted with 9U of empty space above and 9U of empty space below. The table below shows the supported configurations for libraries ranging from one to seven total modules.

Module Quantity	Supported Configurations
1-Module Library (Base Module only)	

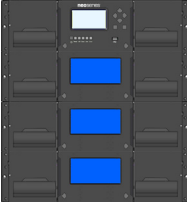
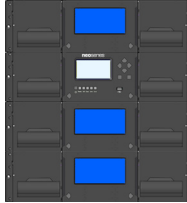
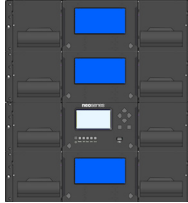
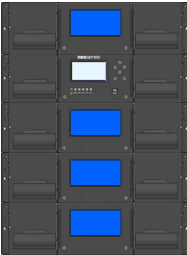
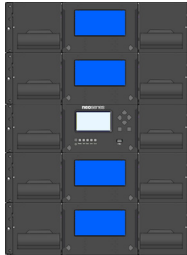
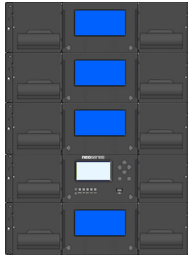
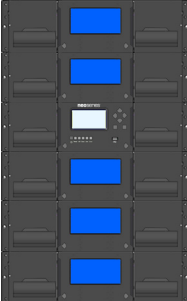
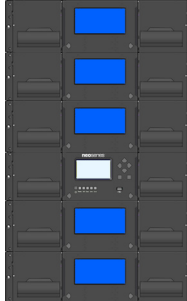

Module Quantity	Supported Configurations		
<b>2-Module Library (Base Module + 1 Expansion Module)</b>			
<b>3-Module Library (Base Module + 2 Expansion Modules)</b>			
<b>4-Module Library (Base Module + 3 Expansion Modules)</b>			
<b>5-Module Library (Base Module + 4 Expansion Modules)</b>			
<b>6-Module Library (Base Module + 5 Expansion Modules)</b>			

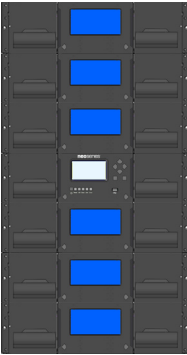
Module Quantity	Supported Configurations
7-Module Library (Base Module + 6 Expansion Modules)	

### Configurations with Legacy Serial ADI Drive Sleds

The NEOxl 40 Tape Library supports serial ADI drive sleds. One Drive Power Board (DC-DC converter) is required in each module that includes one or more drives. The following table describes the supported serial ADI configurations for each module type – Base Module and Expansion Modules.

Module Type	Power Supplies	Drive Power Board	Tape Drives
Base	1 (standard) or 2 (redundant configuration)	1 (standard)	Up to 3
Expansion (without Tape Drives)	0 (standard)	0 (standard)	0
Expansion (with Tape Drives)	1 (required) or 2 (redundant configuration)	1 (required)	Up to 3

### Supported Tape Drives

The NEOxl 40 Tape Library was developed to integrate industry-standard LTO Ultrium tape drives from IBM. Mixed drive generations and mixed interfaces are supported within a single library and within a single module.

Listed below are the tape drives that have been implemented and qualified for use in the NEOxl 40 Tape Library.

IBM LTO Drives
LTO-7 Half-Height FC Single Port
LTO-7 Half-Height FC Dual Port
LTO-7 Half-Height SAS Dual Port
LTO-8 Half-Height FC Single Port
LTO-8 Half-Height FC Dual Port
LTO-8 Half-Height SAS Dual Port

# Module Front Panels

The following is a breakdown of the front panels for the Base Module and the Expansion Module.

## Base Module Front Panel

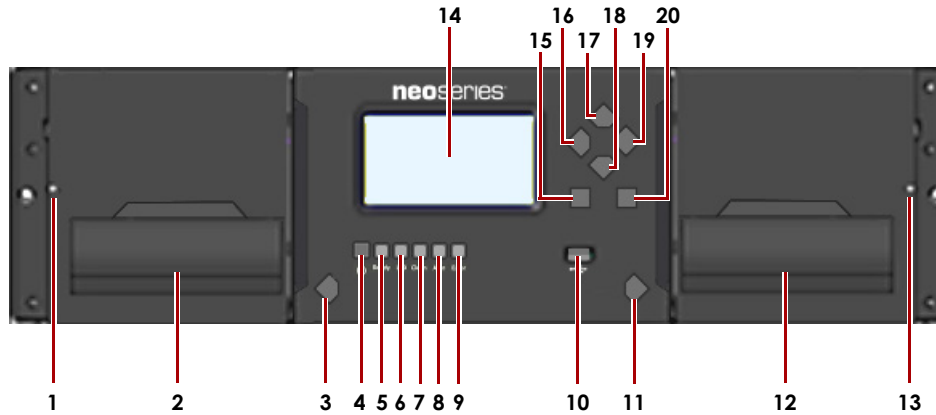

- |   |   |
|---|---|
| 1 Left Magazine Emergency Release Access Hole | 11 Right Magazine Release                       |
| 2 Left Magazine Access Handle                 | 12 Mailslot/Right Magazine Access Handle        |
| 3 Left Magazine Release                       | 13 Right Magazine Emergency Release Access Hole |
| 4 Power Button                                | 14 Operator Control Panel (OCP) Display         |
| 5 Ready LED, Green                            | 15 Back/Return Button                           |
| 6 Unit Identification LED, Blue               | 16 Navigation Button - Left                     |
| 7 Clean LED, Amber                            | 17 Navigation Button - Up                       |
| 8 Attn LED, Amber                             | 18 Navigation Button - Down                     |
| 9 Error LED, Amber                            | 19 Navigation Button - Right                    |
| 10 USB Port                                   | 20 Enter Button                                 |

## Expansion Module Front Panel

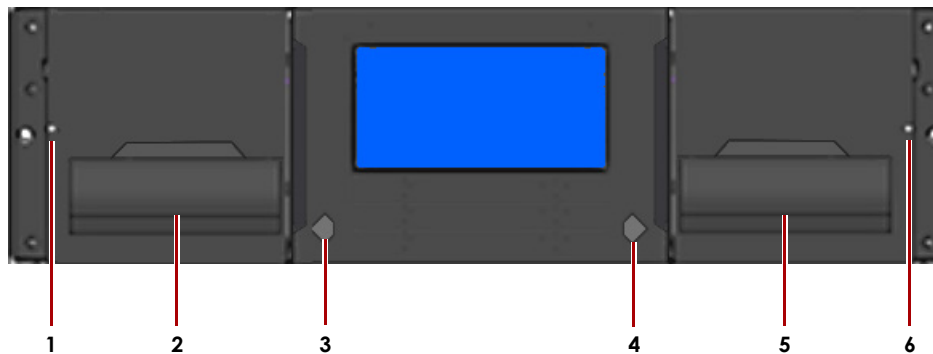

- |   |  |
|---|--|
| 1 Left Magazine Emergency Release Access Hole | 4 Right Magazine Release                       |
| 2 Left Magazine Access Handle                 | 5 Right Magazine/Mailslot Access Handle        |
| 3 Left Magazine Release                       | 6 Right Magazine Emergency Release Access Hole |

## Module Rear Panels

The following is a breakdown of the rear panels for the Base Module and the Expansion Module.

### Base Module Rear Panel

The USB, MGMT, and DIAG ports are only on the Base Module. The DC-DC Drive Power Board is located inside behind the Controller panel.

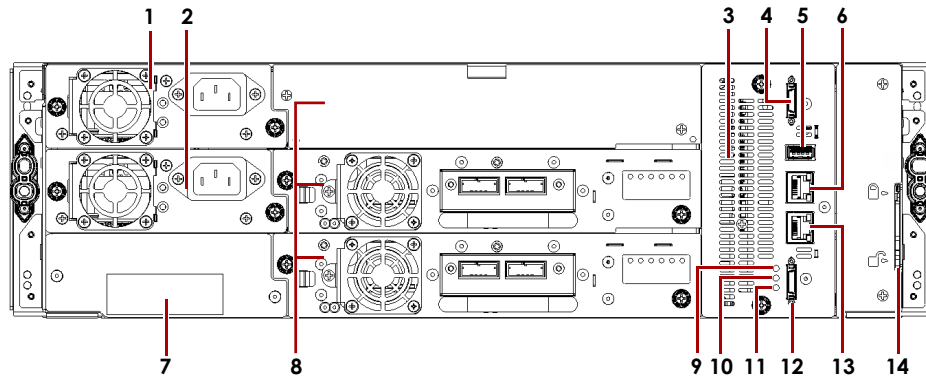

- |   |  |
|---|--|
| 1 Power Supply Bay 1                                      | 8 Half Height Tape Drive Bays            |
| 2 Power Supply Bay 2                                      | 9 Health Status LED, Green               |
| 3 Controller (Drive Power Board inside)                   | 10 Error LED, Amber                      |
| 4 Upper Expansion Cable Connection Port                   | 11 Unit Identifier (UID) LED, Blue       |
| 5 USB Port*   | 12 Lower Expansion Cable Connection Port |
| 6 Ethernet DIAG Port (CVTL Data Verification Connection)* | 13 Ethernet MGMT Port (RMI Connection)*  |
| 7 Module Serial Number Tag Location                       | 14 Module Alignment Lever                |

\* Base Module Only

### Expansion Module Rear Panel

The Expansion Module Controller panel does not have USB, MGMT, and DIAG ports. The optional DC-DC Drive Power Board is located inside behind the Controller panel.

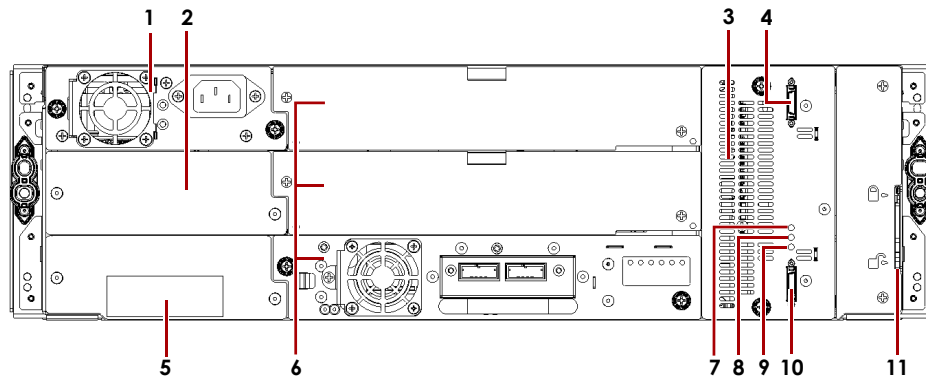

- |  |                                   |
|--|-----------------------------------|
| 1 Power Supply Bay 1 (PSU optional)              | 7 Health Status LED, Green        |
| 2 Power Supply Bay 2 (PSU optional)              | 8 Error LED, Amber                |
| 3 Controller (optional Drive Power Board inside) | 9 Unit Identifier (UID) LED, Blue |

- |  |   |
|--|---|
| <b>4</b> Upper Expansion Cable Connection Port         | <b>10</b> Lower Expansion Cable Connection Port |
| <b>5</b> Module Serial Number Tag Location             | <b>11</b> Module Alignment Lever                |
| <b>6</b> Half Height Tape Drive Bays (drives optional) |   |

## Drive Sled Back Panels

### IBM LTO-7/8 HH SAS ADI Dual Port

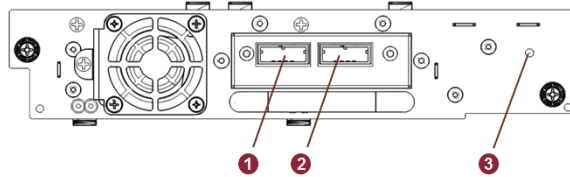

- 1 SAS Port A
- 2 SAS Port B
- 3 Tape Drive Power LED, Green

### IBM LTO-7/8 HH FC ADI Single Port

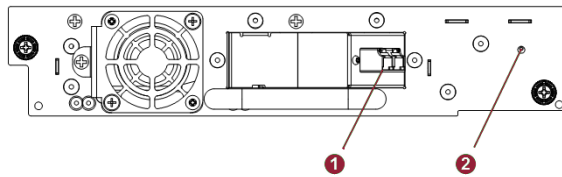

- 1 FC Port A
- 2 Tape Drive Power LED, Green

### IBM LTO-7/8 HH FC ADI Dual Port

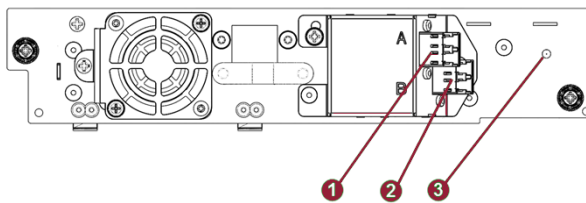

- 1 FC Port A
- 2 FC Port B
- 3 Tape Drive Power LED, Green

## Power Supply Rear Panel LEDs

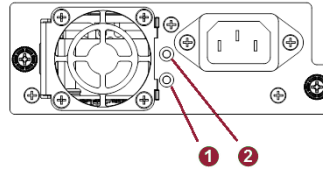

- 1 Module powered ON, green
- 2 AC power connected, white

## Element Numbering

The library displays logical element numbering of modules, storage slots, and tape drives starting with number one from the bottom up.

**Numbering Example:**

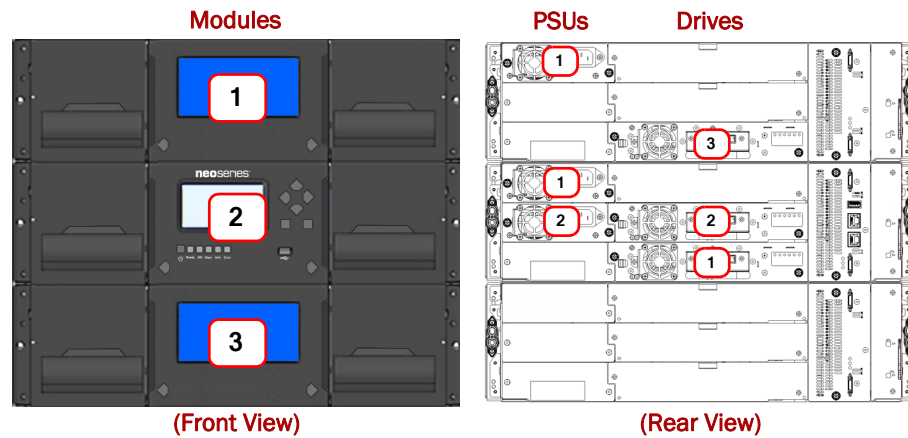

Module Numbering	Power Supply Numbering	Tape Drive Numbering
Module 1 (Expansion)	Power Supply 1	(empty)
	(empty)	Drive 3
	(S/N plate)	(empty)
Module 2 (Base)	Power Supply 1	(empty)
	Power Supply 2	Drive 2
	(S/N plate)	Drive 1
Module 3 (Expansion)	(empty)	(empty)
	(empty)	(empty)
	(S/N plate)	(empty)

## Tape Cartridges

Use the Ultrium data and cleaning tape cartridges designed for your library based on the type of tape drives used.

LTO-7 Tape Drive	LTO-8 Tape Drive
LTO-7 Ultrium 15TB* Data Cartridge	LTO-7 Type M Ultrium 22.5TB* Data Cartridge
LTO-7 Ultrium 15TB* WORM Data Cartridge	LTO-8 Ultrium 30TB* Data Cartridge
	LTO-8 Ultrium 30TB* WORM Data Cartridge
<b>Ultrium Universal Cleaning Cartridge (50 Cleans)</b>	Ultrium Universal Cleaning Cartridge (50 Cleans)

\*Using a 2.51 compression factor.

### Read and Write Compatibility

	LTO-7 Drive	LTO-8 Drive
LTO-5 Media, Unencrypted	Read Only	Incompatible
LTO-5 Media, Encrypted	Read/only with encryption key	Incompatible
LTO-6 Media, Unencrypted	Read/Write	Incompatible
LTO-6 Media, Encrypted	Read/Write with encryption key	Incompatible
LTO-7 Media, Unencrypted	Read/Write	Read/Write
LTO-7 Media, Encrypted	Read/Write with encryption key	Read/Write with encryption key
LTO-7 Type M Media, Unencrypted	Incompatible	Read/Write
LTO-7 Type M Media, Encrypted	Incompatible	Read/Write with encryption key
LTO-8 Media, Unencrypted	Incompatible	Read/Write
LTO-8 Media, Encrypted	Incompatible	Read/Write with encryption key

### Using and Maintaining Tape Cartridges



**CAUTION:** Do not degauss LTO data cartridges! These data cartridges are pre-recorded with a magnetic servo signal. This signal is required to use the cartridge with the LTO tape drive. Keep magnetically charged objects away from the cartridge.

To ensure the longest possible life for your data cartridges, follow these guidelines:

- Use only the data cartridges designated for your device.
- Clean the tape drive only when the Clean Drive LED is illuminated.



**CAUTION:** Use only Ultrium Universal cleaning cartridges.

- Do not drop a cartridge. Excessive shock can damage the internal contents of the cartridge or the cartridge case itself, making the cartridge unusable.
- Do not expose data cartridges to direct sunlight or sources of heat, including portable heaters and heating ducts.
- The operating temperature range for data cartridges is 10 to 35° C. The storage temperature range is -40 to +60° C in a dust-free environment in which relative humidity is always between 20 percent and 80 percent (non-condensing).
- If the data cartridge has been exposed to temperatures outside the specified ranges, stabilize the cartridge at room temperature for the same length of time it was exposed to extreme temperatures or 24 hours, whichever is less.
- Do not place data cartridges near sources of electromagnetic energy or strong magnetic fields such as computer monitors, electric motors, speakers, or X-ray equipment. Exposure to electromagnetic energy or magnetic fields can destroy data and the embedded servo code written on the media by the cartridge manufacturer, which can render the cartridge unusable.
- Place identification labels only in the designated area on the cartridge.

## Labeling Tape Cartridges

The device contains a barcode reader that reads the tape labels and stores the inventory data in memory. The device then provides the inventory information to the host application, OCP, and RMI. Having a barcode label on each tape cartridge enables the barcode reader to identify the cartridge quickly, thereby speeding up inventory time. Make it a practice to use barcode labels on your tape cartridges.

A proper barcode label includes the media ID in the last two characters of the barcode. The library will not load an incompatible cartridge, based on the barcode media ID, into a tape drive. For example, the library will not load a cartridge labeled as LTO-3 into an LTO-6 tape drive. This saves the time needed to load the cartridge and have the tape drive reject it.

Your host software may need to keep track of the following information via the associated barcode:

- Date of format or initialization
- Tape's media pool
- Data residing on the tape
- Age of the backup
- Errors encountered while using the tape (to determine if the tape is faulty)



**IMPORTANT:** Misusing and misunderstanding barcode technology can result in backup and restore failures. Use only high quality labels. Self-printed labels are not recommended as they are often a source of barcode reading issues.

---



LTO tape cartridges have a recessed area located on the face of the cartridge next to the write-protect switch. Use this area for attaching the adhesive-backed barcode label. Only apply labels as shown:

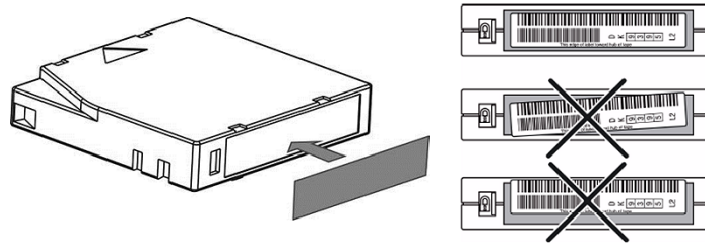

**IMPORTANT:** The barcode label should only be applied as shown, with the alphanumeric portion facing the hub side of the tape cartridge. Never apply multiple labels onto a cartridge because extra labels can cause the cartridge to jam in a tape drive.

## Write Protecting Tape Cartridges

All rewritable data cartridges have a write-protect switch to prevent accidental erasure or overwriting of data. Before loading a cartridge into the device, make sure the write-protect switch on the front of the cartridge is in the desired position.

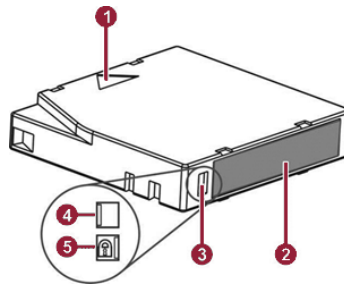

- 1 Insertion Embossed Arrow
- 2 Barcode Label
- 3 Write-Protect Switch
- 4 Write-Enabled Position (Blank)
- 5 Write-Protected Position with Lock Icon

Switch positions:

- Slide the switch to the **left** to allow the device to write data to the cartridge.
- Slide the switch to the **right** to write-protect the cartridge. An indicator, such as a red mark or small padlock, is visible showing that the cartridge is write-protected.

# 2

## Installation



**WARNING:** To avoid injury, we recommend the use of a mechanical lifting aid (or at least two persons) for rack installation or removal. Use caution during rack installation or removal to avoid accidentally tilting or tipping the rack or injuring yourself. To reduce the risk of electric shock or damage to equipment, always remove any power cords while working with the equipment.

**WARNUNG:** Um Verletzungen zu vermeiden, empfehlen wir zur Rack-Installation oder -Deinstallation die Nutzung einer mechanischen Hebehilfe (oder mindestens zwei Personen). Seien Sie vorsichtig bei der Rack-Installation oder -Entnahme, um ein versehentliches Kippen des Racks zu vermeiden und das Rack nicht zu beschädigen bzw. sich selbst zu verletzen. Um das Risiko eines elektrischen Schlags oder Schäden am Gerät zu vermeiden, ziehen Sie stets den Netzstecker, bevor Sie an der Einheit arbeiten.

**AVERTISSEMENT:** Afin d'éviter des blessures pendant l'installation, il est recommandé d'utiliser un monte-charge (ou au moins deux personnes) pour élever ou aligner l'module. Faites attention lorsque vous insérez ou retirez l'module d'un support, pour empêcher le déversement accidentel de la crémaillère causant des dommages et des blessures. Pour réduire le risque de choc électrique ou endommagement de l'équipement, retirez toujours les cordons électriques en travaillant avec l'équipement.

### Topics in Installation:

- [Planning the Installation](#)
- [Installation Precautions](#)
- [Module Preparation](#)
- [Installing Modules in a Rack](#)
- [Installing Tape Drives](#)
- [Final Connections](#)

## Planning the Installation

These four planning steps are necessary to install your NEOxl 40 Tape Library:

- Choose a location for the library.
- Plan the SAS or Fibre Channel configuration and obtain the necessary cables.
- For rack installations, plan the rack layout.
- Select the Internal IP range.

### Location Requirements

The library was designed for rack installation and must use the provided rack rails.

Select a location with access to the host server that meets the criteria in the table below.

Criteria	Definition
<b>Rack Requirements</b>	Standard 19-inch rack (minimum depth of 1 meter) with an appropriate number of Rack Units of clearance for the planned module quantity.
<b>Rack Space Requirements</b>	3U for the Base Module plus 3U for each Expansion Module.
<b>Room Temperature</b>	10-35° C (50-95° F)
<b>Power Source</b>	<ul style="list-style-type: none"> <li>• AC power voltage: 100-240 VAC</li> <li>• Line frequency: 50-60 Hz</li> <li>• Library located near AC Outlets</li> </ul> <p>The AC power cord is the library's main AC disconnect device and must be easily accessible at all times.</p>
<b>Air Quality</b>	<ul style="list-style-type: none"> <li>• Place the library in an area with minimal sources of particulate contamination.</li> <li>• Avoid areas near frequently used doors and walkways, stacks of supplies that collect dust, printers, and smoke-filled rooms.</li> <li>• Excessive dust and debris can damage tapes and tape drive.</li> </ul>
<b>Humidity</b>	20% to 80% RH non-condensing.

## Bus Interface

Plan either for a SAS or Fibre Channel configuration, determine the parameters to be used (such as speed) and obtain the necessary cables.

### SAS Configuration Requirements

Serial Attached SCSI (SAS) is a computer bus technology mainly used to transfer data to and from storage devices, including disk drives and tape drives. Supported SAS speeds by all tape drives are 1.5 Gbps, 3 Gbps, and 6 Gbps.

SAS uses serial connections, with a direct connection between the host server and each of the storage devices. This eliminates the need to configure SCSI buses and assign SCSI IDs, as is required for parallel SCSI devices.

The host server must have a SAS Host Bus Adapter (HBA) with an external connector. The HBA uses multiple Logical Unit Numbers (LUNs) to communicate with the library. Verify that your HBA supports multiple LUNs, as most RAID controllers do not. Most SAS HBA ports have four SAS channels. A tape drive uses one channel, so each HBA port can support up to four tape drives. You can use a cable with one connector on each end, but only one channel will be used.



**CAUTION:** High quality SAS cables rated at the transfer rate the SAS drives are required. Always verify that the SAS cable you are using is rated for the data transfer speed of the interface of your components. SAS cables described as “equalized” may not support 6 Gb/s data rates and should not be used with LTO-5 or later generation tape drives unless these cables are verified for 6 Gb/s data rates.

The library has one or more mini-SAS connectors on each SAS tape drive. Mini-SAS connectors are keyed. Do not force a SAS cable's mini-SAS connector into the tape drive as it might be keyed differently.

A SAS tape drive is identified by a unique identifier called a World Wide Name (WWN) or World Wide Identifier (WWID). The library assigns the WWID to the drive bay. When a tape drive is replaced, the WWID is re-assigned to the new tape drive.

The operating system tracks the WWID for the tape drive on each HBA channel. Each of the drive connectors on the fan-out cable is associated with an HBA channel. Once a tape drive has been plugged in, it should remain on the same channel to retain the association between the HBA channel and WWID.

### Fibre Channel Configuration Requirements

The Fibre Channel (FC) tape drive can be connected directly to the server with a Host Bus Adapter (HBA) or through a storage area network (SAN).

The installation requires one Fibre Channel cable for each tape drive. The tape drives all utilize an LC-style connector. Some drives have two FC ports, but only one cable connection is needed per drive. The cable can be connected to either drive FC port.

Supported speeds by all tape drives are 2 Gbps, 4 Gbps, and 8 Gbps.



**IMPORTANT:** Use an appropriate HBA for your tape drive due to performance requirements. A lower Gbps HBA might result in performance degradation when moving highly compressible data to a higher Gb tape drive. In a SAN installation, all switches between the host and the library must be of the appropriate type. A lower Gb switch in the path may result in performance degradation. Configure zoning so only the backup servers may access the library.

## Planning Module and Rack Layout

If possible, install the Base Module in the middle of the rack to provide space for the permitted three Expansion Modules above and three Expansion Modules below. See [Chapter 1, "Supported Configurations,"](#) for additional details.

## Internal IP Range Selection

For internal communication between modules the tape library uses an Ethernet connection with an internal IP address range. To prevent any conflict between the internal IP address range and the external IP addresses it is required to select the internal IP range before the tape library gets connected to the external Ethernet port.

A file which contains the internal IP range is stored onto the Base Module backplane.

The values must be in the format "RANGE=192.0.2".

**NOTE:** The last section of the IP address is not set because it is set internally.

The file is created through the Operator Control Panel (OCP) IP Range selection screen when the Stack starts for the very first time or if the unit was reset to Manufacturing Defaults / Reset via OCP or Remote Management Interface (RMI).

Follow these general guidelines:

- Check with a system administrator before powering off the host computer.
- For a SAS library, confirm availability or install a SAS HBA that supports multiple LUNs.
- For a direct-attach Fibre Channel library, confirm availability of install an FC HBA.
- For connection of a Fibre Channel library through a compatible switch, verify that sufficient ports are available.

## Installation Precautions

### Warnings:

**Product weight.** Each NEOxl 40 module weighs more than 44 lbs. (20kg) without drives or tapes and more than 77 lbs. (35kg) with three tape drives and 40 tapes. Before moving or lifting the module, remove the tape magazines and drives to reduce the weight.

**Risk of personal injury.** Before moving or lifting a module:

- Observe local health and safety requirements and guidelines for manual material handling.
- Remove all tapes to reduce the weight and to prevent cartridges from falling into the robotics path and damaging the library.
- Remove all tape drives to reduce the weight.
- Obtain adequate assistance to lift and stabilize the module during installation or removal.

**Risk of damage to devices.** When placing a module into or removing the module from a rack:

- Extend the rack's leveling jacks to the floor.
- Ensure that the full weight of the rack rests on the leveling jacks.
- Install stabilizing feet on the rack.
- Extend only one rack component at a time.

### Poids du produit:

Chaque module de bibliothèque pèse 20kg sans média ni lecteur de bande, et 35kg avec média (40 cartouches) et trois lecteurs de bande. Lors du déplacement de la bibliothèque, pour réduire les risques de blessures ou de détérioration du périphérique:

- Respectez les règles locales de santé et de sécurité au travail ainsi que les instructions concernant la manipulation du matériel.
- Retirez les bandes des lecteurs avant de déplacer un module.
- Retirez toutes les bandes pour réduire le poids global du périphérique et pour empêcher les cartouches de tomber dans le chemin robotique et d'endommager la bibliothèque. Disposez les cartouches de sorte qu'elles réintègrent leur emplacement d'origine.
- Faites-vous assister pour soulever et stabiliser le périphérique pendant l'installation ou le retrait.

## Static Sensitive

Risk of Damage to Devices:

- A discharge of static electricity damages static-sensitive devices or micro circuitry.
- Proper packaging and grounding techniques are necessary precautions to prevent damage.

## Électricité statique

Risque d'endommager les périphériques par une décharge d'électrostatique:

- Une décharge d'électricité statique peut endommager les circuits imprimés du système ou les autres périphériques sensibles aux décharges électrostatiques.
- Un emballage approprié et une mise à la terre constituent les précautions nécessaires pour éviter tout dommage.

## Moisture



**CAUTION:** Do not expose the library to moisture. Do not place a module on either the module ends or sides as this may cause damage.

If the temperature in the room where the library operates varies by 15 °C (30 °F) or more from where the module was stored, allow it to acclimate for at least 12 hours prior to unpacking.

---

# Module Preparation

## Library Module Components

The following components are shipped in each module box:

- Base or Expansion Module
- Two Rack Rails
- Accessory Kit
  - One Rackmount Hardware Kit
  - One North American power cord
  - One European power cord
  - Expansion Interconnect Cable (Expansion Module only)

For SAS libraries, you must provide SAS cabling with the correct configuration for your HBA. For Fibre Channel libraries, you must provide one Fibre Channel cable for each tape drive.

## Preparing Top and Bottom Modules

Before unpacking any modules, clear a work surface near the targeted rack or table where the library is to be installed.

**NOTE:** Before opening and removing a module from the box, inspect the **container** for shipping damage. If you notice any damage, report it to the shipping company immediately.

1. Unpack the **module** from the box and place it on the work surface.

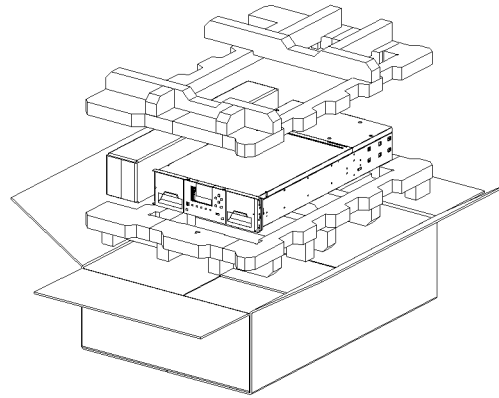

Save the packaging materials for future use.

2. For a **Base Module**, the robotics are protected during shipment by a foam insert which has to be removed prior to installation:
  - a. Remove the **top cover plate** from the Base Module by unlocking the top cover using two small screwdrivers.

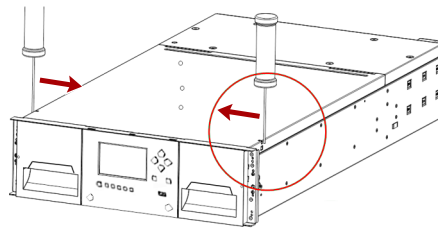

Push the screwdrivers down and inward in both slots.

- b. Lift the top cover **front edge** by about 4.75 in. (12cm) and pull the cover gently forward to disengage from the pivot point at the module center.

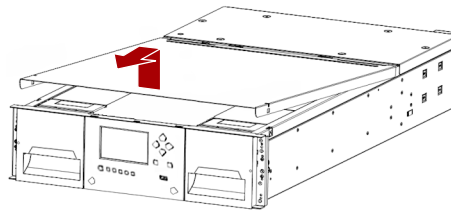

- c. Remove the **foam insert**.

3. If you are installing the Base Module by itself (without Expansion Modules) or as the top module of the library, reinstall the **top cover** on the Base Module.

With the front edge of the top cover raised about 4.75 in. (12cm), reengage the rear of the cover at the pivot point located at the back of the opening and lower the front of the top cover until the **latches engage** on both sides.

4. If you are installing one or more Expansion Modules **above** the Base Module, move the **top cover** from the Base Module to the top Expansion Module:
  - a. Place the **Expansion Module** on a work table.
  - b. With the front edge of the top cover raised about 4.75 in. (12cm), engage the **rear of the cover** at the Expansion Module pivot point.

- c. Lower the front of the top cover until the **latches engage** on both sides.
- 5. If you are installing one or more Expansion Modules **below** the Base Module, move the **bottom cover** from the Base Module to the bottom Expansion Module:
  - a. Place the **Base Module** on a work table.
  - b. Lift the unit **front end** by about 6 in. (16cm), using the unit rear as a pivot edge.
 

**NOTE:** The module needs to be supported while you remove the bottom cover.
  - c. Supporting the bottom cover with one hand, insert a small flat-head or Torx **screwdriver** into the hole and slide it about 1/4 in. (4mm) sideways to unlock the spring loaded lock.
  - d. Lower the cover front end by about 4 in. (10cm), pull gently forward to disengage from the pivot point at module center, and remove.

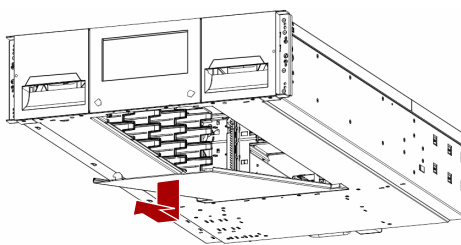

- e. Place the **Expansion Module** upside-down on a work table.
- f. With the front edge of the cover raised about 4 in. (10cm), insert the **rear of the cover** at the Expansion Module center point.
- g. Lower the **cover front edge** until you feel a hard stop and the cover locks in at the front of the module.

## Installing Modules in a Rack

NEOxl 40 Tape Library modules are easy to install in racks compliant to the EIA 310A Standard. You need a #2 Phillips screwdriver for this process.

### Install the Rack Rails

To locate the rail locations when installing multiple modules:

1. Determine the location in your rack for your module to be installed and, using a pencil, mark the **location** on each vertical rail in your rack.

It is recommended to start at the lowest position of the rack for stability. The bottom mark should be at the lowest narrow gap.

**NOTE:** The modules require 3U (5.25 in.) of rack space each.



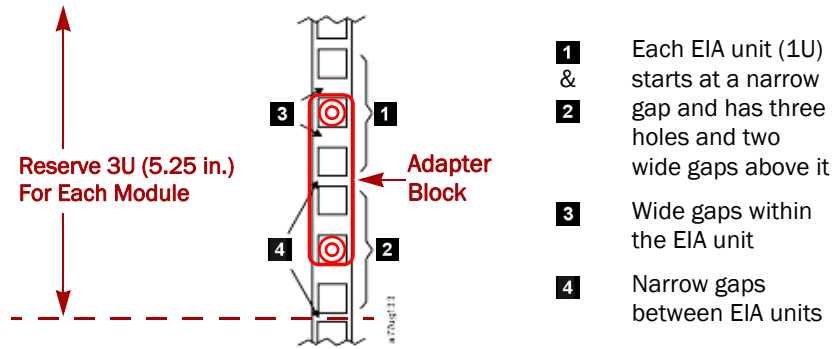

2. On the front of the rack, mount the left and right **adapter blocks** with the lower fixed nut in the middle hole of the bottom 1U space reserved for the module.

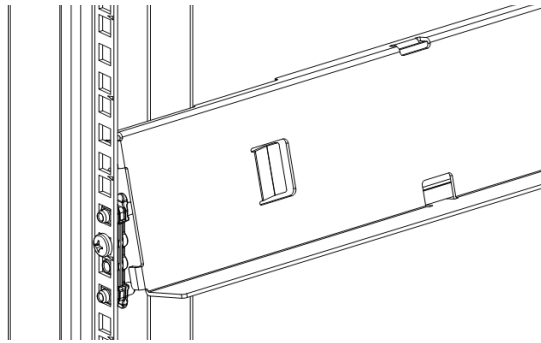

3. Secure the adapters with a **screw** through the front into one of the middle holes.
4. Mount the **rear adapters** making sure they are level with the front ones.
5. Mount the **LH Rackmount rail** to the left adapter blocks with the tray flange parallel to the floor and facing inward.

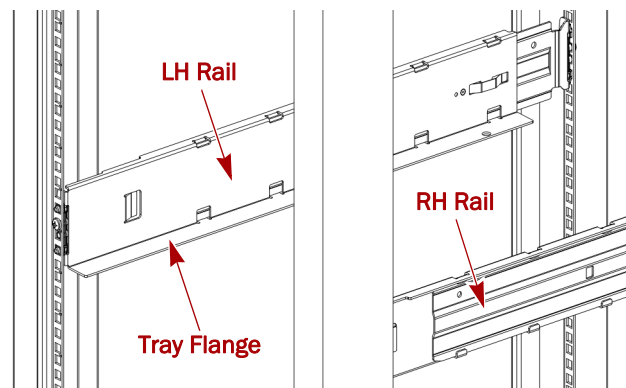

6. Mount the **RH Rackmount rail** to the right adapter blocks.

## Insert the Modules in the Rack

1. Using the mechanical lifter, position the **bottom module** in front of the rack, aligned with the rails in the lowest position.

- Slide the module onto the **rail flanges** and into the rack until it stops.

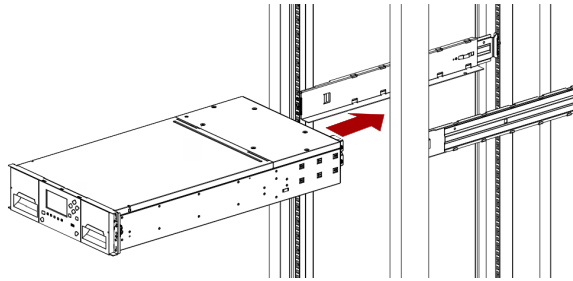

- Secure it to the rack with the **recessed Phillips screws** in the middle of the front flanges of the module to the adapter bracket's top fixed nut making them finger tight (do not over tighten).

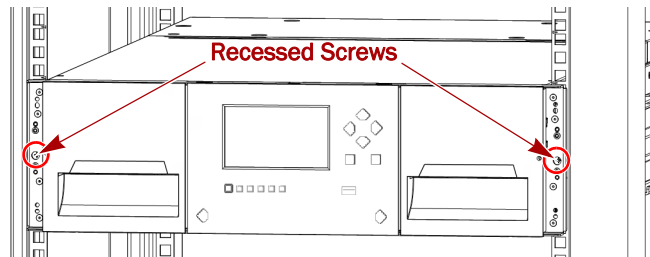

## Aligning and Connecting Modules

**NOTE:** Skip this step if the library does not have Expansion Modules.

Aligning the modules ensures that the robot can move freely between the modules. The library will not operate unless the alignment mechanism is in the locked position.

- At the front of the library, loosen the **screws** on each of the modules two full turns.
- At the back of the library, starting with the bottom pair of modules, **align each module** with the module below by moving the alignment lever of the upper module to the lock position. Repeat for each pair of modules.

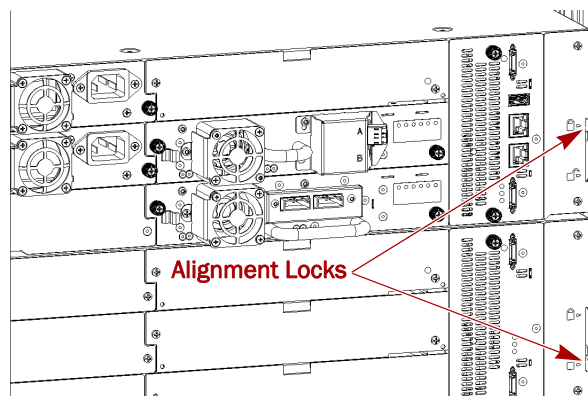

If you encounter resistance, adjust the upper module so that the alignment mechanism pin moves into the mating hole in the lower module.

- Verify that the **lowest module** in the library has its alignment mechanism in the unlocked position.

4. At the front of the library, tighten the **recessed Phillips screws** on all of the modules to secure the modules to the rack.
5. Connect the **expansion interconnect** cables from the module ports to any adjacent modules.

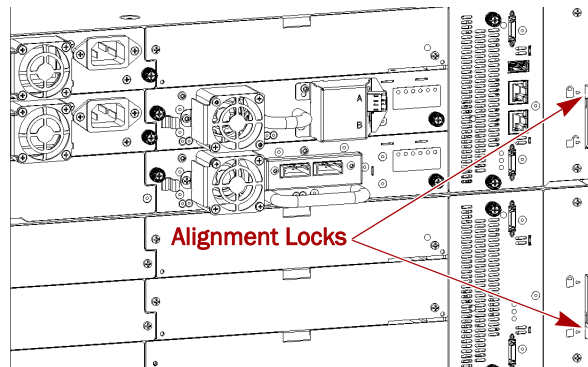

## Installing Tape Drives

---

**CAUTION:** It is recommended that you remove the power cables from the library and all attached accessories. Failure to remove the power cords from these devices before connecting the host interface cable could result in damage to the equipment.

---

**NOTE:** To assist in aligning the drive, only remove the drive bay covers for one drive at a time.

1. Locate an appropriate **vacant drive bay** at the rear of the library.  
Two drive bays are required for a full height drive.
2. Remove the **face plate** covering the drive bay by removing the screws holding it in place.
3. Holding the **tape drive** by the handle and supporting it from the bottom, slide the tape drive along the alignment rails into the drive bay until it is flush with the back of the library.
4. Finger-tighten the **blue captive screws** to secure the tape drive to the chassis.  
If the thumbscrews cannot be tightened, verify that the tape drive is aligned properly.

---

**WARNING:** Danger: Risk of hand pinching. Can trap hands, fingers and cause serious injury. Keep hands clear during operation. All drive bays without tape drives installed must have drive bay covers installed.

**AVERTISSEMENT:** Danger: Risque de se coincer la main et de se coincer les mains ainsi que les doigts le tout pouvant entrainer de graves blessures. Gardez les mains à l'écart pendant le fonctionnement.

---

## Connecting Fibre Channel Cables

1. If necessary, remove the **FC port caps** on the tape drive.
2. Attach one end of the **host interface cable** to the Port A (top) connector on the FC drive.

FC Tape Drive

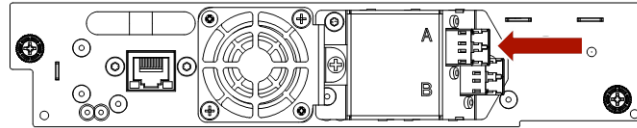

3. Attach the **other end** of the host interface cable to the host or to a switch.

## Connecting SAS Cables

**NOTE:** SAS signal rates require clean connections between the HBA and tape drive. Do not use adapters or converters between the HBA and the tape drive. For reliable operation, use a maximum SAS cable length of six meters.

1. Attach one end of the **SAS host interface cable** to Port A SAS HBA (top) on the SAS tape drive.

If you are using a SAS fanout/hydra cable, attach one mini-SAS connector into the connector on each tape drive. The unused ends of the SAS fanout cable are single channel and not suitable for use with disk arrays. Use the other ends to connect tape drives, or coil and secure them to the rack to minimize stress on the connectors.

SAS Tape Drive

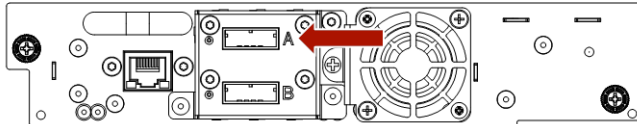

2. Attach the **other end** of the SAS host interface cable to the host HBA, using a direct SFF-8088 connection. Unused SAS connectors do not need termination.

If you are using a SAS fanout/hydra cable, the end of the cable with only one connector should be plugged into the HBA.

## Final Connections

1. To enable access to the RMI, plug the **network Ethernet (management) cable** into the Ethernet port (1) on the rear panel of the Base Module.

**NOTE:** If the Ethernet connection is directly attached to a server or laptop, a crossover Ethernet cable may be required. It is the customer's responsibility to supply the crossover cable if one is required.

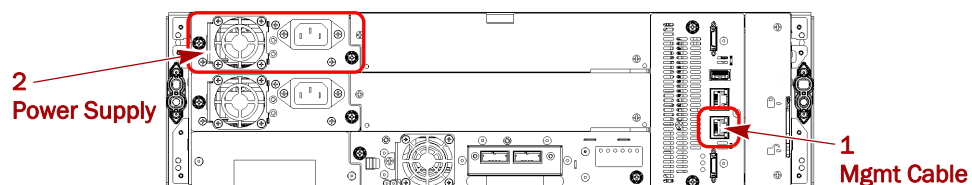

2. Plug the **power cable** into the power connector (2) on the power supply modules and into power outlets.  
If the optional second power supply has been installed to increase the redundancy, plug each power cord into a different AC power circuit.
3. If any Expansion Modules have power supplies installed, plug each **power cable** into the power connector (2) on the power supply modules and into different AC power outlets than the other modules.

Continue with [Chapter 3, "Initial Setup."](#)

# 3

## Initial Setup

Once all the NEOxl 40 Tape Library hardware is installed and connected, the first step is to start configure the library:

- Power on the library.
- Resolve the network IP address.
- Run the Initial Configuration Wizard from the OCP. The wizard guides you through configuring:
  - The administrator PIN.
  - Timezone, date, and time settings.
  - Basic network configuration.

You can skip wizard items and stop the wizard at any time. When done, an initial system test begins.

### Topics in Initial Setup:

- [Powering On the Library](#)
- [Initial Setup Using the OCP Wizard](#)
- [Complete Setup Using the RMI](#)
- [Verifying the Host Connection](#)
- [Loading Tape Cartridges](#)
- [Verifying the Installation](#)
- [Configuring Additional Features](#)

## Powering On the Library

Power on the library from the Base Module front panel by pressing and holding down the power button for three (3) seconds. The green light on the front panel illuminates indicating the status is **Ready**.

When the library is powered on, it inventories the tape cartridges in the magazines, checks the firmware version on all modules, configures the tape drives, searches for any new modules, and checks the network.

At this first time power on, it displays a message on the OCP display that the network IP is incorrect. Use the OCP to update the IP address:

**NOTE:** For complete details, refer to Chapter 5, “Operator Control Panel.”

1. Using the navigation buttons, go to the OCP **Configuration > Network Settings** screen.
2. Configure the following as needed:
  - Host Name

- Domain Name
  - Protocol
  - IPv4 or IPv6 related settings
3. Press **Down** to navigate to **Submit**.
  4. Press **Enter**.  
The tape library will automatically reboot.

## Initial Setup Using the OCP Wizard

Once you have configured the network settings and the tape library has rebooted, the user is prompted to walk through the Initial Configuration wizard.

**NOTE:** It is recommended to walk completely through the wizard and finish it by pressing the **Finish Button**. Otherwise, with every login on the OCP, the user is prompted to walk through the wizard again.

## Complete Setup Using the RMI

Once you have configured the basic settings with the OCP Initial Configuration wizard, you can initiate the partition wizard from the RMI.

1. To log into the **RMI**, use the default User name “**administrator**” and Administrator Password “**adm001**”.
2. On the Home page, click **Configuration**.
3. In the right pane, click **Partitions**.
4. Click **Basic Wizard**.  
The wizard displays the configured partitions. However, when the library is first powered on and before partitions are configured, this list will be empty.
5. In the Information page, click **Proceed** and then click **Next**.  
The wizard displays default partition settings with all available resources configured as part of a single partition.
6. Click **Next** to accept the defaults.
7. At the Finish Configuration page, click **Finish**.  
To make changes at a later time, you can use either of the partition wizards.

## Verifying the Host Connection

To verify the connections between the host computer and the library:

1. Install the **application software and/or drivers** that are compatible with the library.  
Backup software packages might require additional software or licensing to communicate with the robotics.
2. Verify the connection between the library and the host using the host server’s **operating system utilities**.

## Loading Tape Cartridges

The library can be powered on without cartridges, but needs to have cartridges installed before performing either data read/write operations, or any tests or operations that transfer cartridges.

The easiest way to open either the mailslot or entire magazine is to use the magazine unlock buttons on the front panel. The LED in the translucent button indicates different states of the mailslot or magazine:

- **LED steady ON** – Mailslot is enabled.
- **LED flashing slowly** – Unlock operation is in process.
- **LED flashing quickly** – Mailslot or magazine is unlocked and can be removed.
- **LED OFF** – Magazine/Mailslot is locked.

The mailslot must be enabled before it can be opened. To enable a mailslot, see [Mailslot Configuration on page 88](#).

Example: A three-module library with mailslots enabled and unlocked only on the top two modules:

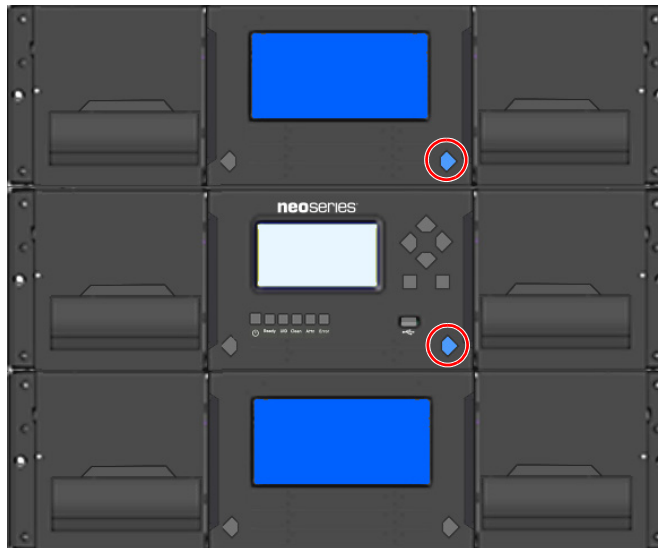

**NOTE:** You can also open mailslots or magazines through the RMI using either the **Operation > Open Mailslot** or **Operation > Open Magazine**. Opening mailslots or magazines through the OCP is not possible.

## Labeling Tape Cartridges

Barcode labels are recommended in production environments to improve inventory time in the library and ease cartridge handling processes outside the library.

## Using the Mailslot to Load Tape Cartridges

If the mailslot is enabled (indicated by the right button LED steady ON), you can use it to load cartridges into the library.

1. Press the **right button** for less than three seconds.

This starts the unlock operation for the mailslot indicated by the LED slowly flashing.



2. When the mailslot is unlocked, the **LED** starts quickly flashing.
3. Pull the **mailslot** out of the library until it stops.

**NOTE:** The mailslot is attached to the magazine and cannot be removed completely. If not opened, the mailslot relocks after 30 seconds.

As soon as the mailslot is pulled out, the LED switches OFF.

 **IMPORTANT:** You can enable mailslots only through the **Configuration > Mailslots** page on RMI. Enabling the mailslots through the OCP is not possible. Wait before pulling out the mailslot until the LED is quickly flashing and OCP message says that the mailslot is unlocked.

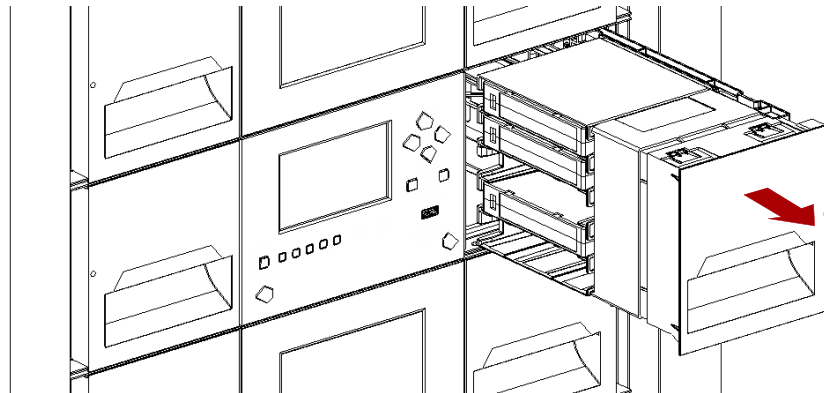

## Bulk Loading Magazines

1. From the OCP or RMI, select the module **magazine** for loading and then select **Open Magazine**.
2. Using the magazine **access handle** and supporting it underneath, pull the magazine out of the library.

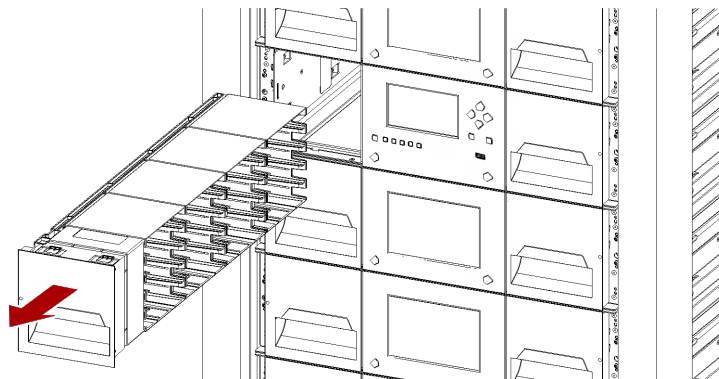

3. Load the **tape cartridges** into the magazine starting at the rear.
4. When done, insert the **magazine** back into the magazine bay supporting it underneath.
5. Slowly push the magazine in by its **handle** until the release latch snaps back into place, locking the magazine.
6. Repeat [Steps 1–5](#) for any **other magazines** until all the cartridges are loaded.

## Verifying the Installation

Verify that the library has the **current firmware** revision.

The library firmware revision is displayed in the top left corner of the RMI Home page or on the OCP **Home > Status > Library > Library Status** screen.

If necessary, update the library firmware. You can update firmware from the RMI (**Maintenance > Firmware Upgrades > System Firmware**) or the OCP (**Maintenance > Library Firmware Upgrade**).

After configuring the library, you can save the configuration settings to a USB flash drive from the OCP or to a file on your computer from the RMI **Configuration > Save/Restore** page. Having a backup of the library configuration is helpful when recovering from a configuration error or if the library needs service. See [Chapter 6, "Save/Restore Library Configuration."](#)

## Configuring Additional Features

Additional features can be set up at this time using the OCP.

### Enabling and Configuring SNMP Network Management

See [SNMP Configuration on page 84 in Chapter 6, "Remote Management Interface."](#)

### Email Event Notification

See [SMTP Configuration on page 85 in Chapter 6, "Remote Management Interface."](#)

### Modifying the Default Tape Drive Settings

**NOTE:** When connecting an LTO-7 or later FC tape drive directly to the host, configure the FC port in Loop mode.

See [Tape Drive Configuration on page 87 in Chapter 6, "Remote Management Interface."](#)

### Enabling the Mailslot

See [Mailslot Configuration on page 88 in Chapter 6, "Remote Management Interface."](#)

### Configuring Partitioning

- **Basic Partition Wizard** – Use the Basic Partition Wizard to configure partitions that will have similar resources or to configure the number of bar code characters to report to the host application and whether to report them from the left or right end of the label for a library with a single partition.
- **Expert Partition Wizard** – Use the Expert Partition Wizard to configure partitions that will have different resources or to adjust resource assignments for existing partitions or those partitions created with the Basic Partition Wizard.

See [Partition Configuration on page 88 in Chapter 6, "Remote Management Interface."](#)

# 4

## Basic Library Operation

This chapter covers the basic functions used to operate your NEOxl 40 Tape Library.

The library has two interfaces:

- **Operator Control Panel (OCP)** — Monitor, configure, and control the library from the Base Module’s front panel.
- **Remote Management Interface (RMI)** — Monitor, configure, and control the library remotely with a web browser. The RMI hosts a dedicated, protected internet site that includes a graphical representation of the library.

### Topics in Basic Library Operation:

- [User Levels](#)
- [OCP Library Operation](#)
- [RMI Library Operations](#)
- [Manual Tape Magazine Access](#)

## User Levels

The user levels available in both the OCP and the RMI are:

- **User** – No password is required (leave the **Password** blank unless the user password has been set at **Configuration > User Accounts**).  
The user account provides access to status information, but not the configuration, maintenance, or operation functions.
- **Administrator** – The administrator password is required to login as the administrator. The default administrator password is “**adm001**” for the first login. The administrator password can then be changed at **Configuration > User Accounts**.  
The administrator user has access to all functionality except the log configuration, Security access, and Service access.
- **Security** – The default security password is set at the factory to “**sec001**”. The security password can be changed at **Configuration > User Accounts**.  
The security user has access to all functionality except the log configuration and Service access. When KMIP is enabled, security access is required to configure the encryption.
- **Service – Access to the Service user is by Service personnel only.** The service password is set at the factory. Both the administrator and service passwords are required for a service person to enter the Service area.

# OCP Library Operation

The Base Module front OCP panel has an LCD display, five navigation buttons plus an Enter button to the right of the display, a power button, five LEDs plus USB port below the display, and two magazine buttons at the bottom. With the OCP you can monitor, configure, and operate most library functions from the library front panel.



OCP Panel

To navigate the OCP, use the five navigation buttons (Up, Down, Left, Right, and Back) and the Enter button.



There are five LED indicators to the right of the Power button.

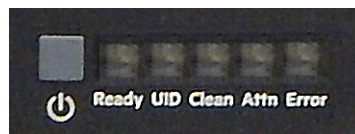

LED	Color	Description
Ready	Green steady	Library power is ON.
	Green flashing	Blinking when there is tape drive or library robotic activity.
UID	Blue	The Unit Identification (UID) LEDs are controlled by the user through the action <b>Turn Identifier Light On or Off</b> on the Dashboard page of the RMI. The UIDs on the OCP and base module back panel are activated and deactivated together. In addition, UIDs on drives and expansion module back panels can be activated separately. The UIDs are helpful for locating components of the library in a data center.
Clean	Amber	A tape drive cleaning operation is recommended.
Attn	Amber blinking	The library has detected a condition for which user attention is necessary, but that the library can still perform most operations.
Error	Amber	An unrecoverable tape drive or library error occurs. A corresponding error message is displayed on the OCP screen. User intervention is required; the library is not capable of performing some operations.

## OCP Home Screen

The OCP Home screen consists of three areas:

neo series	<b>Operation</b>
<b>FW</b> 1.0.0-0001	Configuration
<b>Modules</b> 2	Maintenance
<b>Slots</b> 13/72	Status
<b>Drv</b> 3	Logout
<b>Err</b> 0	
<b>Warn</b> 1	
<b>Time/Date:</b> 07:25:37 08.12.2017	

- **Left Pane** – Displays the library status (firmware revision [**FW**], number of modules [**Modules**], number of slots [**Slots**], number of drives [**Drv**], number of errors [**Err**], and number of warnings [**Warn**]).
- **Right Pane** – Provides access to operate and configure the library and to view additional status information (**Operation**, **Configuration**, **Maintenance**, **Status**, and **Logout**)
- **Bottom Pane** – Displays additional status information (library status, time/date, or IPv4/IPv6 address). The status pane displays one status information for ten seconds and then switches to the next status item.

## OCP Menu

The OCP provides a subset of menu items compared to the full capability of the RMI. Menu items that are similar to ones in the RMI are not covered in this section. Refer to [RMI Library Operations on page 46](#) for details.

- Initial Setup
- Operation
  - Move Media
  - Move Cartridge from Drive to Home Slot
  - Inventory Scan
  - UID LED Control
- Configuration
  - Date & Time
  - Network Settings
  - Drive Power On/Off
  - User Accounts
    - Change PIN
    - Restricted RMI Login
  - Save/Restore
    - Save Configuration File
    - Restore Configuration File
    - Reset Default Settings
    - Reset List of Known Drives and Modules
    - Reset Default Manufacturing Settings
- Maintenance

- Library Tests
  - System Test
  - Slot to Slot Test
  - Robotic Test
  - OCP Test
  - Wellness Test
- View Event Ticket Logs
- Drive Support Ticket Download
- Library Support Ticket Download
- Library Logs Download
- Drive Firmware Upgrade
- Library Firmware Upgrade
- Move Robotic to Base Module
- System Reboot
- LCD Adjustment
- SSH (Secure Shell)
- Open Magazines/Mailslots
- Status
  - Network Settings
  - Library
  - Drive
- About
- Logout

## Log Into The Library (OCP)

To log in to the library on the front panel OCP:

1. If the OCP screen saver is on, press **Enter** to display the **Login** screen.
2. From the drop-down list, select the **User**.

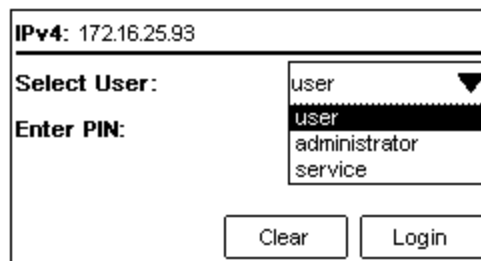

The screenshot shows a login interface on a device. At the top, it displays 'IPv4: 172.16.25.93'. Below this, there are two labels: 'Select User:' and 'Enter PIN:'. To the right of 'Select User:' is a drop-down menu with a downward arrow. The menu is open, showing four options: 'user', 'user', 'administrator', and 'service'. The first 'user' option is highlighted with a black background. At the bottom of the screen, there are two buttons: 'Clear' and 'Login'.

3. If required, enter the **PIN**.



4. Select the **Login** button and press **Enter** on the front panel.  
Press **Clear** to cancel the login.

For details regarding the OCP menu options, see [Chapter 5, “Operator Control Panel.”](#)

## RMI Library Operations

When possible, it is recommended that the RMI be used as the primary library interface because the web interface provides access to additional features, includes online help, and is easier to use. However, the RMI is not required to use the product, except to configure advanced features, such as SNMP, IPv6, encryption, and partitions.

Before using the RMI, you must configure the library network settings with the OCP. This can be done with the Initial Configuration Wizard. See [Initial Setup Using the OCP Wizard on page 38](#).

To start the RMI, open the latest version of a supported HTML browser and enter the IP address of the library in the browser’s address bar. Supported browsers include Internet Explorer, Firefox, Chrome, and Safari.

**Tip:** Check the online help in the RMI for additional information. The help pages are updated with firmware updates and often contain up-to-date technical details that might not be contained in this document. To access RMI online help, click the “?” icon on the right side of the RMI top banner.

The RMI main page is organized into the following regions:

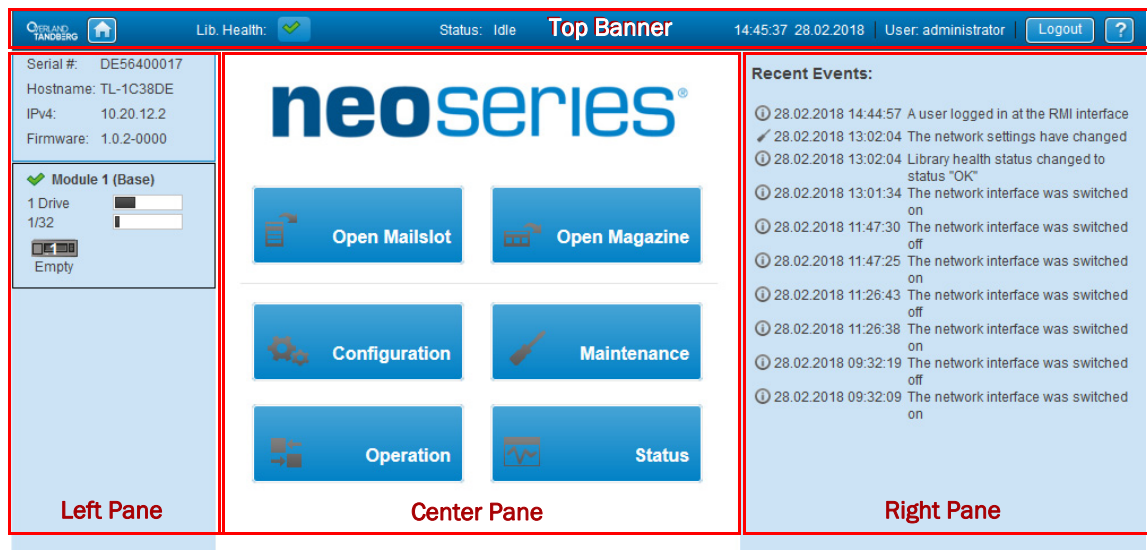

- **Top Banner** – Contains the Home button and displays the overall status and information about the library and user.
- **Left Pane** – Displays the library identity and module status.
- **Center Pane** – Provides access to operate and configure the library and to view additional status information.
- **Right Pane** – Displays a log of recent events at root level or additional functions when **Configuration**, **Maintenance**, **Operation**, or **Status** is selected.

## Log Into The Library (RMI)

To log in remotely to the library using the RMI:

1. Open a supported web browser and enter the **IP address** of the library in the browser's address bar.
2. From the drop-down list, select the **User**.

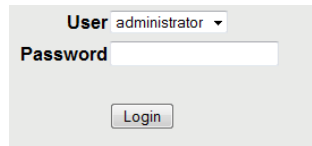

3. If required, enter the **Password**.
4. Click **Login**.

For details regarding the RMI menu options, see [Chapter 6, “Remote Management Interface.”](#)

## Manual Tape Magazine Access

The tape magazines and mailslots can be manually accessed from the front panel of the NEOxl 40 Tape Library. Each tape magazine has a button located at the lower corners of the center panel that unlocks the magazine. There is an LED in the button that also provides a status for the magazine.



Each right magazine can be configured to have the front portion designated as an mailslot. To unlock the mailslot, press the right magazine button for less than three seconds.

To unlock an entire right or left magazine, press the magazine button for more than three seconds. The magazine is pulled out manually once it is unlocked. After a magazine has been opened and closed, a library inventory is automatically performed.



The button LED provides an indicator of the current state of that magazine as shown in the following table:

Magazine State	LED State	Description
Closed	Steady ON	Mailslot is enabled.
Closed	Slow Flash	Magazine unlock is in progress.
Closed	Fast Flash	Magazine is unlocked.
Closed	OFF	Mailslot is not enabled.
Opened	OFF	Magazine is opened.

**NOTE:** If an magazine unlock is in process, no other magazines or mailslots can be unlocked. If an unlocked magazine is not opened within 30 seconds, the magazine is relocked.

# 5

## Operator Control Panel

The Operator Control Panel (OCP) refers to the front panel of the Base Module and consists of an LCD display, navigation buttons, operation buttons, LEDs, and a USB port. With the OCP, you can monitor, configure, and operate most library functions.



OCP Panel

To navigate the OCP display, use the five navigation buttons (Up, Down, Left, Right, and Back) and the Enter button.



The OCP Home screen has five menu categories that are covered in detail in this chapter.

neo series	Operation
FW 1.0.0-0001	Configuration
Modules 2	Maintenance
Slots 13/72	Status
Dry 3	Logout
Err 0	
Warn 1	
Time/Date: 07:25:37 08.12.2017	

The OCP screen provides just a subset of menu items as compared to the full capability of the RMI. Menu items that are similar to the RMI menu items are not described in detail in this chapter. For those items, refer to the corresponding [Chapter 6, “Remote Management Interface.”](#)

**Topics in Operator Control Panel:**

- [Change Settings Procedure](#)
- [Operation Menu](#)
- [Configuration Menu](#)
- [Maintenance Menu](#)
- [Status Menu](#)
- [Logout](#)

## Change Settings Procedure

The navigation and Enter buttons on the Base Module front panel are used to make changes in the OCP screen menus.

1. To make changes, used the navigation buttons to select an **option** displayed on the OCP screen.  
A bold box shows around the selected option.
2. Press **Enter** to select the option.
  - **Text Options** – An underscore (\_) appears under the first character (or space).
  - **List Options** – A drop-down list is shown for a list specific selections.
3. Create or change the **setting**.
  - **Text Options** – Use **Left/Right** to select a text character and **Up/Down** to choose the replacement character (a-z, A-Z, 0-9, period [.] or hyphen [-]). Use **Up** to go forward in the list and **Down** to go back. Press and hold **Up/Down** to skip four characters at a time.
  - **List Options** – Use **Up/Down** to choose an item from the list.
4. Press **Enter** to accept the change and return to the selection process.  
To cancel a change, navigate to the end of the options and select Cancel.

## Operation Menu

Use the navigation buttons to select the **Operation** menu on the Home screen.

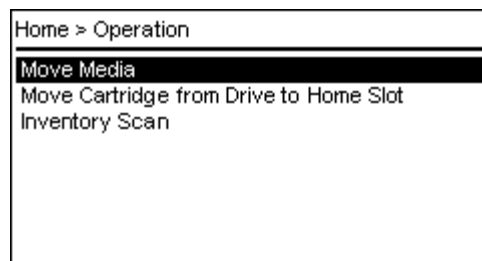

The Operation Menu provides the following submenus:

- [Move Media](#)
- [Move Cartridge from Drive to Home Slot](#)
- [Inventory Scan](#)

## Move Media

With the **Operation > Move Media** feature, the user can move a cartridge within the library (for example, to a mailslot or drive).

1. At the Move Media instruction screen, press **Enter** to open the **Source** selection screen.

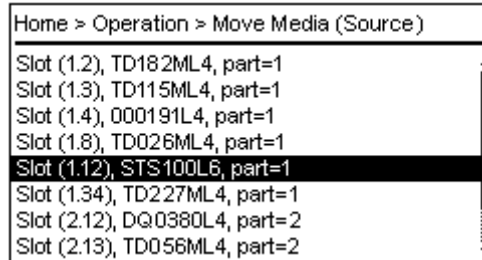

A list of cartridge locations is shown. Pressing the **Back** button returns you to the Operation menu. Use the navigation buttons to select the source.

2. With the source selected, press the **Enter** button to open the **Destination** selection screen.

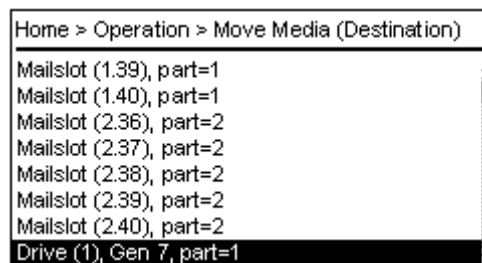

A list of possible destinations is shown. Pressing the **Back** button returns you to the Operation menu. Use the navigation buttons to select the destination.

3. With the destination selected, press the **Enter** button to view the summary screen.

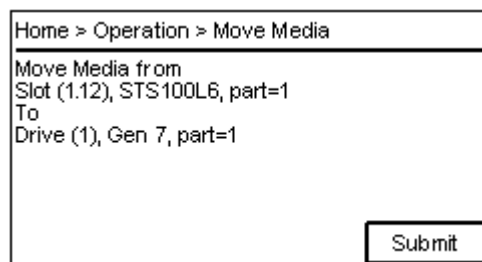

Because **Submit** is already selected, just press the **Enter** button to start the Move Media operation. Pressing the **Back** button aborts the procedure and returns you to the Operation menu. There you can step through the screens again to change the selections.

When the Move command finishes, the screen switches back to the Home screen.

## Move Cartridge from Drive to Home Slot

With the **Operation > Move Cartridge from Drive to Home Slot** feature, the user can move a cartridge from a drive back to its home slot.

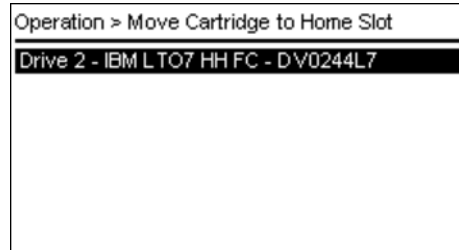

The **Operation > Move Cartridge from Drive to Home Slot** screen displays all drives that contain cartridges.

1. Use the navigation buttons to select the **drive** from which you want to return the cartridge to its home slot.
2. Press **Enter**.

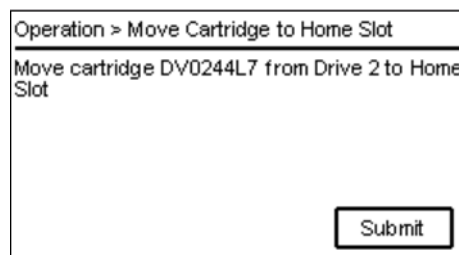

3. With **Submit** selected, press **Enter** to activate the Move command.

## Inventory Scan

The **Operation > Inventory Scan** feature manually scan the library inventory.

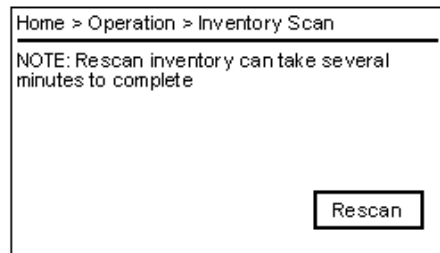

Because Rescan is already selected, just press the Enter button to start the inventory scan process.

## Configuration Menu

Use the navigation buttons to select the **Configuration** menu on the Home screen.

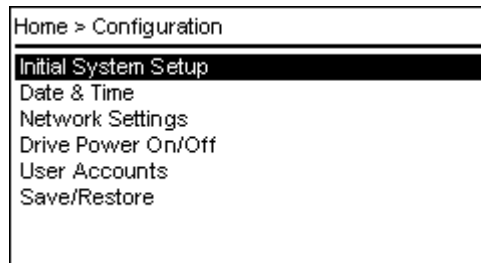

The Configuration Menu provides the following submenus:

- [Initial System Setup](#)
- [Date and Time Configuration](#)
- [Network Settings](#)
- [Drive Power On/Off](#)
- [User Accounts](#)
- [Save/Restore](#)

### Initial System Setup

For initial configuration of your NEOxl 40 Tape Library, navigate to the **Configuration > Initial System Setup** screen.

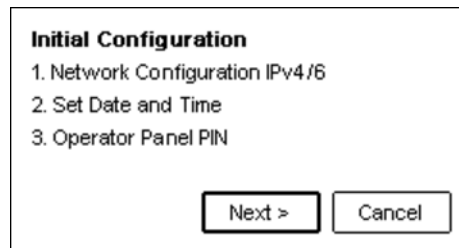

The Initial Configuration wizard guides you through setting up the library network configuration, configuring the date and time, and setting the administrator PIN. You can skip items and stop the wizard at any time. When you have configured the network settings, you can initiate the wizard from the RMI to complete the remaining configurations.

**NOTE:** On the very first power up of the library, the user is prompted to run the Initial Configuration wizard. It is recommended to go completely through the wizard and finish the initial configuration by choosing **Finish**. Otherwise, with every login on the OCP screen, the user is prompted again to go through the wizard.

Once the network settings have been configured, you can initiate the wizard from the RMI to complete the remaining settings. To login the very first time on the RMI, use the default User name "**administrator**" and administrator password "**adm001**".

1. At the **Initial System Setup** screen, select **Next >** and press **Enter** to start the wizard with network configuration.

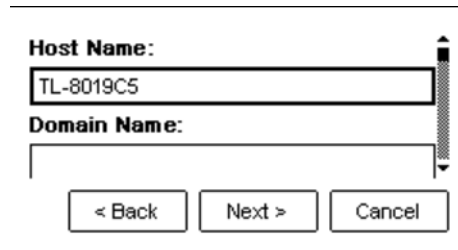

The screenshot shows a window titled "Initial System Setup" with two text input fields. The first field is labeled "Host Name:" and contains the text "TL-8019C5". The second field is labeled "Domain Name:" and is currently empty. Below the fields are three buttons: "< Back", "Next >", and "Cancel".

Under network configuration, you can configure these items using the navigation buttons:

- Host Name
  - Domain Name
  - Protocol
  - IPv4 related settings:
    - Method
    - IPv4 Address
    - Netmask
    - IPv4 Gateway
    - IPv4 DNS1
    - IPv4 DNS2
  - IPv6 related settings:
    - Method
    - IPv6 Address
    - IPv6 Gateway
    - Prefix Length
    - IPv6 DNS1
    - IPv6 DNS2
2. Make changes to the **network settings**. (See
  3. When finished with the network settings, select **Next >** and press **Enter** to continue with Date/Time Configuration.

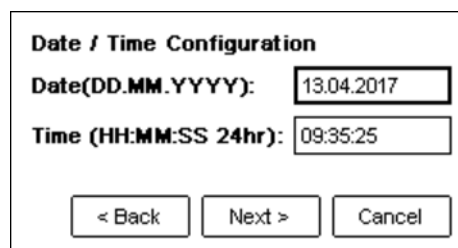

The screenshot shows a window titled "Date / Time Configuration" with two text input fields. The first field is labeled "Date(DD.MM.YYYY):" and contains the text "13.04.2017". The second field is labeled "Time (HH:MM:SS 24hr):" and contains the text "09:35:25". Below the fields are three buttons: "< Back", "Next >", and "Cancel".

4. When finished with the date and time settings, select **Next >** and press **Enter** to continue with the **Operator Panel PIN** setting.

5. When finished with the PIN change, select **Next >** and press **Enter** to switch to the **Finish** screen.

6. To keep the settings, select the **Finish** option and press **Enter**.  
Press **Cancel** to skip the configuration and leave the wizard without any changes. Press **< Back** to correct your changes before they are submitted.

## Date and Time Configuration

To configure the date and time, navigate to the **Configuration > Date/Time** screen.

1. With the **Date** field selected on the Date/Time screen, press **Enter** to change the date starting with the day:
  - a. Use **Up/Down** to chose the day.
  - b. Press **Right** to move to the month.
  - c. Use **Up/Down** to chose the month.
  - d. Press **Right** to move to the year.
  - e. Use **Up/Down** to chose the year.
  - f. Press **Enter** to save the changes.
2. Press **Down** to navigate to the **Time** field.
3. Press **Enter** to change the time starting with the hour:
  - a. Use **Up/Down** to chose the hour.



- b. Press **Right** to move to the minute.
  - c. Use **Up/Down** to chose the minute.
  - d. Press **Right** to move to the second.
  - e. Use **Up/Down** to chose the second.
  - f. Press **Enter** to save the changes.
4. Press **Down** to navigate to **Submit**.
  5. Press **Enter** to submit the new date and time.

## Network Settings

To configure the network settings, go to the **Configuration > Network Settings** screen. The following settings can be changed:

- Host Name
- Domain Name
- Protocol
- IPv4 related settings:
  - Method
  - IPv4 Address
  - Netmask
  - IPv4 Gateway
  - IPv4 DNS1
  - IPv4 DNS2
- IPv6 related settings:
  - Method
  - IPv6 Address
  - IPv6 Gateway
  - Prefix Length
  - IPv6 DNS1
  - IPv6 DNS2

## Drive Power On/Off

From the **Configuration > Drive Power On/Off** screen, a drive's power on or off.

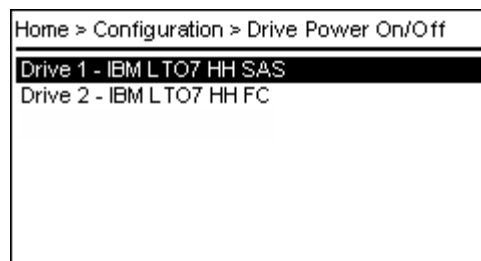

1. From the list of all installed drives, select the **drive** for which you want to change the drive power status.
2. Press **Enter**.

- At the details screen for the selected drive (the power status is the default selection), press **Enter**.

Drive Power On/Off > Drive 1	
<b>Power:</b> On	<input type="button" value="Power Off"/>
<b>Drive Num:</b>	1
<b>S/N:</b>	000000005C
<b>Vendor:</b>	HP
<b>Type:</b>	LTO7 HH FC
<b>Cartridge:</b>	Empty

- At the confirmation message, select **Yes** and press **Enter**.

## User Accounts

The **Configuration > User Accounts** screen provides the following submenus:

- [Change PIN](#)
- [Restricted RMI Login](#)

### Change PIN

From the **Configuration > User Accounts > Change PIN** screen you can change the PINs used to access the OCP screen.

User Accounts > Change PIN	
<b>Select User:</b>	<input type="text" value="administrator"/> ▼
<b>Enter PIN:</b>	<input type="text" value="****"/>
<b>Repeat PIN:</b>	<input type="text" value="****"/>
	<input type="button" value="Submit"/>

- Navigate to the **Select User** drop-down box and select a **User** from the list.
- Navigate to the **Enter PIN** field and press **Enter**.
- Using the **Change Settings Procedure**, change the PIN.
- Press **Enter** to accept the change.
- Navigate to the **Repeat PIN** field and press **Enter**.
- Using the **Change Settings Procedure**, change the PIN.
- Press **Enter** to accept the change.
- With **Submit** activated, press **Enter** to submit the new PIN.
- If "0000" is selected as the PIN (causing the user to be automatically logged into the system), a confirmation message is shown; select **Yes** and press **Enter**.

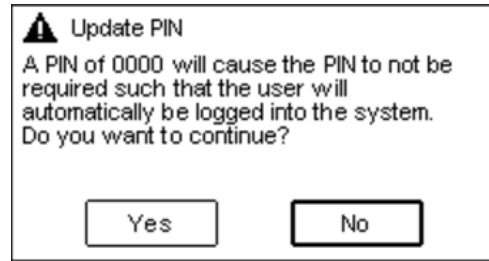

A PIN update confirmation message is shown.

**NOTE:** As long as you stay logged in, the new PIN will not become active. Only after you log out will the new PIN become valid.

### Restricted RMI Login

From the OCP **Configuration > User Accounts > Restricted RMI Login** screen, you can restrict access to RMI web interface.

If the **Restricted RMI Login** is enabled, the administrator and Security is not able to login via RMI anymore. The administrator has to disable the restriction via OCP.

After selecting the **Restricted RMI Login** option, the screen below is shown:

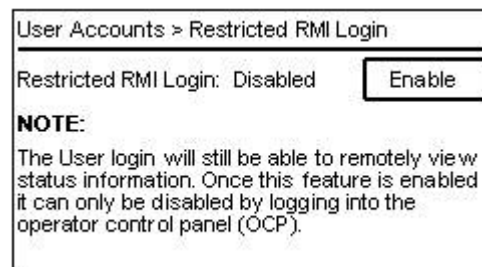

Press **Enter** to enable the **Restricted RMI Login** option. The following screen is shown to inform the user that the restricted mode is enabled.

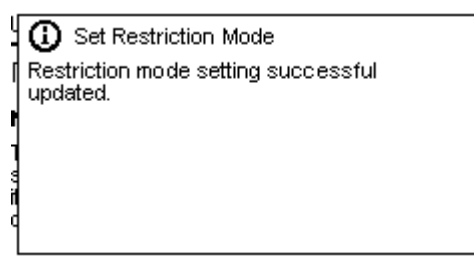

### Save/Restore

The **Configuration > Save/Restore** screen provides the following submenus:

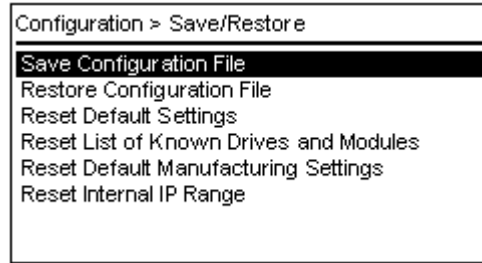

- [Save Library Configuration File](#)
- [Restore Library Configuration File](#)
- [Reset Default Settings](#)
- [Reset the List of Known Drives and Modules](#)
- [Reset Default Manufacturing Settings \(only accessible with Service PIN\)](#)
- [Reset Internal IP Range](#)

### Save Library Configuration File

From the **Save/Restore > Save Configuration File** screen, you can save the library configuration on a USB device.

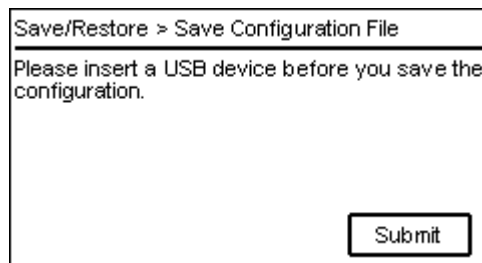

1. Insert a **USB device** in the OCP USB port.
2. To save the configuration file on the USB device, with **Submit** selected, press **Enter**.  
A dialog notifies you that the saving process has started. This can take a few minutes.
3. At the successfully saved message (with **Close** selected), press **Enter**.

You are returned to the save the configuration file message. Press **Back** as needed to exit.

### Restore Library Configuration File

From the **Save/Restore > Restore Configuration File** screen, you can restore the library configuration from a USB device.

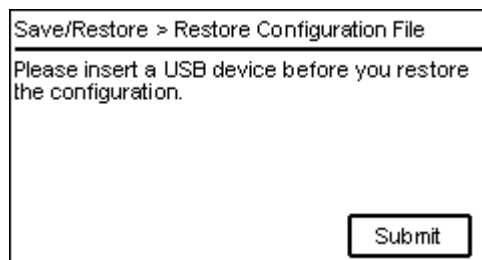

1. Insert a **USB device** that contains a saved configuration in the OCP USB port.

2. To restore the configuration file from the USB device, with **Submit** selected, press **Enter**.
3. At the confirmation message, select **Yes** and press **Enter** to start the restore.  
A dialog notifies you that the restore process has started. This can take a few minutes.
4. At the successfully saved message (with **Close** selected), press **Enter**.

You are returned to the restore the configuration file message. Press **Back** as needed to exit.

### Reset Default Settings

From the **Save/Restore > Reset Default Settings** screen, you can reset the library to the default configuration settings.

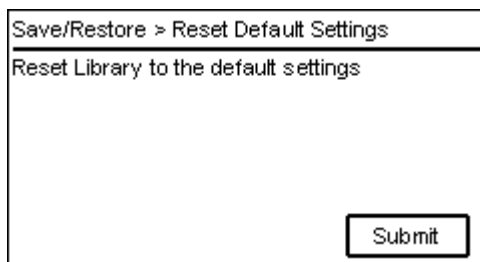

1. To reset the configuration settings to default, with **Submit** selected, press **Enter**.  
A dialog prompts you to confirm the reset process.

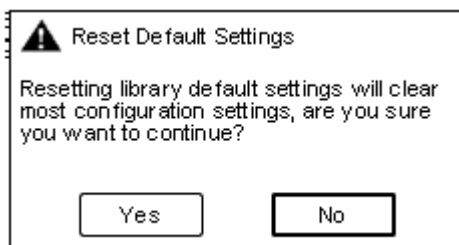

2. Select **Yes** and press **Enter** to start the reset.
3. At the successfully reset message, the **library** automatically reboots.

### Reset the List of Known Drives and Modules

The **Save/Restore > Reset List of Known Drives and Modules** screen enables you to remove missing Modules and Drives from the library stack list.

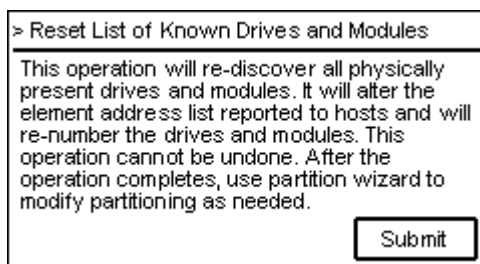

1. To reset the list of drives and modules in the library, with **Submit** selected, press **Enter**. A dialog prompts you to confirm the list reset process.
2. At the confirmation message, select **Yes** and press **Enter** to reset.
3. At the successfully reset message (with **Close** selected), press **Enter**.

### Reset Default Manufacturing Settings (only accessible with Service PIN)

After logging on as Service, use this option to return to the default manufacturing settings.

### Reset Internal IP Range

Internal IP address range is configured during initial library setup wizard (refer to [Internal IP Range Selection](#)). Use this configuration option if you need to reset the internal IP address range at a future time because of changes to the customer network.

## Maintenance Menu

Use the navigation buttons to select the **Maintenance** menu on the Home screen.

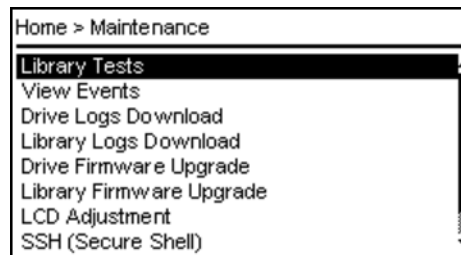

The Maintenance Menu provides the following submenus:

- [Library Tests](#)
- [View Events](#)
- [Drive Logs Download](#)
- [Library Logs Download](#)
- [Drive Firmware Upgrade](#)
- [Library Firmware Upgrade](#)
- [LCD Adjustment](#)
- [SSH \(Secure Shell\)](#)

### Library Tests

The **Maintenance > Library Tests** screen provides the following submenus:

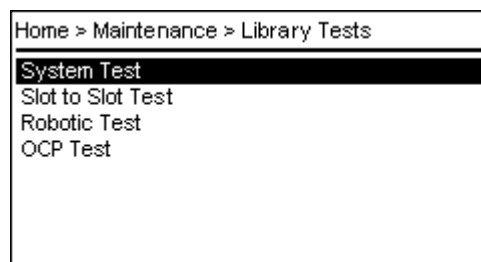

- [System Test](#)
- [Slot to Slot Test](#)
- [Robotic Test](#)
- [OCP Test](#)

**NOTE:** Other Library Tests like the Wellness Test or the Element to Element Test are only available on the RMI. To run these tests, go to the **Maintenance > Library Tests** screen on RMI and select the test from the menu list. See Chapter 6, “Library Tests,” on page 61.

### System Test

The **Maintenance > Library Tests > System Test** screen runs a system test that exercises overall library functionality by moving cartridges from slots to a drive and back.

Library Test > System Test	
<b>Cycles:</b>	1 <input type="button" value="▼"/> <input type="button" value="Start Test"/>
<b>Media:</b>	Seating <input type="button" value="▼"/>
<b>Test Status:</b>	Passed <b>Ticket ID:</b> N/A
<b>Direction:</b>	Drive (1) => Slot (2.28)
<b>Cycles:</b>	1 of 1

Key points about the **System Test** feature:

- During each cycle the library moves a cartridge from a full slot to an empty drive and then returns it to its original slot. You can select the number of cycles for the test. If the test is canceled, the library returns the cartridge to its original slot.
- The library does not move cleaning cartridges during the test.
- The test operates across the entire library and does not consider partition configuration.
- During the test, the library is offline.

Settings for **System Test**:

- **Cycles** – The number of times the test is repeated (**1-10**).
- **Media** – The type of test performed (**Seating** or **Threading**).

### Slot to Slot Test

The **Maintenance > Library Tests > Slot to Slot Test** exercises overall library functionality by moving cartridges between magazine slots.

Library Tests > Slot to Slot Test	
<b>Cycles:</b>	1 <input type="button" value="▼"/> <input type="button" value="Start Test"/>
<b>Test Status:</b>	Not Started
<b>Direction:</b>	N/A
<b>Cycles:</b>	N/A
<b>Ticket ID:</b>	N/A

- During each cycle the library moves a cartridge from a full slot to a randomly-selected empty slot. You can select the number of cycles for the test (**1-10**).
- If the test is canceled, the library completes the current move and then stops.

- The test operates across the entire library and does not consider partition configuration.
- During the test, the library is offline.

### Robotic Test

The **Maintenance > Library Tests > Robotic Test** exercises overall robotic functionality by initializing motors and checking sensors and the barcode reader. During the test the library is offline.

Library Tests > Robotic Test

---

**NOTE:** The robotic test exercises all robotic assembly movements and sensors.

**Test Status:** Not Started

**Ticket ID:** N/A

The **Test Status** field provides the following status information:

- **Not Started**
- **Running**
- **Passed**
- **Aborted**
- **Failed** (a **Ticket ID** for the failure is also shown.)

### OCP Test

The **Maintenance > Library Tests > OCP Test** exercises functionality of the front panel LEDs. The test switches every LED on/off sequentially left to right and right to left. During the test, the library is offline.

Library Tests > OCP Test

---

**NOTE:** The OCP Tests verify front bezel LED functionality and the quality of the LCD display

▼

**NOTE:** The [Reset LCD Adjustment](#) “test” is only available on the RMI.



## View Events

From the **Maintenance > View Events** screen, you can get a quick overview of recent Error and Warning events.

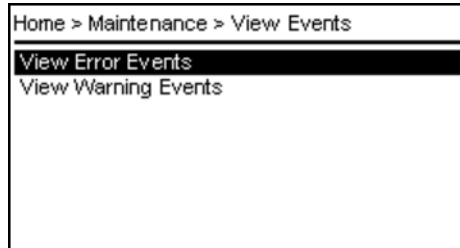

1. Navigate with the **Up/Down** buttons to select an event log:
  - **View Error Events**
  - **View Warning Events**
2. Press **Enter**.

The screen shows these components:

- **Ticket number**
- **Event Code**
- **Time**
- **Component**
- **ID**
- **Description**

**NOTE:** Small arrows on the left and right side indicate that the log contains more than one ticket. To go to the previous/next ticket use the **Left** or **Right** button.

Example of **View Error Events** log:

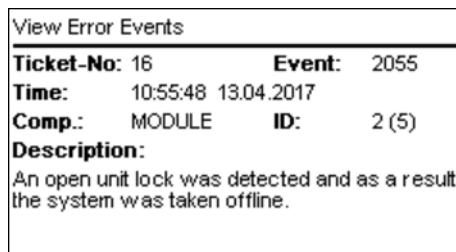

Example of **View Warning Events** log:

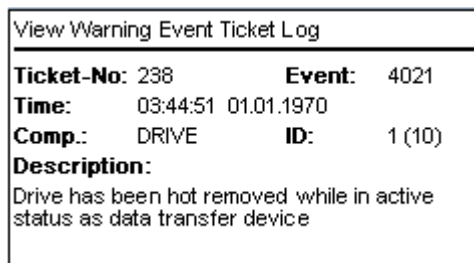

## Drive Logs Download

From the **Maintenance > Drive Logs** screen, you can download logs from every drive that is installed in the library.

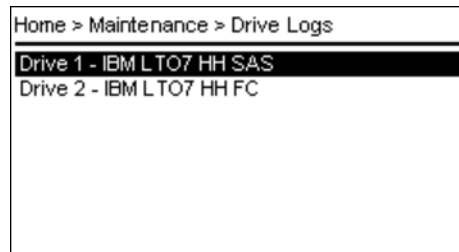

1. Use the **Up/Down** buttons to choose the drive and press **Enter**.
2. Use the **Up/Down** buttons to select the drive log type and press **Enter**.

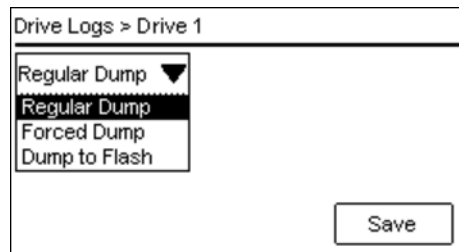

- For the **Regular Dump** and **Forced Dump** log types, a USB device must be in the OCP USB port.
  - The **Dump to Flash** type does not require an USB device; the log is written to the internal flash of the drive.
3. Press the **Down** button to activate the **Save** button and press **Enter** to start the download.

## Library Logs Download

From the **Maintenance > Library Logs** screen, you can download the library logs to an USB device.

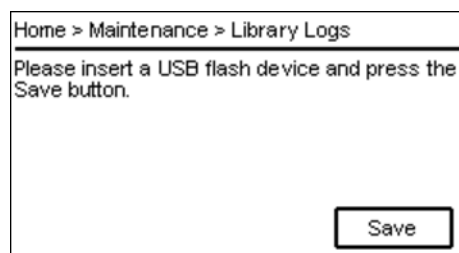

Insert an USB device and press **Enter** to start the download.

## Drive Firmware Upgrade

From the **Maintenance > Drive Firmware Upgrade** screen, you can upgrade one or every drive that is installed in the library.

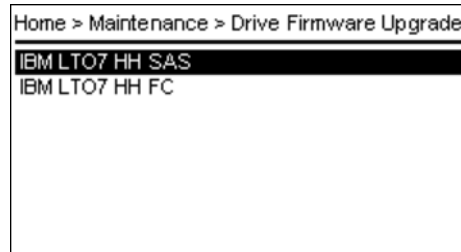

To update the drive firmware, the firmware files need to be available on the USB drive.

1. Use the **Up/Down** button to select a **drive type** from the drive list and press **Enter**.
2. Navigate with the **Up/Down** buttons to select either to upgrade **all installed drives** of the same type (same Generation, Form Factor, and Interface Type) or **one specific drive** of the previously selected type.

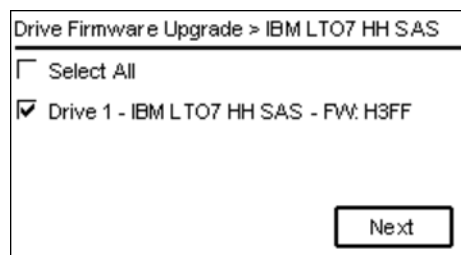

3. Press **Enter** to confirm the choice.
4. Navigate to **Next** and press **Enter**.
5. Use the **Up/Down** buttons to select the firmware image name to use for the upgrade process.

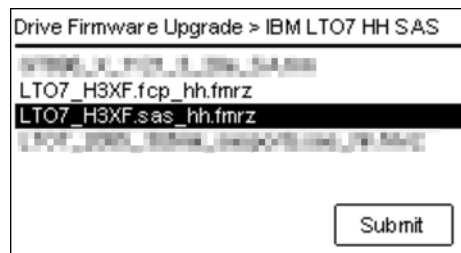

6. Press **Enter** to confirm the choice.
7. Navigate to **Submit** and press **Enter** to start the upgrade process.

## Library Firmware Upgrade

From the **Maintenance > Library Firmware Upgrade** screen, you can upgrade the library firmware. When the library firmware is updated, the library also updates the firmware of the expansion modules to a compatible version.



To update the library firmware, the firmware files need to be available on the USB drive.

1. Insert the **USB device** into the OCP and press **Enter** to continue.

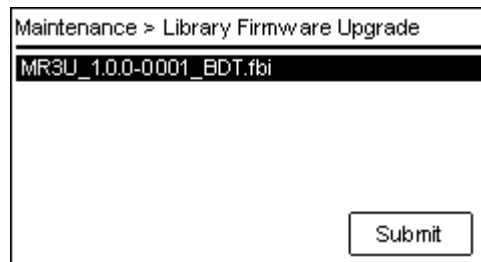

If the USB device has one or more firmware files on it, they are displayed here.

2. Use **Up/Down** to highlight the firmware image name to use for the upgrade process and press **Enter**.
3. Press **Down** to go to **Submit** and press **Enter** to start the upgrade process.

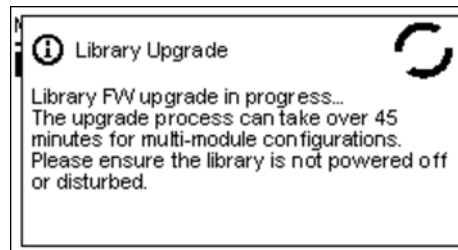

## LCD Adjustment

On the **Maintenance > LCD Adjustment** screen, you can adjust backlight brightness and contrast of the LCD display.

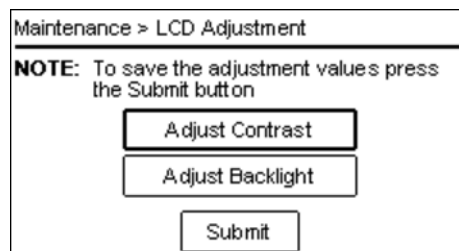

4. Navigate to the **Adjust Contrast** button and press **Enter** to open the contrast adjustment screen.

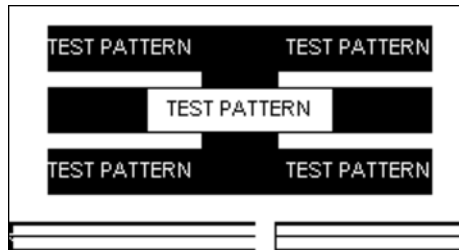

5. Use the **Right** button to move the slider to the right and increase the contrast, or use the **Left** button to move the slider to the left and decrease the contrast.
6. When finished, press **Back** to return to the **Maintenance > LCD Adjustment** screen.
7. Navigate to the **Adjust Backlight** button and press **Enter** to open the backlight adjustment screen.
8. Use the **Right** button to move the slider to the right and increase the brightness, or use the **Left** button to move the slider to the left and decrease the brightness.
9. When finished, press **Back** to return to the **Maintenance > LCD Adjustment** screen.
10. Press **Down** to go to **Submit** and press **Enter** to submit the new adjustment values.

## SSH (Secure Shell)

On the **Maintenance > SSH (Secure Shell)** screen, you can enable the SSH port on the network interface.

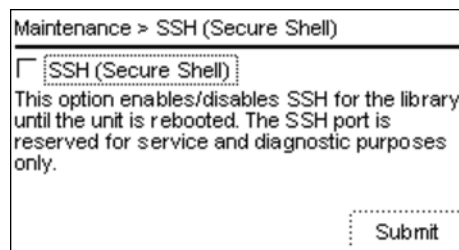

1. Press **Enter** to check the SSH (Secure Shell) box and activate **Submit**.
2. Press **Down** to go to **Submit** and press **Enter** to submit the change.

## Status Menu

Use the navigation buttons to select the **Status** menu on the Home screen.

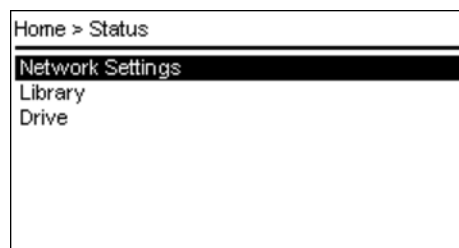

The Status Menu provides the following submenus:

- [Network Settings \(Status\)](#)
- [Library \(Status\)](#)
- [Drive \(Status\)](#)

## Network Settings (Status)

From the **Status > Network Settings** screen you can see the following information about the status of the network settings:

- Host Name
- Domain Name
- Protocol

### General Network Settings

- MAC Address
- Link Status
- Link Speed
- Duplex

### IPv4

- DHCP
- Address
- Netmask
- Gateway
- DNS 1
- DNS 2

### IPv6

- Method
- Address
- Prefix Length
- Gateway
- DNS 1
- DNS 2

## Library (Status)

From the **Status > Library** screen you can see the following library status information.

- Library Status
- Module Status for each module in the stack (up to seven)

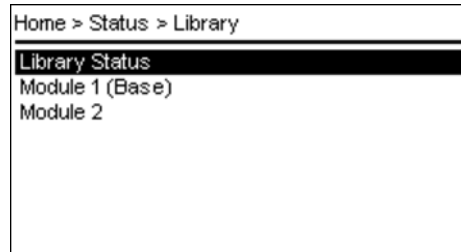

### Library Status Screen

The **Status > Library > Library Status** screen provides the following status information:

#### Library Information:

- Vendor
- Product ID
- Serial Number
- Base Firmware Revision
- Expansion Firmware Revision
- Robotic Hardware Revision
- Robotic Firmware Revision
- Barcode Reader Hardware Revision
- Barcode Reader Firmware Revision

#### Library Status:

- Library Status – For example, **Scanning**, **Moving**, and **Idle**
- Total Power On Time – Days/Hours/Minutes
- Cartridge in Transport – Source slot of current moving cartridge
- Odometer – Robotic assembly move count
- Robotic Location – Position in stack
- Shipping Lock – **Locked** or **Unlocked**

### Module Status Screen

The **Status > Library > Module #** screen provides the following status information:

- Controller Revision – Base/Expansion controller
- Power Supply Status – Displays the power redundancy status
- Lower Power Supply – **Present** or **Not Present**
- Upper Power Supply – **Present** or **Not Present**

### Drive (Status)

From the **Status > Drive** screen, you can see the configuration and status of each drive that is installed in the library. Use **Up/Down** buttons to select a drive from the drive list. The drive list already shows the powered status of the drives (**On** or **Off**).

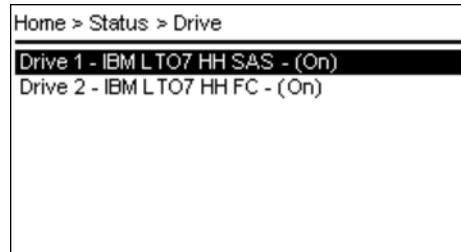

The **Status > Drive > Drive #** screen provides the following status information:

- Vendor
- Personality
- Firmware
- Generation
- Form Factor – **HH** or **FH**
- Interface Type – **FC** or **SAS**
- Manufacturer S/N
- Powered – **On** or **Off**
- WWNN
- Temperature
- Logical Library
- Encryption
- Cartridge – Barcode label or **N/A** if no cartridge loaded
- Module Location
- Cooling Fan Status – **Active** or **Not Active**

#### **Fibre Channel Drive: Status for Port 0 and Port 1 (if present)**

- WWPN
- Speed
- Port Type
- Port ID or Loop ID / ALPA
- Interface

#### **SAS Drive: Status for Port 0 and Port 1**

- WWPN
- Interface
- Speed

## Logout

Use the navigation buttons to select the **Logout** menu on the Home screen.

With the **Logout** screen, you can exit the current session on the OCP display and return to the default login screen. You only have to press **Enter** as **Submit** is pre-selected on the screen.



# Remote Management Interface

The Remote Management Interface (RMI) is a web interface for NEOxl 40 Tape Library that provides access via a browser to all the library configurable features, includes online help, and is easier to use than the OCP.

The RMI main page is organized into the following regions:

- **Top Banner** – Contains the Home, Logout, and Help (?) buttons and displays the overall status and general information about the library and user.
- **Left Pane** – Displays the library identity and module status.
- **Center Pane** – Provides access to operate and configure the library and to view additional status information.
- **Right Pane** – Displays a log of recent events (Home page default) or additional functions when a Center Pane option is selected.







## Topics in Remote Management Interface:

- [Home Page Element Details](#)
- [RMI Configuration Options](#)
- [RMI Maintenance Options](#)
- [RMI Operation Options](#)
- [RMI Status Options](#)

## Home Page Element Details

Details for the Top Banner, Left Pane, Center Pane, and Right Pane sections of the RMI default Home page.

### RMI Top Banner Elements

- **Home Icon** () – Click the Home icon to return to the library main page.
- **Library Health** – An icon indicating the overall health status of the library.
  - **OK Status Icon** () – The green check mark icon indicates that all library components are fully operational and that no user intervention is required.
  - **Warning Status Icon** () – The yellow triangle exclamation point icon indicates that user attention is necessary but that the library can still perform most operations. Click the icon to display the event ticket log.
  - **Error Status Icon** () – The red circle X icon indicates that user intervention is required and the library is not capable of performing some operations. Click the icon to display the event ticket log.
- **Status** – The status of the library robotics.
  - **Idle** – The library robotics is ready to perform an action.
  - **Moving** – The library robotics is moving a cartridge.
  - **Scanning** – The library robotics is performing an inventory of cartridges.
  - **Offline** – The library robotics has been taken off line by the library.
- **Library Time & Date** – Helpful information when analyzing event logs and support tickets, and might be needed when contacting support.
- **User** – The user account logged in for this session.
- **Logout** () – Logs out of this RMI session and changes view to Login page.
- **Help** () – Accesses the library online help.

### RMI Left Pane Elements

- **Serial #** – The serial number of the Base Module.
- **Hostname** – The library hostname.
- **IPv#** – The IP version (IPv4 or IPv6) and IP address.
- **Firmware** – The library firmware version.
- **Module Status Overviews** – A summary of each module's configuration and health. Click the module status area to select a different module.

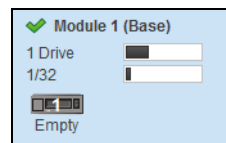

- **Module Health Icon** – An icon that indicates the health of the library (green OK, yellow warning, or red error).
- **Module Number** – Modules are numbered based on their location in the physical library starting with the bottom module as **Module 1**. The Base Module is annotated with **(Base)**.
- **Drive Status** – The number of drives installed in the module, the health of each drive (color code), and a bar indicating the drives installed. Click the drive bar rectangle to display the drive configuration and status information pop-up.

- A **black rectangle** indicates that the drive is fully operational and that no user intervention is required.
- A **yellow rectangle** indicates that user attention is necessary but that the drive can still perform most operations.
- A **red rectangle** indicates that user intervention is required or that the drive is not capable of performing some operations.
- **Magazine Slot Usage** – The slot number in use / total number of cartridge slots available. Click the slot bar on the right to display cartridge inventory and status information (**Status > Cartridge Inventory > List View**).
- **Drive Status** – The current drive activity for each drive in the module. The drive operation status is only displayed for the selected module. Click the drive icon to display the drive configuration and status information pop-up. The text below the icon is the current status:
  - **Write** – The drive is performing a write operation.
  - **Read** – The drive is performing a read operation.
  - **Idle** – A cartridge is in the drive but the drive is not performing an operation.
  - **Empty** – The drive is empty.
  - **Encryp** – The drive is writing encrypted data.

## RMI Center Pane Elements

**NOTE:** When logged in as a general User, the only option available is the blue Status button. The other buttons are inactive and white to indicate Administrator usage only. The Service button is only shown when logged in as Service user.

Oversize buttons are shown that provide links to the following:

- **Open Mailslot** – Click to unlock the mailslot on the selected module. Mailslots must be enabled before the slots can be used as mailslots. For information about using RMI to do this, see [Mailslot Configuration on page 88](#).
- **Open Magazine** – Click to unlock a magazine in the selected module. Only one magazine in the library can be open at a time. For information about using RMI to do this, see [Open a Magazine on page 111](#).
- **Configuration** – Click to configure the library. See [RMI Configuration Options on page 76](#).
- **Maintenance** – Click to access maintenance functions. See [RMI Maintenance Options on page 99](#).
- **Operation** – Click to access operation functions. See [RMI Operation Options on page 109](#).
- **Status** – Click to access status information. See [RMI Status Options on page 113](#).

## RMI Right Pane Elements

Displays a log of recent events (Home page default) or additional options when a Center Pane option is selected. Options that have suboptions display a double down arrow (▾).

### Open Mailslot

- Move Media
- Open Mailslot
- Open Magazine
- Clean Drive
- Rescan Inventory
- Force Drive Media Eject

(Same as  
**Operation > Open Mailslot**)

### Open Magazine

- Move Media
- Open Mailslot
- Open Magazine
- Clean Drive
- Rescan Inventory
- Force Drive Media Eject

(Same as  
**Operation > Open Magazine**)

### Configuration

- Initial Configuration Wizard
- System
- Network
- Network Management
- Drives
- Mailslots
- Partitions
- Encryption
- User Accounts
- Web Management

### Maintenance

- Library Tests
- Logs and Traces
- Firmware Upgrades
- Download Drive Logs
- System Reboot
- Drive Reboot
- UID LED Control
- Move Robotic to Base Module
- Support Information

### Operation

- Move Media
- Open Mailslot
- Open Magazine
- Clean Drive
- Rescan Inventory
- Force Drive Media Eject

### Status

- Library Status
- Cartridge Inventory
- Partition Map
- Drive Status
- Network Status
- Security

### Configuration Suboptions

- System
  - Save/Restore Configuration
  - Date and Time Format
  - Media Barcode Compatibility Check
  - Allow Unlabeled Media
  - License Key Handling

- Network Management
  - SNMP
  - SMTP
  - Remote Logging (rsyslog)

- Drives
  - Settings

- Partitions
  - Basic Wizard
  - Expert Wizard

- Encryption
  - KMIP Wizard

- User Accounts
  - User Accounts Settings
  - Local User Accounts
  - LDAP
  - Kerberos

## Maintenance Suboptions

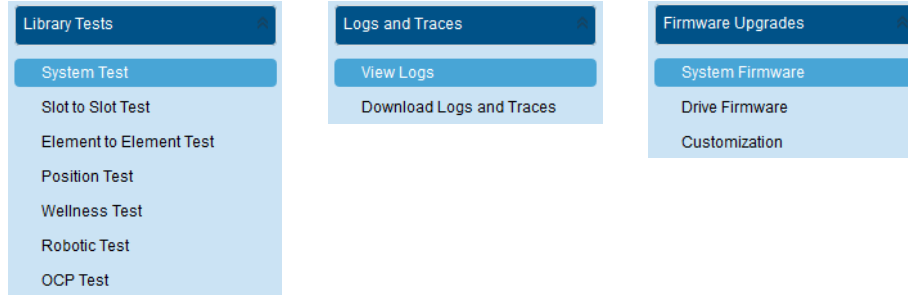

## Status Suboptions

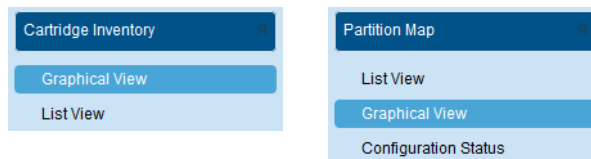

## RMI Configuration Options



To configure the NEOxl 40 Tape Library with the RMI, at the main page click **Configuration**. The **Configuration** page has numerous options in the Right Pane from which to select.

- [Initial Configuration Wizard](#)
- [System Configuration](#)
- [Network Configuration](#)
- [Network Management](#)
- [Tape Drive Configuration](#)
- [Mailslot Configuration](#)
- [Partition Configuration](#)
- [Encryption Configuration](#)
- [User Accounts Configuration](#)
- [Web Management Configuration](#)

### Initial Configuration Wizard

This is the same wizard you ran in the OCP when the library was first turned on. If, at a minimum, the network settings have been configured, you can rerun the wizard in RMI to set the administrator password, network configuration, timezone selection, date and time settings, and then update the configuration. Use the **Next**, **Back**, and **Finish** buttons to go through the wizard.

## System Configuration

The **Configuration > System** option has the following suboptions:

- [Save/Restore Library Configuration](#)
- [Date and Time Format](#)
- [Media Barcode Compatibility Check](#)
- [Allow Unlabeled Media](#)
- [License Key Handling](#)
- [RMI Timeout](#)

### Save/Restore Library Configuration

A saved configuration database makes it easier to recover the library configuration if you need to replace either the Base Module or Base Module Controller. There are also options to reset the library to its default settings and update the list of known drives and modules.

**Configuration > System > Save/Restore Configuration**

▲ Save Configuration File

Save ...

▲ Restore Configuration File

Configuration File  No file selected.

▲ Reset Default Settings

Reset

▲ Reset the List of Known Drives and Modules

**NOTE:** Resetting the list of known drives and modules will cause the library to re-discover only the drives and modules that are physically present. This operation will alter the list of element addresses reported to hosts and will re-number the drives and modules. This operation cannot be undone. After the operation completes, use one of the partition wizards to modify partitioning as needed.

Reset

To save a configuration file:

1. Navigate to **Configuration > System > Save/Restore Configuration**.
2. Under **Save Configuration File**, click **Save**.  
This downloads the configuration file to the browser or system running the RMI. A message displays that the file is being saved.
3. When the buttons appear, click **Download**.
4. Select **Save File** and click **OK** to save the zip file.

To restore a previously saved configuration file:

1. Navigate to **Configuration > System > Save/Restore Configuration**.
2. Click the **Restore Configuration File** bar to open it.
3. Click **Browse** to navigate to and select the saved configuration file.  
The zip file normally starts with "**sysconf-**".
4. Click **Open**.

5. Click the **Upload File & Restore** button that displays in the Restore section.

This starts the uploading process and restores the configuration file from the system running the RMI. A messages show the upload and library restart. Once the library comes back online, you need to log back in.

To reset the library configuration to its default settings:

1. Navigate to **Configuration > System > Save/Restore Configuration**.
2. Click the **Reset Default Settings** bar to open it.
3. Click **Reset**.

For information on the default settings, see [Default Settings on page 190](#) in [Appendix C, "Technical Specifications."](#)

To reset the List of Known Drives and Modules:

1. Navigate to **Configuration > System > Save/Restore Configuration**.
2. Click the **Reset the List of Known Drives and Modules** bar to open it.
3. Click **Reset**.

This feature does a re-discovery of installed hardware components. During this discovery, any modules and drives that are no longer in the library stack are removed from the list.

## Date and Time Format

**NOTE:** The library does not adjust its time for daylight savings time. The time must be adjusted manually.

To configure date and time format parameters and use an SNTP server, navigate to **Configuration > System > Date and Time Format**.

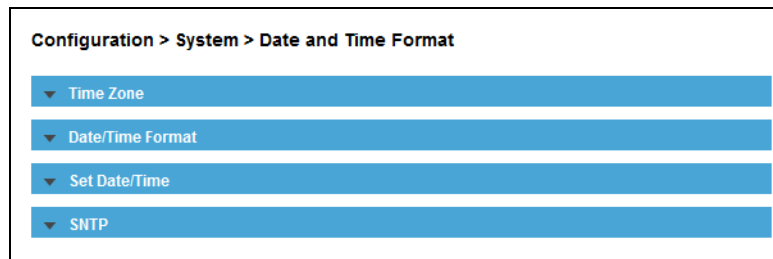

To set the time zone for the library clock:

1. Click the **Time Zone** bar to open the option.  
A list of continents, countries, and regions is displayed.
2. Select a **location** from the list.  
When an item selected is preceded with a greater than sign (>) symbol (for example, > **US**) is shown in a column, a submenu of locations is displayed in the next column.

**Time Zone**

Current Time Zone: GMT

Time Zone List

> Africa	> Argentina	Buenos_Aires
> America	> Indiana	Catamarca
> Antarctica	> Kentucky	ComodRivadavia
> Arctic	> North_Dakota	Cordoba
> Asia	Adak	Jujuy
> Atlantic	Anchorage	La_Rioja
> Australia	Anguilla	Mendoza
> Europe	Antigua	Rio_Gallegos
> Indian	Araguaina	Salta
> Pacific	Aruba	San_Juan

Submit

- If an expanded time zone list is shown in the next column, repeat [Step 2](#) until a location with the appropriate time zone is visible (no “>”) and select that **location**.
- Click **Submit**.

To set the date and time formats:

- Click the **Date/Time Format** bar to open the option.

**Date/Time Format**

Time Format: 24 Hours (hh:mm:ss)

Date Format: (DD.MM.YYYY)

Submit

- From the drop-down list, select a **Time Format**.
- From the drop-down list, select a **Date Format**.

For example, depending on the format selected, June 30, 2018 is displayed as:

- **DD.MM.YYYY** – “30.06.2018”
- **MM/DD/YYYY** – “06/30/2018”
- **YYYY-MM-DD** – “2018-06-30”

- Click **Submit**.

To set the library clock to the current date and time:

- Click the **Set Date/Time** bar to open the option.

**Set Date/Time**

Time: 13:32:18 24 Hours (hh:mm:ss)

Date: 15.03.2018 (DD.MM.YYYY)

Submit Now

- Enter the **time and date** in the given format.  
Alternately, to use current time and date of the local PC, click **Now**.
- Click **Submit**.

The library must have network access to an SNTP (Simple Network Time Protocol) server to set the library clock using an SNTP server:



1. Click the **SNTP** bar to open the option.

1. Check the **SNTP Enabled** box.
2. Enter the **SNTP Server** address.
3. Click **Submit**.

### Media Barcode Compatibility Check

To enable or disable the barcode media ID check, navigate to **Configuration > System > Media Barcode Compatibility Check**. To disable, uncheck the option box and click **Submit**.

When the **Barcode Media ID Restriction** box is checked, the library only allows tape cartridges with the appropriate barcode media ID (the last two characters of the barcode) to be loaded into tape drives. For example, an LTO-8 labeled cartridge is not allowed to be moved into an LTO-7 tape drive.

When disabled, the library moves any tape into any tape drive. If the cartridge is incompatible with the tape drive, the library displays an error message.

**NOTE:** It is strongly recommended that ALL cartridges have barcode labels with the correct media ID, and that the Barcode Media ID Restriction is enabled.

### Allow Unlabeled Media

To allow or disallow cartridges without labels from being used in the library, navigate to **Configuration > System > Allow Unlabeled Media**. To disallow, uncheck the option box and click **Submit**.

## License Key Handling

To add or delete a license key, navigate to **Configuration > System > License Key Handling**.

To add a license key:

1. Enter a **license key**.  
The license key needs to have a length of 15 characters
2. Click **Add License**.

To delete all license keys:

**NOTE:** The button for deleting all license keys is only available on Service level.

1. Click **Delete License Key(s)**.



**IMPORTANT:** Clicking the **Delete License Key(s)** button deletes all license keys currently in the library. All currently installed license keys are listed under the **License Key(s) in System** bar.

2. At the warning message, click **OK** to complete the action.

## RMI Timeout

To set the timeout for RMI, navigate to the **Configuration > Web Management > Session Timeout** page.

**NOTE:** The timeout is only selectable for RMI. The timeout for OCP is always set to 5 Minutes.

1. From the drop-down menu, select a **timeout value** (5 or 30 minutes).
2. Click **Submit**.

## Network Configuration

The **Configuration > Network** option is used to configure the following items:

- [General Network Settings](#)
- [Primary Network Port](#)
- [Secondary Network Port](#)

- [Reset Internal IP Range](#)

### General Network Settings

The Host Name and Domain Name that was configured with the Initial Configuration wizard are used to access the RMI:

“<Host Name>.<Domain Name>”

To change these settings:

1. Navigate to the **Configuration > Network** page.
2. With the **General Network Settings** option opened, update the **Host Name** and **Domain Name**.
3. Click **Submit**.

### Primary Network Port

Use these settings to change the primary port's configuration.

1. With the **Primary Network Port** option opened, use the two drop-down menus to select the following:
  - **Protocol** – Select either **IPv4**, **IPv6**, or **IPv4 & IPv6**.
  - **Max. Link Speed** – Select either **10 Mbit**, **100 Mbit**, or **1 Gbit (default)**.
2. Based on the Protocol setting selected, use the **IPv4** and/or **IPv6** sections to configure the **protocol settings**.

To have the library obtain an IP address from a DHCP server instead of a Static IP address, select the **DHCP** (IPv4) or **Stateless** (IPv6) method.

### 3. Click **Submit**.

#### Secondary Network Port

If a secondary network port is used, open the **Secondary Network Port** option, check the **Port Enabled** box, and configure the same options as used for the Primary Network Port.

#### Reset Internal IP Range

**NOTE:** Only reset the internal IP range if you are using the same range in your network environment.

To reset the internal IP range, open the **Reset Internal IP Range (in case of conflict)** bar and click **Submit**.

For internal communication between modules the tape library uses an Ethernet connection with an internal IP address range. To prevent any conflict between the internal IP address range and the external IP addresses, it is necessary to select the internal IP range before the tape library gets connected to the external Ethernet port.

A file which contains the internal IP range is stored on the Base Module backplane (/opt/storage/mfg/stack/network.range and LCM /opt/storage/configuration/network.range).

The file is created through the **OCP IP Range** selection screen when the NEOx1 40 Tape Library starts for the very first time or if the library is reset to Manufacturing Defaults. The file can be reset via either OCP or RMI.

The Values must be in the following format:

**RANGE=192.0.2**

**NOTE:** The last section of the IP address is not set because it is set internally.

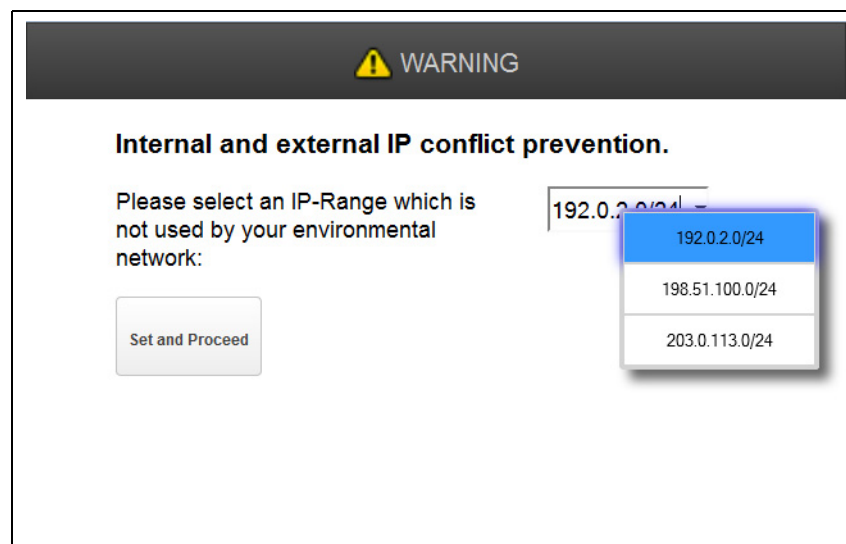

## Network Management

The **Configuration > System** page has the following suboptions:

- [SNMP Configuration](#)
- [SMTP Configuration](#)
- [Remote Logging \(rsyslog\)](#)

## SNMP Configuration

Use the **Configuration > Network Management > SNMP** page to enable and configure SNMP (Simple Network Management Protocol), which allows applications to manage the device. The library supports both SNMP configuration and SNMP traps.

**Configuration > Network Management > SNMP**

**SNMP**

SNMP Enabled:  Download MIB File

Community Name:

Notification Level:

**SNMP Targets**

IP/Hostname	Port	Version	Community	Action
<input type="text"/>	162	SNMPv1	public	<input type="button" value="Edit"/> <input type="button" value="Delete"/>

**The configuration options below are only needed when using SNMPv3.**

Limit all library SNMP communication to SNMPv3:

SNMPv3 Security Level:

Authentication User Name:

Authentication Password:

NOTE: Needed for security levels authNoPriv and authPriv (8 -31 characters)

Authentication Protocol:

NOTE: Needed for security levels authNoPriv and authPriv

Privacy/Encryption Protocol:

NOTE: Needed for security level authPriv

Privacy/Encryption Passphrase:

NOTE: Needed for security level authPriv (8 -31 characters)

General SNMP settings:

- **SNMP Enabled** – When checked, SNMP and its configuration is enabled so that the library can be managed by computers listed in the **SNMP Targets** list.
- **Download MIB File** – Click to download an MIB file.
- **Community Name** – A string used to match the SNMP management station and library. It must be set to the same name on both the management station and the library. The default community name is **public**.
- **Notification Level** – Use the drop-down box to select the types of events for which the library should send email.
  - **Inactive** – No events are sent.
  - **Critical** – Only critical events are sent.
  - **+ Warnings** – Only critical and warning events are sent.
  - **+ Configuration** – Only critical, warning, and configuration events are sent.

- **+ Information** – All events are sent.

With SNMP enabled, you can add, edit, or delete target information for an SNMP target.

To **add** or **edit** an SNMP target:

1. In the list, click **Edit** for the appropriate SNMP target.  
When adding a new SNMP target, click **Edit** next to a target without an **IP/Hostname**.
2. Enter or change the target **IP address or hostname**.
3. Enter or change the **port number**.
4. From the drop-down menu, select or change the **SNMP version**.
5. Enter or change the SNMP **community string** for the target.  
Normally, it is **public**.
6. If adding a new SNMPv3 target, also complete the **SNMPv3 fields** below the list.
7. Click **Submit**.

To **delete** an existing SNMP target:

1. In the list, click **Delete** next to the target to be deleted.
2. Click **Submit**.

To clear any SNMPv3 options previously entered, click **Clear SNMPv3 Options** and confirm.

### SMTP Configuration

From the **Configuration > Network Management > SMTP** page, you can enable SMTP (Simple Mail Transfer Protocol) functionality and configure email notification of library events. The library must have network access to an SMTP server.

**Configuration > Network Management > SMTP**

**SMTP**

SMTP Enabled:

Notification Level:

SMTP Server:

Security:

SMTP Port:

To Email Address:

Mailer Name:

Email Subject:

Emailer Address:

Authentication Required:

Username:

Password:

**NOTE:** The Submit button will perform any changes made on the page and send a test email.

- **SMTP Enabled** – Check to enable SMTP and activate the configuration settings.

- **Notification Level** – Use the drop-down box to select the types of events for which the library should send email.
  - **Inactive** – No events are sent.
  - **Critical** – Only critical events are sent.
  - **+ Warnings** – Only critical and warning events are sent.
  - **+ Configuration** – Only critical, warning, and configuration events are sent.
  - **+ Information** – All events are sent.
- **SMTP Server** – Enter the Hostname or IP address of the SMTP server.
- **Security** – Use the drop-down box to select the Security protocol for accessing the SMTP server. Choose from **None**, **SSL/TLS**, or **STARTTLS**.
- **SMTP Port** – Use the drop-down box to select the SMTP server port. The default port for the selected protocol is selected. You can choose one of the default ports or configure a custom port.
- **To Email Address** – Enter the email address to receive the reported events (for example, firstname.lastname@example.com). Only one email address can be configured.
- **Mailer Name** – Enter the name of the sender of the notification email.
- **Email Subject** – Enter the subject line for the email message.
- **Mailer Address** – Enter the return address to use for the email message.
- **Authentication Required** – When checked, a user name and password are required to access the SMTP server. The appropriate fields are activated.
- **Username** – User account for logging into the SMTP server when authentication is required.
- **Password** – The password associated with the Username when authentication is required.

Click **Submit** to make the changes and send a test email.

### Remote Logging (rsyslog)

Use the **Configuration > Network Management > Remote Logging (rsyslog)** page to enable remote logging into the library.

- **Remote Logging Enabled** – Check to enable remote logging and activate the configuration settings.
- **Notification Level** – Use the drop-down box to select the types of events for which the library should send email.
  - **Inactive** – No events are sent.
  - **Critical** – Only critical events are sent.

- **+ Warnings** – Only critical and warning events are sent.
- **+ Configuration** – Only critical, warning, and configuration events are sent.
- **+ Information** – All events are sent.
- **Remote Logging Server** – Enter the Hostname or IP address of the Remote Logging server.
- **Remote Logging Port** – Use the drop-down box to select the Remote Logging server port. You can choose the default port or configure a custom port.
- **Transport Protocol** – Use the drop-down box to select the transport protocol for accessing the Remote Logging server. Choose from **UDP** or **TCP**.

## Tape Drive Configuration

Use the **Configuration > Drives > Settings** page to view and modify drive settings.

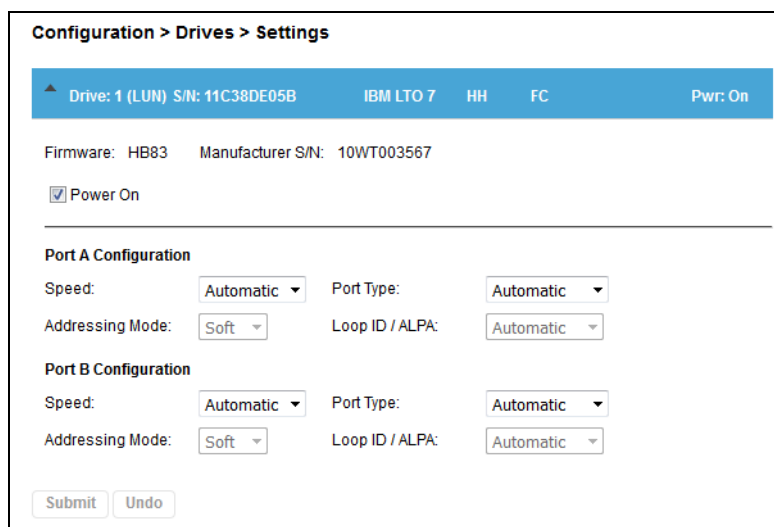

Drive information is shown in the option bar:

- **Drive number** – Drives are numbered from the bottom of the library up beginning with one. The drive currently hosting the SCSI communication for the library is designated with (LUN).
- **Serial Number (S/N)** – The serial number assigned to the tape drive by the library. This serial number is reported to host applications. The serial number cannot be modified.  
This is not the serial number assigned to the drive by the manufacturer. That serial number is shown in **Manufacturer S/N**.
- **LTO generation** – The supported version of the LTO drive:
  - **LTO-7** – LTO-7 Ultrium Tape Drive
  - **LTO-8** – LTO-8 Ultrium Tape Drive
- **Drive form factor:**
  - **HH** – Half height
  - **FH** – Full height
- **Drive interface:**
  - **FC** – Fibre Channel
  - **SAS** – Serial Attached SCSI



- **(Modified)** – When this text is present, it indicates that one or more settings have been changed.
- **Power Status (Pwr:)** – Indicates whether the drive is currently powered ON or OFF.

Additional information is shown below the option bar:

- **Firmware** – The version of firmware currently installed on the drive.
- **Manufacturer S/N** – The serial number assigned to the drive when it was manufactured. Use this serial number when working with technical support.

Configurable options:

- **Power On** – Checked when the drive is powered ON. Uncheck the box to power off the drive.

**NOTE:** Always power off a tape drive before removing it from the library or moving it to a new location within the library.

- **Port *x* Configuration (FC only)** – Port configuration settings for each port on an FC drive.
  - **Speed** – Use the drop-down box to select a speed. The default is **Automatic**. Choices are **2 GB/s**, **4 GB/s**, or **8 GB/s**.
  - **Port Type** – Use the drop-down box to select a type. The default is **Automatic**. Choices are **Loop** and **Fabric**.
  - **Addressing Mode** – When **Port Type** is set to **Loop**, you can choose an **Addressing Mode**. Choices are **Soft** and **Hard**.
  - **Loop ID / ALPA** – When **Addressing Mode** is set to **Hard**, you can choose an ALPA address from the drop-down list.

To apply the changes, click **Submit**. To reset all changed fields to their previously saved values, click **Undo**.

## Mailslot Configuration

The **Configuration > Mailslot** page lists each of the mailslots and shows whether each is enabled or disabled. To change the state, click the status button for the appropriate mailslot and then click **Submit**. Slots not enabled as mailslots are available as storage slots.

Configuration > Mailslots		
Module	Mailslot Magazine	
Module 2	Disabled	Enable
Base	Enabled	Disable

Submit

## Partition Configuration

Use the **Configuration > Partitions** wizards to configure or change partitions in the library.

**NOTE:** To configure the number of barcode characters to report to the host application and whether to report them from the left or right end of the label, use either the **Basic Partition Wizard** or **Expert Partition Wizard** to change the setting.

**Configuration > Partitions**

When changing certain configuration options the library will go offline to hosts. Only perform these config changes when it is acceptable for the library to go offline.

**Basic Partition Wizard:**  
Use this simplified partition wizard to create one or more partitions that include all of the library elements.  
NOTE: Using this wizard will delete any existing partitions that are already created.

**Expert Partition Wizard:**  
Use this wizard to create or modify customized partitions, as well as to configure advanced partition options.

The library has a flexible partitioning scheme with a few key constraints:

- Each partition must have at least one tape drive.
- One drive in each partition hosts the library LUN for the partition.
- The maximum number of partitions is 21.
- Magazine slots are allocated in five-slot groups.
- Mailslots must be enabled for a module before they can be allocated to a partition.

A partition does not need to have a mailslot. If a partition does not have a mailslot, the full magazine must be accessed to import or export cartridges. Opening a magazine takes the library offline.

Although mailslot magazines can be shared between partitions, the mailslots are assigned individually to partitions.

The wizards guide you through the partition configuration process. The wizards are only accessible from the RMI.



**CAUTION:** The library goes offline while partitions are being configured. Ensure that all host operations are idle before running either partition wizard.

---

**Tip:** You can use the **Expert Partition Wizard** to adjust the allocation of resources after first creating the partitions with the **Basic Partition Wizard**.

The **Configuration > Partitions** page has the following suboptions:

- [Basic Partition Wizard](#)
- [Expert Partition Wizard](#)

### Basic Partition Wizard

Use the **Basic Partition Wizard** to configure partitions that will have similar resources. The wizard removes the current partition configuration and assigns the drives and storage slots as evenly as possible to the partitions. Any extra drives or slots are assigned to the first partition.

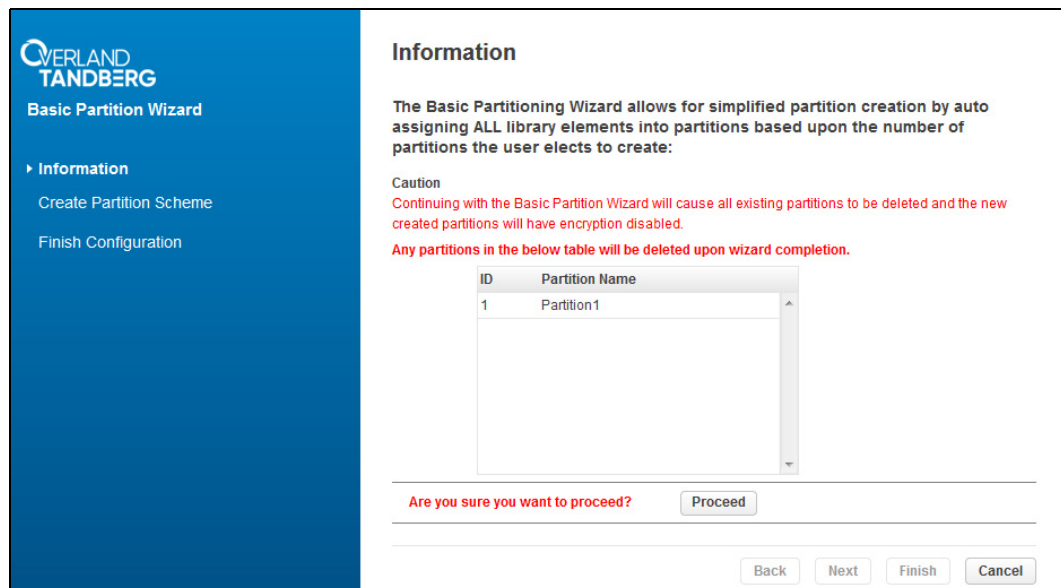

**NOTE:** For a library with a single partition, use it to configure the number of barcode characters to report to the host application and whether to report them from the left or right end of the label.

1. Navigate to **Configuration > Partitions > Basic Wizard** to start the wizard.  
If partitions already exist, the **Information** page displays them. They will be deleted by the wizard. You can **Cancel** to keep existing partitions.
2. To proceed, click **Proceed** and then click **Next**.
3. The **Create Partition Scheme** page displays the number of slots, mailslots, tape drives, and maximum available partitions for the library.

**NOTE:** If you want to enable or disable the mailslots, Cancel out of the wizard and update the mailslot configuration before configuring partitioning.

4. Select the **number of partitions**.
5. Select the **number of barcode characters** reported to the host application.  
This option provides interchange compatibility with libraries with more limited barcode reading capabilities. The maximum length is fifteen and the default is eight. This configuration is apply to all partitions.  
**NOTE:** The industry standard length for LTO barcode labels is eight characters. Barcode labels longer than eight characters might scan incorrectly, particularly if they are not high quality labels.
6. Select whether to report the barcode characters from the **left** or **right** end of the barcode label to the host application when reporting fewer than the maximum number of characters.  
For example, when reporting only six characters of the barcode label **12345678**, if alignment is left, the device reports back **123456**. If alignment is right, the device reports back **345678**. The default is left.

7. Click **Next**.  
The **Finish Configuration** page displays the proposed allocation of library resources into partitions.

8. Do **one** of following:
  - To make other changes to the configuration, click **Back**.
  - To have the wizard configure partition as shown, click **Finish**.
 After the wizard reconfigures the partition, the library comes back online automatically.
9. To exit the wizard, click **Exit**.

### Expert Partition Wizard

Use the **Expert Partition Wizard** to configure partitions that will have different resources or to adjust resource assignments for existing partitions or those created with the Basic Partition Wizard. This wizard can add or remove partitions from the current partitions configuration and then edit each partition configuration to add or remove library resources.

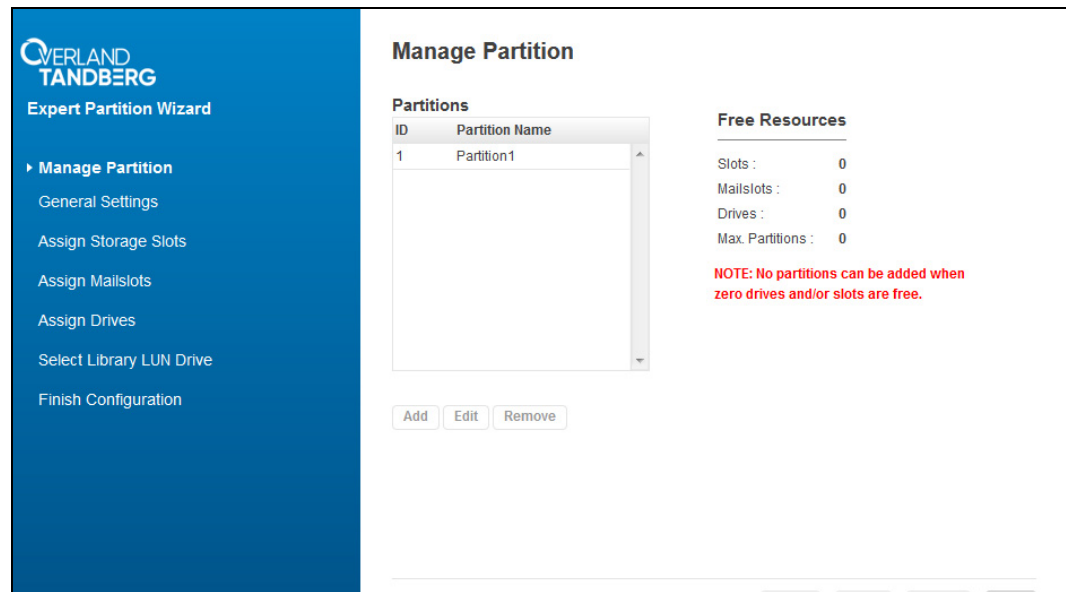

Click **Configuration > Expert Wizard** to start the wizard. The **Create Partition Scheme** page lists the current partitions (if any) and the free resources. Use the wizard to configure one partition at a time.

**NOTE:** If you want to enable or disable the mailslots, **Cancel** out of the wizard and update the mailslot configuration before configuring partitioning.

To **add** a partition:

**NOTE:** The add option and **Add** button is only active if there are available resources. If there are no available resources, either edit a partition to release resources from it or remove a partition that contains extra resources.

1. Click **Add** and then click **Next**.
2. Enter a **name** for the partition.
3. Select the **number of barcode characters** reported to the host application.
 

This option provides interchange compatibility with libraries with more limited barcode reading capabilities. The maximum length is fifteen and the default is eight. This configuration applies to all partitions.

**NOTE:** The industry standard length for LTO barcode labels is eight characters. Barcode labels longer than eight characters might scan incorrectly, particularly if they are not high quality labels.

4. Select whether to report the barcode characters from the **left** or **right** end of the barcode label to the host application when reporting fewer than the maximum number of characters.

For example, when reporting only six characters of the barcode label **12345678**, if alignment is left, the device reports back **123456**. If alignment is right, the device reports back **345678**. The default is left.

5. Click **Next**.
6. In the **Assign Storage Slots** page, use the **>>** and **<<** buttons to assign slots to the new partition and then click **Next**.
7. In the **Assign Mail Slots** page, use the **>>** and **<<** buttons to assign mailslots to the new partition and then click **Next**.  
Individual mailslot elements cannot be shared between partitions. Importing or exporting cartridges in a partition without an assigned mailslot requires magazine access, which takes the library offline.
8. In the **Assign Drives** page, use the **>>** and **<<** buttons to assign drives to the new partition and then click **Next**.
9. If the partition has multiple tape drives, select the **drive that hosts the SCSI communication** for the partition and then click **Next**.  
The lowest numbered drive in the partition is the default.
10. Verify the partition configuration and then click **Finish**.  
After the wizard reconfigures the partition, the library comes back online automatically.

To **remove** a partition:

1. Select the **partition**, click **Remove**, and then click **Next**.
2. Verify that you want to remove the partition, and then click **Finish**.

After the wizard removes the partition, the library comes online automatically.

## Encryption Configuration

This option is only accessible by a Security user.

**Configuration > Encryption**

When changing certain configuration options the library will go offline to hosts. Only perform these config changes when it is acceptable for the library to go offline.

**Set Default Encryption Mode for new Partitions**

Set the default encryption mode for new Partitions. Will be used if a partition gets created:

Controlled by Backup Application ▼    Apply to all existing partitions

**General Settings**

Allow Administrator encryption configuration during Expert Partition Wizard

Note: Enabling this selection allows library administrators to enable and disable encryption on a per-partition basis, without needing further approval from the Security user.

**Set Encryption Mode per Partition**

Partition1:    Controlled by Backup Application ▼

Submit

When logged in as a Security user, use this option to control the encryption of partitions or entire library.

Under **Set Default Encryption Mode for New Partition**, use the drop-down menu to select if new partitions are encrypted by the backup application or if licensed KMIP encryption is used. Click **Apply to All Existing Partitions** if you want encryption on previously created partitions.

Under **General Settings**, check the box to allow an Administrator to enable or disable encryption on a per-partition basis bypassing Security.

Under **Set Encryption Mode per Partition**, use the drop-down menus to select the encryption for each existing partition.

If KMIP encryption is licensed, you can run the **KMIP Wizard** to configure it.

## User Accounts Configuration

The **Configuration > User Accounts** page has the following suboptions:

- [User Accounts Settings \(Password Rules\)](#)
- [Local User Accounts](#)
- [LDAP \(Servers and Users\)](#)
- [Kerberos \(Servers and Users\)](#)

### User Accounts Settings (Password Rules)

**Configuration > User Accounts > User Accounts Settings**

**▲ Password Rules**

Minimum Number Of Characters:

Minimum Number Of Upper Case Alphabetic Characters (A-Z):

Minimum Number Of Lower Case Alphabetic Characters (a-z):

Minimum Number Of Numeric Characters (0-9):

Minimum Number Of Special Characters (!@#\$%^&\*()\_+~=:|{}.'<>?,./):

Maximum Number Of Identical Consecutive Characters:

Maximum Number Of Failed Logins Before Password Is Locked:

Maximum Number Of Days Before Password Must Be Changed:

Number Of Password Changes Before An Old Password Can Be Used Again:

Use the **Configuration > User Accounts > User Accounts Settings** option to set the rules used for passwords. Use the drop-down menus to make your selections and click **Submit**.

### Local User Accounts

**Configuration > User Accounts > Local User Accounts**

NOTE: A maximum of 80 users can be added to the system.

**▲ Local Users**

Name	User Role	Status	Last Activity
administrator	Administrator	Connected	12:03:36 16.03.2018
user	User	Disconnected	09:53:48 15.03.2018

Use the **Configuration > User Accounts > Local User Accounts** option to set the passwords for up to 80 user or administrator accounts.

- **User** – This account allows access to only the library status information and does not allow access to configuration, maintenance, or operation features. A password is not required for the user account. Setting a user password restricts access to even the status information. The library initially has no User password.
- **Administrator** – Setting an administrator password provides restricted access to the administrator functions of the RMI. The library initially has a default administrator password **adm001**. The administrator password can only be changed from the RMI.

To create a new user account, click the **Add User +** button. From the drop-down menu, select the user type and then enter and confirm the new password in the blank fields. The password must contain 8-16 characters, which can include upper- and lower-case letters, numbers, and special characters.

Highlight a user in the list and use the **Actions** drop-down menu to modify a password, change role permissions for magazines and mailslots, change an OCP PIN, or remove an existing user other than the basic User and Administrator.

### LDAP (Servers and Users)

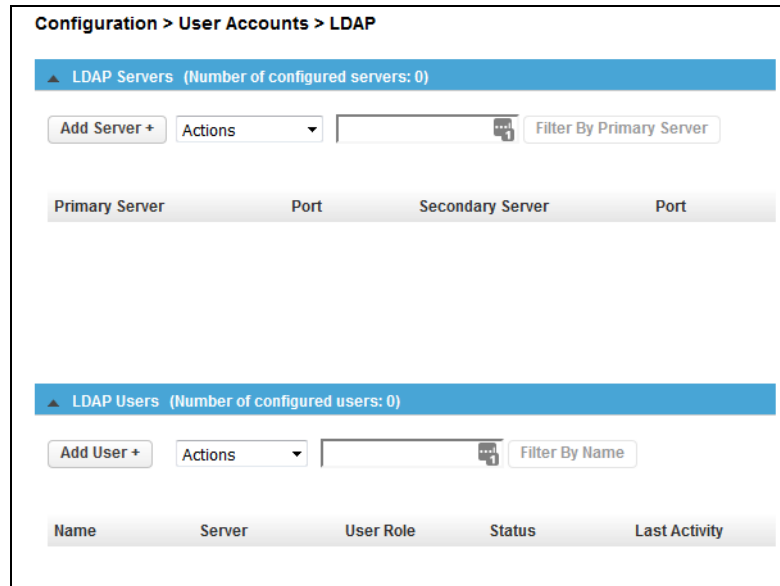

Use the **Configuration > User Accounts > LDAP** option to configure LDAP servers and users. To create a new LDAP account, click either the **Add Server +** or **Add User +** button. A pop-up window appears.

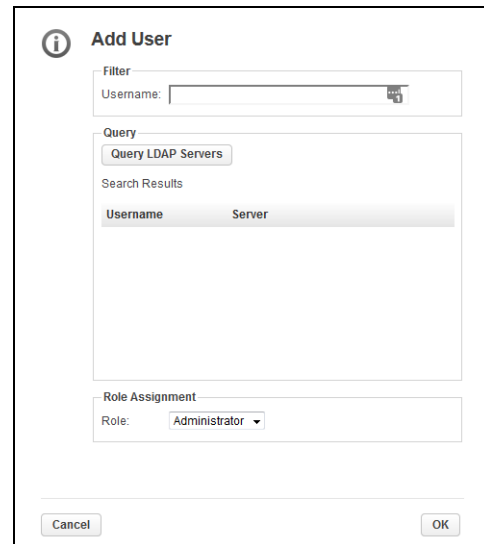
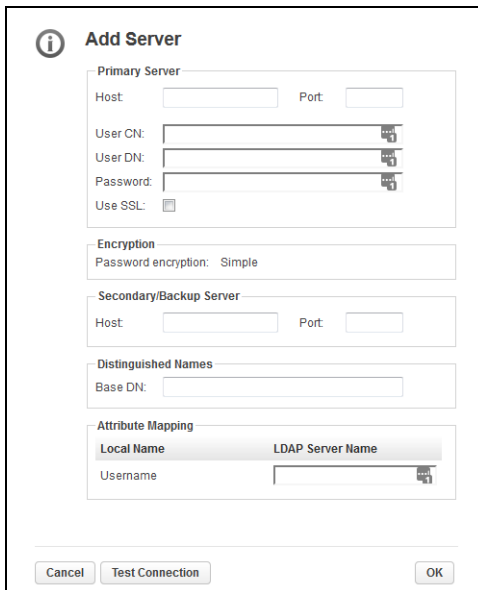

Fill in the fields as appropriate and click **OK**. To test the configuration for the server, click **Test Connection**.

On the option page, highlight a server or user in the lists and use the **Actions** drop-down menu to modify or remove the server/user.

For very long lists, you can enter a partial name in the search field and click **Filter By Name**. Wildcards are not supported.



### Kerberos (Servers and Users)

Use the **Configuration > User Accounts > Kerberos** option to configure Kerberos servers and users.

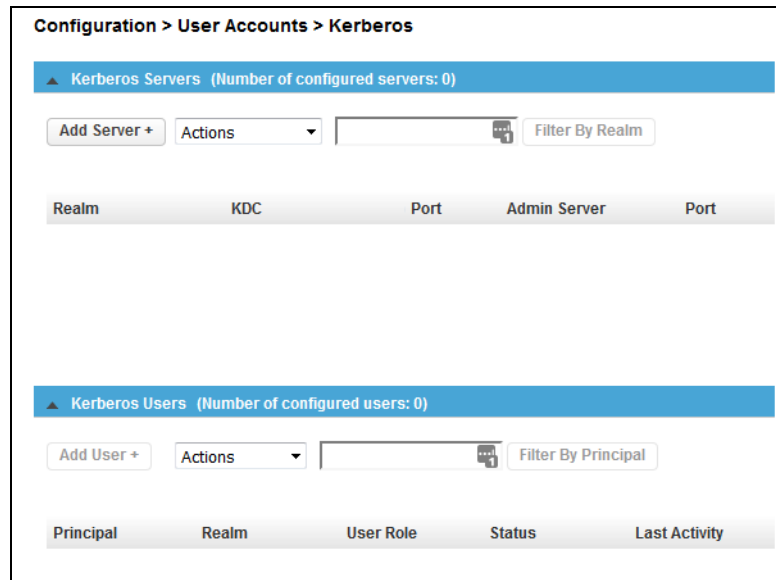

### Web Management Configuration

This option covers SSL/TLS connections, session controls, and RMI login restrictions.

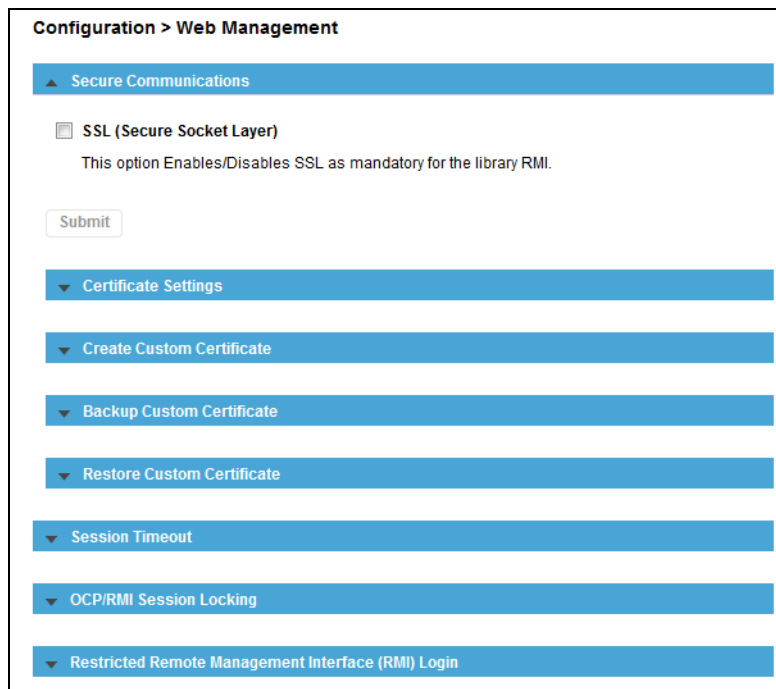

Use the **Configuration > Web Management** page to configure these items:

- [Secure Communications](#)
  - [Certificate Settings](#)
  - [Create Custom Certificate](#)

- [Backup Custom Certificate](#)
- [Restore Custom Certificate](#)
- [Session Timeout](#)
- [OCP/RMI Session Locking](#)
- [Restricted Remote Management Interface \(RMI\) Login](#)

### Secure Communications

Enable or disable secure access to the RMI using Secure Socket Layer (SSL) from the **Configuration > Web Management** page under the **Secure Communications** option bar. When SSL is enabled, connections to the RMI must use HTTPS. The default is disabled.

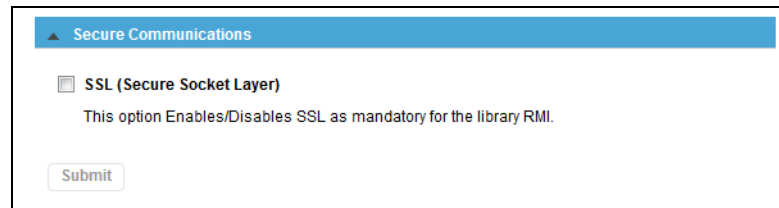

The screenshot shows a configuration panel titled "Secure Communications". It contains a checkbox labeled "SSL (Secure Socket Layer)" which is currently unchecked. Below the checkbox is a descriptive text: "This option Enables/Disables SSL as mandatory for the library RMI." At the bottom of the panel is a "Submit" button.

### Certificate Settings

This option allows you to switch between a self-signed certificate (system default) and a custom certificate created using a wizard.

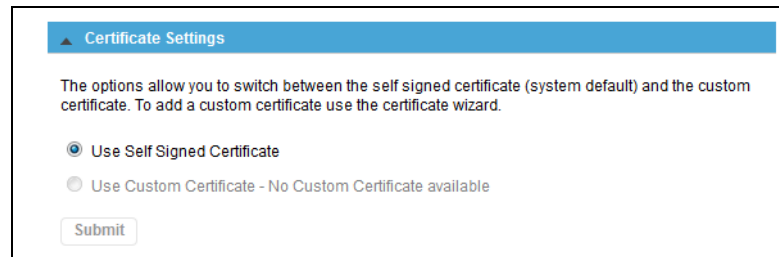

The screenshot shows a configuration panel titled "Certificate Settings". It contains a text block: "The options allow you to switch between the self signed certificate (system default) and the custom certificate. To add a custom certificate use the certificate wizard." Below this are two radio button options: "Use Self Signed Certificate" (which is selected) and "Use Custom Certificate - No Custom Certificate available". At the bottom is a "Submit" button.

### Create Custom Certificate

This option uses a wizard to create a custom certificate. Click the button to start the wizard.

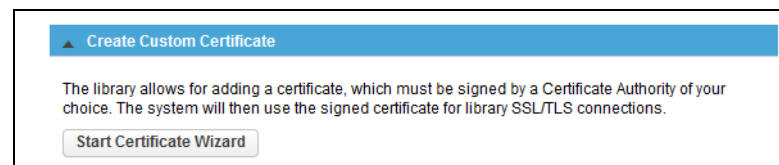

The screenshot shows a configuration panel titled "Create Custom Certificate". It contains a text block: "The library allows for adding a certificate, which must be signed by a Certificate Authority of your choice. The system will then use the signed certificate for library SSL/TLS connections." Below the text is a button labeled "Start Certificate Wizard".

### Backup Custom Certificate

Use the **Backup Custom Certificate** button to download a custom certificate created by the wizard.

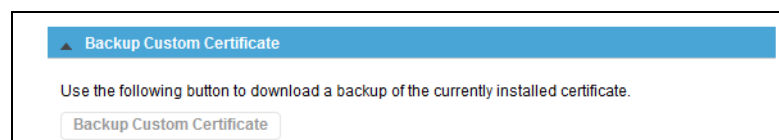

The screenshot shows a configuration panel titled "Backup Custom Certificate". It contains a text block: "Use the following button to download a backup of the currently installed certificate." Below the text is a button labeled "Backup Custom Certificate".

## Restore Custom Certificate

This option to locate and restore a previously saved certificate file.

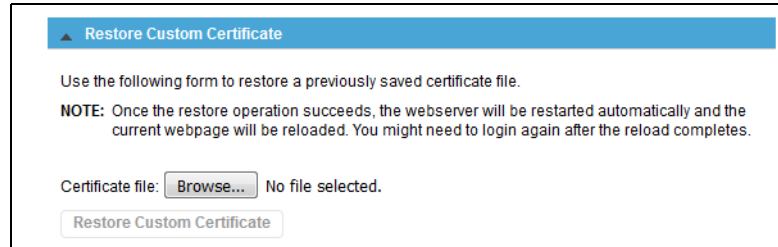

▲ Restore Custom Certificate

Use the following form to restore a previously saved certificate file.

**NOTE:** Once the restore operation succeeds, the webserver will be restarted automatically and the current webpage will be reloaded. You might need to login again after the reload completes.

Certificate file:  No file selected.

Click **Browse** to locate the certificate file and then **Restore Custom Certificate** to restore it.

## Session Timeout

This option determines how long a user can stay inactive before being logged out.

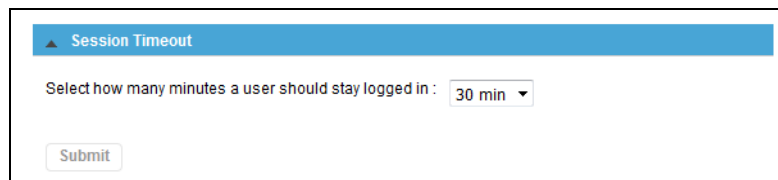

▲ Session Timeout

Select how many minutes a user should stay logged in :

Use the drop-down list to choose a time and click **Submit**.

## OCP/RMI Session Locking

Check the box and click **Submit** to allow only one OCP or RMI session at a time by an Administrator.

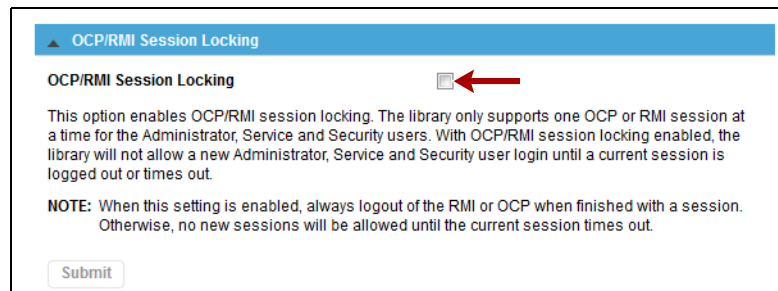

▲ OCP/RMI Session Locking

OCP/RMI Session Locking  ←

This option enables OCP/RMI session locking. The library only supports one OCP or RMI session at a time for the Administrator, Service and Security users. With OCP/RMI session locking enabled, the library will not allow a new Administrator, Service and Security user login until a current session is logged out or times out.

**NOTE:** When this setting is enabled, always logout of the RMI or OCP when finished with a session. Otherwise, no new sessions will be allowed until the current session times out.

## Restricted Remove Management Interface (RMI) Login

The Administrator can set login restrictions for Administrator and Security login. If restriction mode is enabled, the Administrator and Security are not allowed to login via RMI. The Administrator has to disable the restriction mode by logging into the OCP and changing the setting there.

Only the Administrator is allowed to set and reset the restricted RMI login.

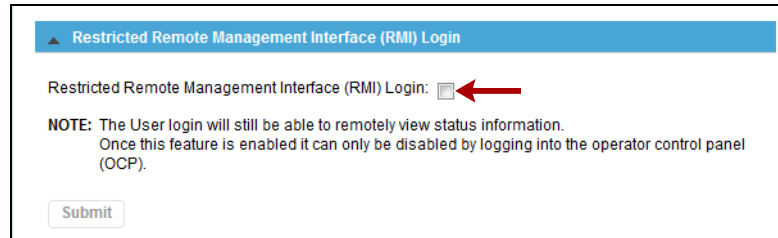

Restricted Remote Management Interface (RMI) Login

Restricted Remote Management Interface (RMI) Login:

**NOTE:** The User login will still be able to remotely view status information. Once this feature is enabled it can only be disabled by logging into the operator control panel (OCP).

Submit

Check the box and click **Submit**.

## RMI Maintenance Options



From the **Home** page, click **Maintenance** to access the library maintenance features:

- [Library Tests](#)
- [View Logs and Traces](#)
- [Firmware Upgrades](#)
- [Download Drive Logs](#)
- [System Reboot](#)
- [Drive Reboot](#)
- [UID LED Control](#)
- [Move Robotic to Base Module](#)

### Library Tests

The **Maintenance > Library Tests** page has the following options:

- [System Test](#)
- [Slot-to-Slot Test](#)
- [Element-to-Element Test](#)
- [Position Test](#)
- [Wellness Test](#)
- [Robotic Test](#)
- [OCP Test \(with LCD Adjustment Reset\)](#)



## Element-to-Element Test

The **Element-To-Element Test** moves a selected cartridge to a selected slot or tape drive, and then returns it to the original slot. It is intended to show that the library is operating correctly.

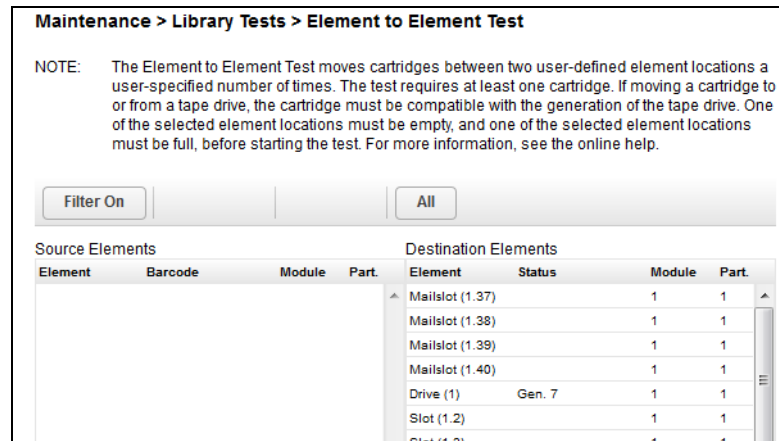

- One element must contain a cartridge and the other must be empty.
- You can select the number of times to move the selected cartridge to the destination location and back.
- If a tape is moved to an incompatibly drive, the drive will reject the tape, as designed.
- During the test the library is offline.

**NOTE:** To diagnose problems with the Robotic Assembly or verify that it has been correctly replaced, use the [Robotic Test](#) (see [Robotic Test](#) on page 103).

To run the test:

1. Navigate to the **Maintenance > Library Tests > Element-to-Element Test** page.
2. Select a cartridge from the **Source Elements** list.  
To select from a **subset** of the cartridges, click **Filter On**, enter barcode label characters into the search box, and then click **Search**. The **Source Elements** list is updated to only include cartridges with a barcode label including the search characters.
3. Select an empty location from the **Destination Elements** list.
4. Select the **number** of cycles.
5. Click the **Start Test** button that appears.

## Position Test

The **Position Test** moves the Robotic Assembly **vertically** between two element locations. The test does not move cartridges. The test is intended to show that the vertical movement of the Robotic Assembly is operating correctly.

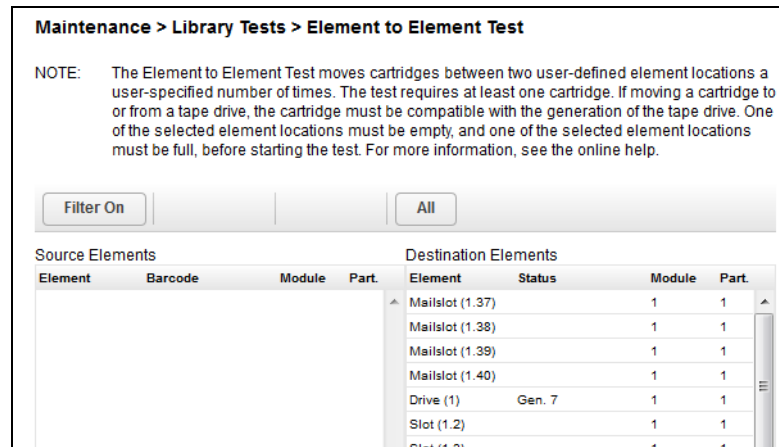

- You can select the number of times to move the Robotic Assembly between two element positions.
- During the test the library is offline.

**NOTE:** To diagnose problems with the Robotic Assembly itself or verify that it has been correctly replaced, use the Robotic Test (see [Robotic Test on page 103](#)).

To run the test:

1. Navigate to the **Maintenance > Library Tests > Position Test** page.
2. Select a source location from the **Source Elements** list.
3. Select a destination location from the **Destination Elements** list.
4. Select the **number** of cycles.
5. Click the **Start Test** button that appears.

### Wellness Test

The **Wellness Test** exercises a general health check on library functionality by running the following partial tests:

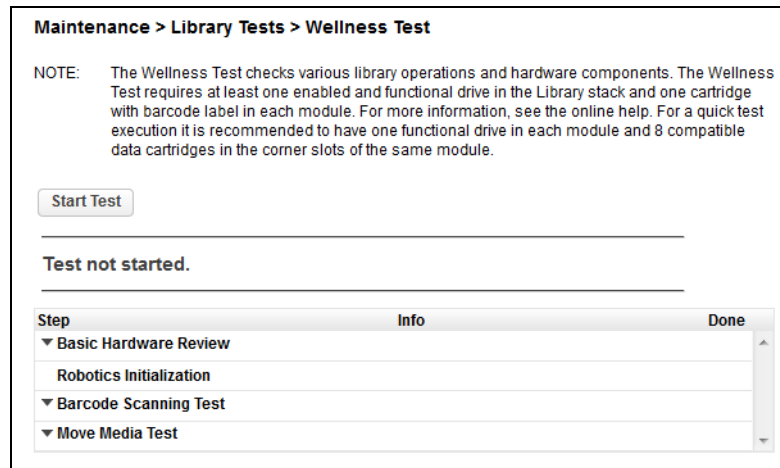

- Basic Hardware Review
- Robotics Initialization Test
- Barcode Scanning Test
- Move Media Test

Running the test requires **each module** to have:

- At least one enabled and functional drive
- One cartridge with a barcode label

After the test has been started, the **Stop Test** button is active. Clicking the button aborts the **Wellness Test** but not before the current partial test has been completed.

- The test operates over the whole library and does not take into account partition configuration.
- During the test the library is offline.

The **Info** column notifies the user about the status and result of each partial test.

To run the test, navigate to the **Maintenance > Library Tests > Wellness Test** page, and then click **Start Test**.

**Tip:** For quickest test execution, it is recommended to have one functional drive in each module and eight compatible cartridges in the corner slots of the same module.

### Robotic Test

The **Robotic Test** exercises all Robotic Assembly movements and sensors. During the test the library is offline.

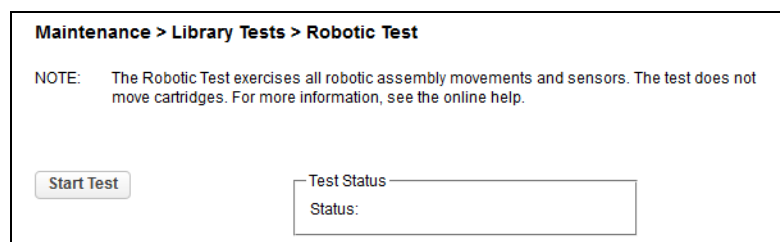



To run the test, navigate to the **Maintenance > Library Tests > Robotic Test** page, then click **Start Test**.

### OCP Test (with LCD Adjustment Reset)

The **Maintenance > Library Tests > OCP Test** exercises functionality of the front panel LEDs or resets the contrast and brightness of the OCP LCD display.

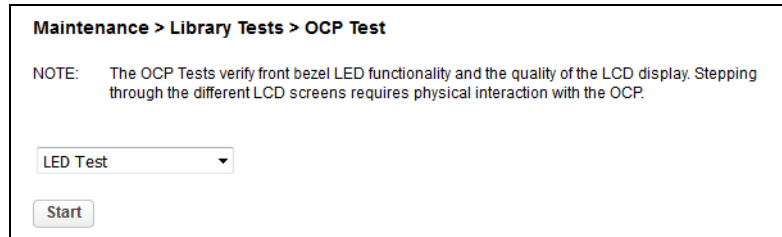

To start a test/reset, select it from the drop-down menu, and click **Start**.

- **LED Test** – Switches every LED on/off sequentially left to right and right to left. During the test, the library is offline.
- **Reset LCD Adjustment** – Resets the OCP LCD contrast and brightness back to the defaults (50% and 100%).

## View Logs and Traces

Logs are created for every event, information alert, and configuration change.

The **Maintenance > View Logs and Traces** page has the following options:

- [View Logs](#)
- [Download Logs and Traces](#)

### View Logs

To view the library log files, navigate to the **Maintenance > Logs and Traces > View Logs** page and then select one of the logs. Use the drop-down menu on the right to choose a table of available logs. Click a row in the table to view the log.

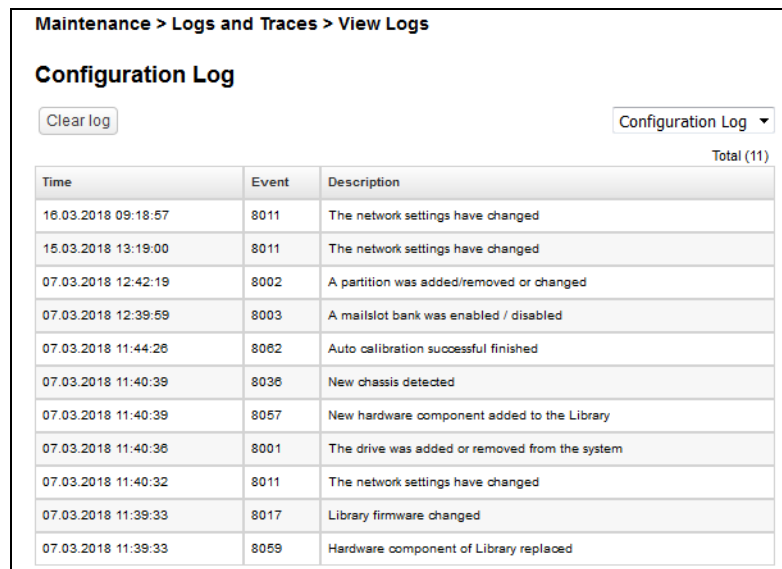

Available log types are:

- **Event Ticket Log** – Records library error and warning events.
- **Information Log** – Records library information warnings.
- **Configuration Log** – Records configuration changes.
- **Show All** – The three types of logs are listed in the table.

The log entries are displayed in order of most recent to oldest. The log entries contain a ticket number, date and time code, event code, description, current event state, component type, component identifier, and severity. The format for the date and time code is:

**DD.MM.YYYY** (Day . Month . Full\_Year)  
**HH.MM.SS** (Hour . Minute . Second)

## Download Logs and Traces

**NOTE:** Users and Administrators should download support tickets instead of log and trace files because the support ticket will have complete information about each library event and is easier to read. See [Download Drive Logs](#) on page 107.

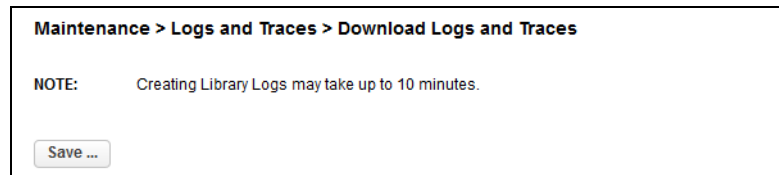

To download the library log and trace files from the RMI, navigate to the **Maintenance > Logs and Traces > Download Logs and Traces** page and then click **Save**.

## Firmware Upgrades

Library and drive firmware can be upgraded to the latest version. Customization of the library is also available from this page.

The **Maintenance > Firmware Upgrades** page has the following options:

- [System Firmware Upgrade](#)
- [Drive Firmware Upgrade](#)

### System Firmware Upgrade

The firmware version currently installed on the library is displayed in the library status area on the upper left corner of the **Home** page. You update the library firmware from the **Maintenance > Firmware Upgrades > System Firmware** page.

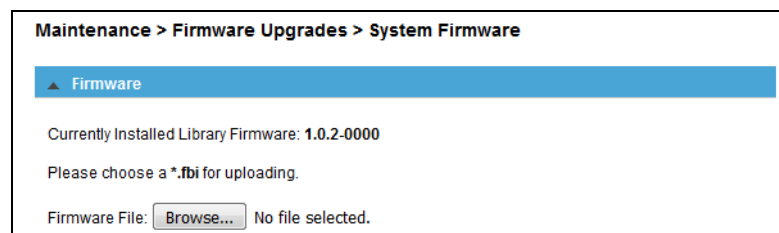

To update library firmware with the RMI, click **Browse** and select the firmware file (.fbi) from the local computer. Click **Start Upgrade**.

**NOTE:** When you update the library firmware, the library also updates the firmware of the expansion modules to a compatible version.

### Drive Firmware Upgrade

Drive firmware can be updated on multiple drives of the same type at the same time. Drive firmware can only be updated with the RMI. Each drive only accepts the appropriate firmware for that type of drive.

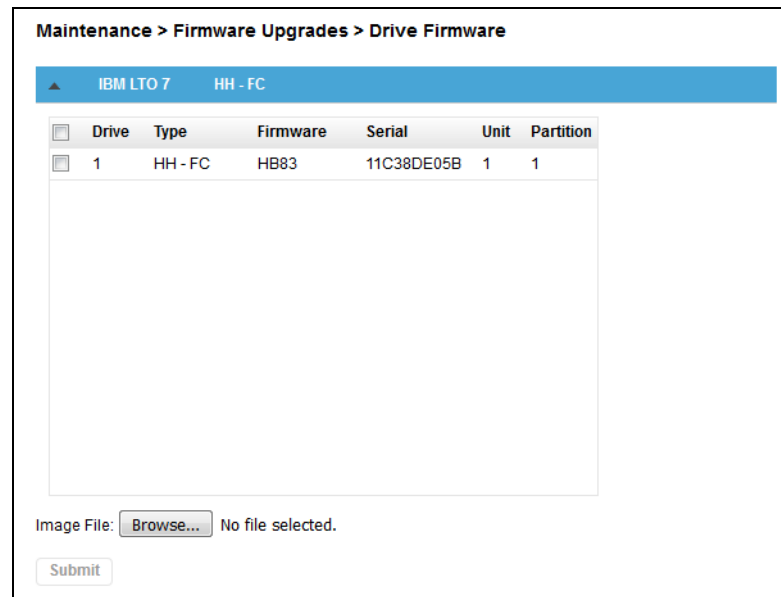

To see the firmware version currently installed on the drives, navigate to the **Maintenance > Firmware Upgrades > Drive Firmware** page.

To update drive firmware with the RMI:

1. Navigate to the **Maintenance > Software Upgrades > Drive Firmware** page. The tape drives are organized by drive type.
2. Expand the appropriate drive type option and select one or more of the **tape drives**. Click the box in the title bar to select all drives of that type.
3. Click **Choose File**, and then select the **FMRZ file** from the local computer.
4. Click **Submit**.

## Download Drive Logs

From the **Maintenance > Download Drive Logs** page you can download a support ticket from the library or any of the tape drives.

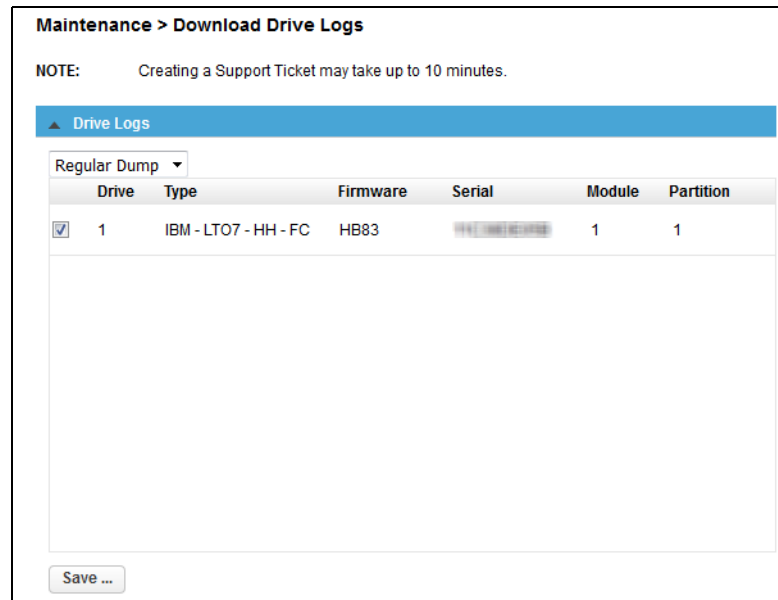

To download a drive log:

1. If necessary, expand the **Drive Logs** list by clicking the option bar.

The list displays:

- **Drive** – The drive number. Drives are numbered starting with the one at the physical bottom of the library up to the top.
- **Type** – The drive manufacturer, LTO version, form factor (half height or full height), and interface (FC or SAS).
- **Firmware** – The current drive firmware version number.
- **Serial** – The drive serial number.
- **Module** – The module containing the tape drive.
- **Partition** – The logical library associated with the tape drive.

2. Select a **drive** by checking the box next to it.

3. Select the **log** (DMP file) to download:

- **Regular Dump** – This option downloads a regular dump file for the tape drive.
- **Forced Dump** – This option downloads a forced dump file for the tape drive.
- **Dump to Flash** – The log is stored in the flash memory of the library.

4. Click **Save**.

The process may take up to 10 minutes. When a regular or forced dump is done, the creation message is displays **Download** and **Cancel** buttons.

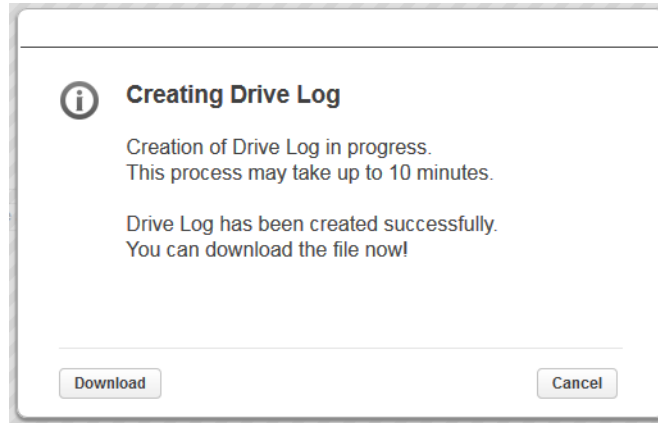

**NOTE:** A **Dump to Flash** log is automatically downloaded and the message cleared.

5. For a regular or forced dump, click **Download** and select whether to open or save it.

## System Reboot

To reboot the library with the RMI, navigate to the **Maintenance > System Reboot** page and then click **Reboot**.

## Drive Reboot

**NOTE:** Only one drive at a time can be selected for rebooting.

To reboot a drive with the RMI, navigate to the **Maintenance > Drive Reboot** page.

1. From the list, select the **drive** you want to reboot.
2. Click **Submit**.
3. At the confirmation message, click **Yes** to start the reboot.

## UID LED Control

UID (Unit Identification) LEDs refers to the blue LEDs on the tape library that assist users and Service personnel in determining which component requires attention.

There one LED on the rear of each of the module controllers of the NEOxl 40 Tape Library.

**NOTE:** Additionally there is one UID LED on the OCP front panel. Control of this LED is linked to the Base controller's UID LED. If the Base controller is selected and its UID LED is switched on, the OCP UID LED is switched on as well.

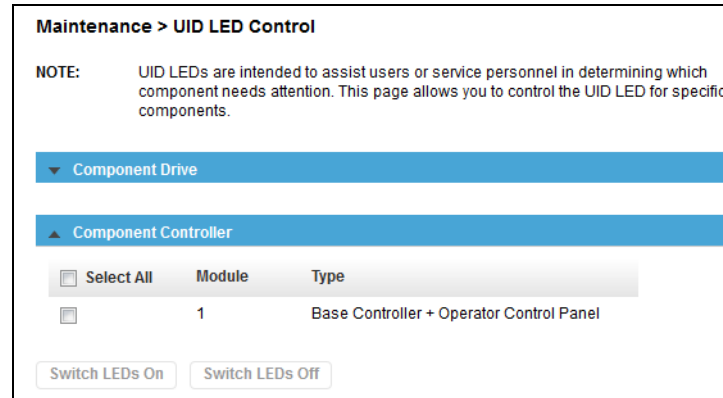

To select and switch on the UID LEDs, navigate to the **Maintenance > UID LED Control** page.

1. Select the **components** where you want to switch on the UID LEDs.
2. Click **Switch LEDs On**.
3. When done, click **Switch LEDs Off**.

## Move Robotic to Base Module

Before extending a module from the rack, the Robotic Assembly must return to its park position in the Base Module. Under normal circumstances, when the library is powered off using the front power button, the robot automatically parks and locks in the Base Module behind the OCP.



**CAUTION:** After powering off the library and before proceeding with extending a module from the rack, look inside the upper or lower expansion module window to verify that the Robotic Assembly is behind the OCP.

If the library did not move the Robotic Assembly to its park position, you can do so from the **Maintenance > Move Robotic to Base Module** page.

## Support Information

The **Maintenance > Support Information** page shows how to obtain technical support either online or via telephone.

## RMI Operation Options

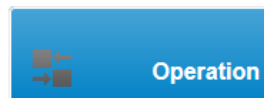

Click **Operation** on the **Home** page to access the RMI library operations features.

- [Moving Media](#)
- [Open Mailslot](#)
- [Open a Magazine](#)
- [Clean a Tape Drive](#)
- [Rescan Cartridge Inventory](#)

- [Force a Drive to Eject a Cartridge](#)

## Moving Media

From the **Operation > Move Media** page you can move a tape cartridge located in a source element to an available destination element within the same partition.

**Operation > Move Media**

Barcode Filter On  Search

Source Elements				Destination Elements			
Element	Barcode	Mod.	Part.	Element	Status	Mod.	Part.
Mailslot (1.37)	AE0513L7	1	1 (101)	Mailslot (1.38)		1	1 (102)
Mailslot (1.39)	BHW921L7	1	1 (103)	Drive (1)	Gen. 7	1	1 (1)
Mailslot (1.40)	CLN549L7	1	1 (104)	Slot (1.2)		1	1 (1001)
				Slot (1.3)		1	1 (1002)
				Slot (1.4)		1	1 (1003)
				Slot (1.5)		1	1 (1004)
				Slot (1.7)		1	1 (1005)
				Slot (1.8)		1	1 (1006)
				Slot (1.9)		1	1 (1007)
				Slot (1.10)		1	1 (1008)
				Slot (1.12)		1	1 (1009)
				Slot (1.13)		1	1 (1010)
				Slot (1.14)		1	1 (1011)
				Slot (1.15)		1	1 (1012)
				Slot (1.17)		1	1 (1013)
				Slot (1.18)		1	1 (1014)

Move Source: Mailslot (1.37) to Destination: Drive (1)

- **Source Elements** – Tape drives, enabled mailslots, and storage slots that contain a tape cartridge.
- **Destination Elements** – Tape drives, enabled mailslots, and storage slots that do not contain a tape cartridge.

Element list organization is as follows:

- Mailslots are listed first in the order of the mailslot numbers. Mailslots are numbered *m.s*, where *m* is the module number and *s* is the mailslot within the module.
- Tape drives are listed next and in the order of their drive numbers. Tape drives are numbered from the physical top of the library starting with **Drive (1)**.
- Slots are listed in the order of the slot numbers. Slots are numbered *m.s*, where *m* is the module number and *s* is the slot within the module.

### Filtering Based on Barcode

To see a subset of the cartridges in the library, with the **Barcode Filter On** (default), enter some or all of the barcode label characters in the search field and click **Search**. The **Source Elements** list updates to display only the cartridges with labels that include the characters in the search box.

To perform a different search or display all of the available cartridges, click **Barcode Filter Off**.

### Moving a Cartridge

1. Select the **cartridge** from **Source Elements**.
2. Select the **destination** location from **Destination Elements**.

3. Click **Submit**.

A move message is displayed. When done, the source list updates to show the new location of the cartridge and the destination list updates to show the previous location as empty and available.

### Open Mailslot

From the **Operation > Open Mailslot** page you can see the status of and unlock any enabled mailslot in the library.

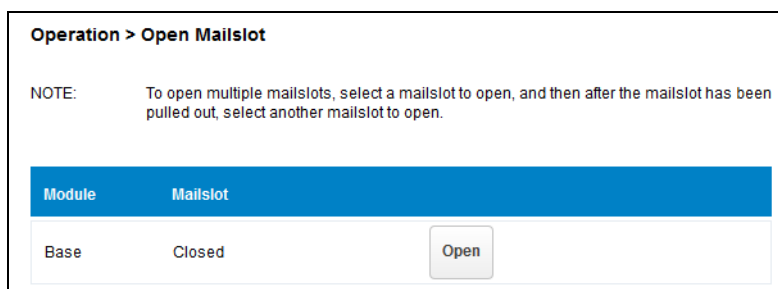

To open a mailslot, click **Open** for the appropriate mailslot. The library releases the lock and you can then pull the mailslot out of the library to access it.

**NOTE:** The mailslot relocks after 30 seconds if it is not opened.

For information about manually opening a mailslot, see [Manual Tape Magazine Access](#).

The mailslot must be enabled before it can be opened. To enable a mailslot, see [Mailslot Configuration on page 88](#).

### Open a Magazine

From the **Operation > Open Magazine** page you can unlock any magazine in the library.

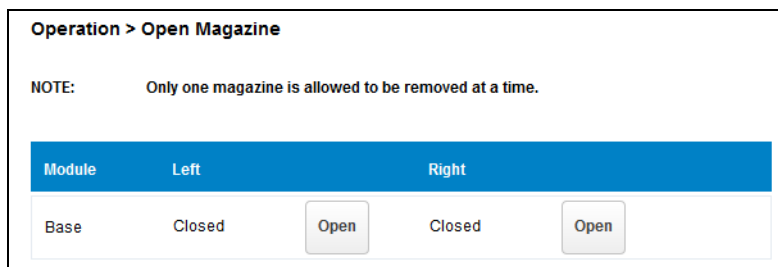

To unlock a magazine, click **Open** for the magazine. The library releases the lock. You can then pull the magazine out of the library to access the storage slots.

**NOTE:** Opening a magazine takes the library offline. The magazines relock after 30 seconds if not opened.

For information about manually opening a magazine, see [Manual Tape Magazine Access](#).



## Clean a Tape Drive

From the **Operation > Clean Drive** page you can initiate a drive cleaning operation.

Source Elements					Destination Elements		
Element	Barcode	Mod.	Part.	Use #	Element	Status	Mod. Part.
Mailslot (1.40)	CLN549L7	1	1 (104)	N/A	Drive (1)		1 (1)

Move Source: Mailslot (1.40) to Destination: Drive (1)

1. Select a **cleaning cartridge** from the **Source Elements** list. The library uses the barcode label (CLNxxxxx) to identify cleaning cartridges.  
If no cleaning cartridges are available, load one into a mailslot or magazine slot.
2. Select the **tape drive** to be cleaned from the **Destination Elements** list.  
Tape drives currently containing a cartridge are not listed. To clean a tape drive not listed, move the cartridge out of the drive.
3. Click **Submit**.

## Rescan Cartridge Inventory

To have the library rescan the cartridges, navigate to the **Operation > Rescan Inventory** page and click **Rescan**. The library changes to Scanning (Offline) status and is unavailable to perform other operations until the scan is complete.

**Operation > Rescan Inventory**

NOTE: Rescan inventory can take several minutes to complete.

## Force a Drive to Eject a Cartridge

The **Force Drive Media Eject** operation attempts to force the tape drive to eject the cartridge and place it into an open slot. Access to this feature requires the administrator password.

Before performing this option, it is recommended that you attempt to eject the tape using the backup software or library **Move Media** operation. While a drive is being force ejected, a window indicating the process is ongoing should appear. No operations are available until the force eject completes.

**NOTE:** If the drive has difficulty ejecting the cartridge, the media is possibly bad or damaged.

1. Navigate to the **Operation > Force Drive Media Eject** page.
2. Select the **drive** in the **Source Elements** list.
3. Select the **destination** in the **Destination Elements** list.
4. Click **Submit**.

## RMI Status Options



Click **Status** on the **Home** page to access the RMI library statuses.

- [Library and Module Status](#)
- [Cartridge Inventory Views](#)
- [Partition Map Views](#)
- [Drive Status](#)
- [Network Status](#)

### Library and Module Status

Summary information and status is displayed in the Top Banner and the Left Pane. For additional library module configuration and status information navigate to the **Status > Library Status** page.

There are three areas on this page:

- [Library Information](#)
- [Library Status](#)
- [Module Status](#)

### Library Information

If necessary, click the option bar to view the following items listed in this section.

**Status > Library Status**

▲ Library Information

Vendor:	<b>BDT</b>	Product ID:	<b>MULTISTAK</b>
Serial Number:	<b>DE56400017</b>		
Base Firmware Revision:	<b>1.0.2-0000</b>	Expansion Firmware Revision:	<b>0.29</b>
Robotic Hardware Revision:	<b>4</b>	Robotic Firmware Revision:	<b>0.11</b>
Barcode Reader Hardware Revision:	<b>SE-625</b>	Barcode Reader Firmware Revision:	<b>PAAAMC00-002-N09D0</b>

▼ Library Status

▼ Module 1 (Base)

Refresh

- **Vendor**
- **Serial Number** – Library serial number
- **Base Firmware Revision** – Version of the currently installed library firmware.
- **Robotic Hardware Revision**
- **Barcode Reader Hardware Revision**
- **Product ID**
- **Expansion Firmware Revision**
- **Robotic Firmware Revision** – Version of the currently installed Robotic Assembly firmware. The Robotic Assembly firmware is bundled and installed with the library firmware.
- **Barcode Reader Firmware Revision** – Version of the currently installed barcode reader firmware. The barcode reader firmware is bundled and installed with the library firmware.

### Library Status

If necessary, click the option bar to view the following items listed in this section.

**Status > Library Status**

▼ Library Information

▲ Library Status

Library Status:	<b>Idle</b>	Total Power On Time:	<b>12d 0h 24m</b>
Cartridge in Transport:	<b>None</b>	Odometer:	<b>4</b>
Robotic Location:	<b>Module 1 (Base)</b>	Shipping Lock:	<b>Unlocked</b>

▼ Module 1 (Base)

Refresh

- **Library Status** (matches the status in the **Top Banner**)
  - **Idle** – The library robotic is ready to perform an action.
  - **Moving** – The library robotic is moving a cartridge.
  - **Scanning** – The library robotic is performing an inventory of cartridges.

- **Offline** – The library robotic has been taken offline by the library.
- **Cartridge in Transport** – When applicable, displays the barcode label of the cartridge currently in the Robotic Assembly.
- **Robotic Location** – Displays the module where the robotic is currently located.
- **Total Power On Time** – Total time that the Base Module has been powered on since it was manufactured.
- **Odometer** – Robotic assembly move count.
- **Shipping Lock** – Indicates whether the robotic is unlocked or locked for shipment

### Module Status

If necessary, click the option bar to view the following items listed in this section.

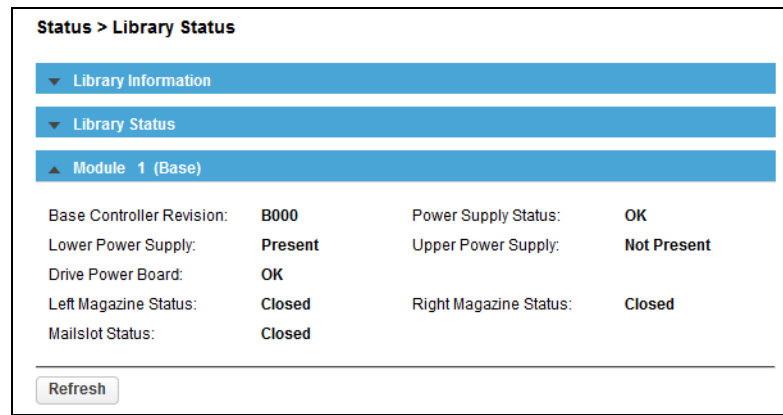

- **Base/Expansion Controller Revision** – Hardware revision of the controller board currently installed in the module.
- **Lower Power Supply** – Displays the presence status of the power supply in the lower bay.
- **Drive Power Board** – Status of the Drive Power Board (DC-DC converter) for the three half-height drive slots in the module.
- **Left Magazine Status** – Shows either **Open** or **Closed**.
- **Mailslot Status** – Shows **Open**, **Closed**, or **Disabled** - mailslot cannot be opened.
- **Power Supply Status** – Displays the status of power redundancy.
- **Upper Power Supply** – Displays the presence status of the power supply in the lower bay.
- **Right Magazine Status** – Shows either **Open** or **Closed**.

You can click **Refresh** to update the statuses.

### Cartridge Inventory Views

To see the library elements organized by module, from **Status**, navigate to **Cartridge Inventory**. From there, select either a listing or a graphical view of elements. Both inventory view options display each of the elements, such as slots and tape drives, with information about any cartridge stored in the element.

**NOTE:** Cartridges stored in unused slots, which are not available for move operations, are grayed out and are not assigned to any partition.

There are the different types of views:

- [Cartridge Graphical View](#)
- [Cartridge List View](#)

### Cartridge Graphical View

The inventory graphical view displays each of the elements, such as slots and tape drives, with information about the cartridge stored in the element broken out by module.

**NOTE:** Unused slots, which are not available for move operations, are grayed out and marked with a cross. Any cartridges stored in these slots are displayed in the same way as regular slots.

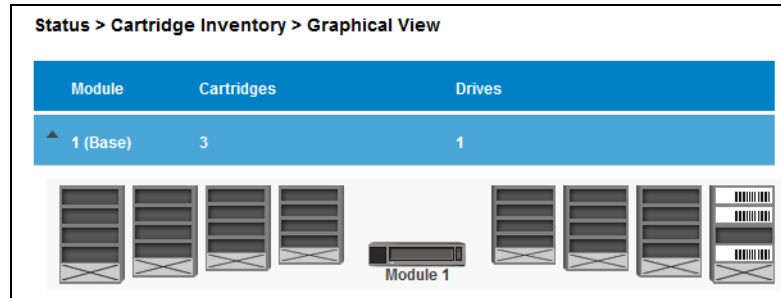

Moving the mouse over a drive or cartridge image displays additional information.

- Drives:

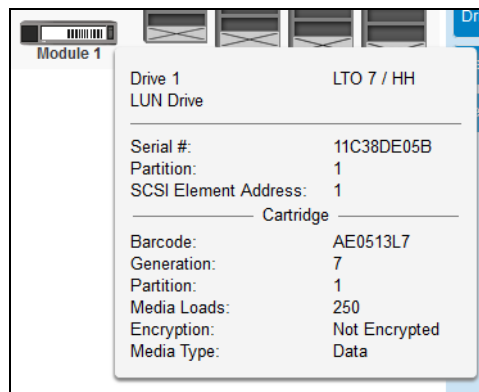

The top area shows the drive number, drive type, and drive details (LTO generation / form factor).

The center area shows the serial number of the drive, the partition number, and the SCSI element address.

If a cartridge is in the drive, the bottom area shows the barcode, LTO generation, partition it originated from, the number of times it has been loaded, and the type of cartridge (data or cleaning).

- Slots:

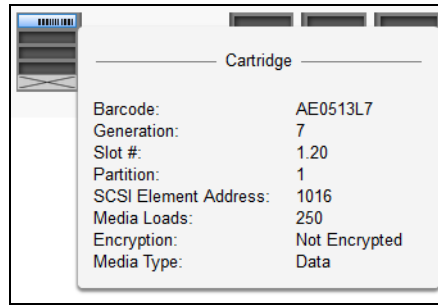

If a cartridge is in the slot, when clicked, a pop-up shows the barcode, LTO generation, the slot number in the form *m.s* (where *m* is the module number and *s* is the slot number), partition in which it is located, the number of times it has been loaded, if the data is encrypted, and the type of cartridge (data or cleaning).

Warning and error states for a specific drive or cartridge are indicated with icons.

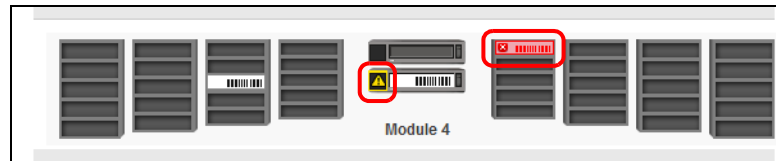

### Cartridge List View

To see a list of the elements organized by module, navigate to **Status > Cartridge Inventory > List View**. The default view is one of all the slot elements.

Status > Cartridge Inventory > List View

Drives Cartridges Group Off

Filter On

Module	Slot #	Barcode	Full	Gen.	Partition
▲ 1					
	1.1				
	1.2				1 (1001)
	1.3	AE0513L7	X	7	1 (1002)
	1.4				1 (1003)
	1.5				1 (1004)
	1.6				
	1.7				1 (1005)
	1.8				1 (1006)
	1.9				1 (1007)

The List View displays:

- **Module** – The module number.
- **Slot #** – The slot number in the form *m.s* (where *m* is the module number and *s* is the slot number). A number in the form D (#) is for a drive number.
- **Barcode** – The barcode label (if any).
- **Full** – **X** if a cartridge is in the slot.
- **Gen.** – LTO generation of the cartridge.
- **Partition** – The partition number.

**NOTE:** Cartridges stored in unused slots, which are not available for move operations, are grayed out and are not assigned to any partition.

The buttons at the top can filter the display.

**Listing Based on Slots or Drives.** To limit the list to just tape drives, click **Drives**. Only the drive elements are show and the button changes to **Slots**. To return to the default slots view, click **Slots**.

**Listing Filtered by Cartridges.** To limit the list to just cartridges in library elements, click **Cartridges**. To return to a full list of the elements, empty or full, click **Elements**.

**Viewing by Group.** When **Group On** is clicked, the list is grouped by module. You can expand or contract the list for each group by clicking the triangle next to the module number in the first column. To disable grouping, click **Group Off**.

**Filtering by Barcode Label.** To filter the list based on barcode label, click **Filter On** to display the Search field, enter characters in the Search field, and click **Search**. The characters can be anywhere in the barcode label. The search characters are not case sensitive. There are no wildcards. To disable filtering and show all the slots, click **Filter Off**.

## Partition Map Views

To see the elements organized by module, from **Status**, navigate to **Partition Map**. From there, select either a listing or a graphical view of elements. Both inventory view options display each of the elements, such as slots and tape drives, with information about any cartridge stored in the element.

**NOTE:** Cartridges stored in unused slots, which are not available for move operations, are grayed out and are not assigned to any partition.

A third option shows the configuration status of each partition.

### Partition List View

To see a list of the elements organized by partition, navigate to **Status > Partition Map > List View**.

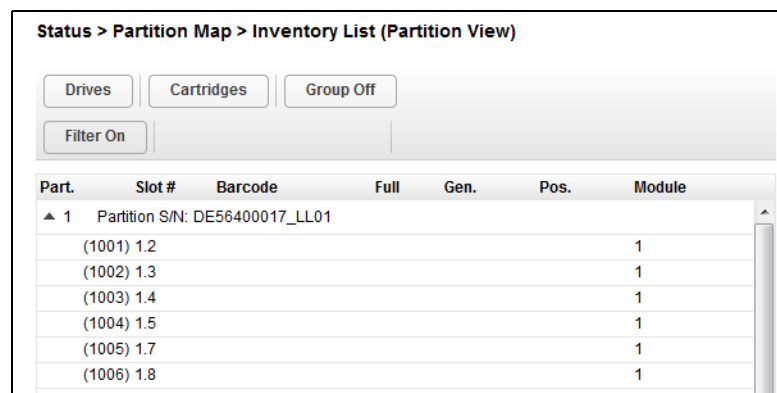

The screenshot shows the 'Status > Partition Map > Inventory List (Partition View)' interface. At the top, there are three buttons: 'Drives', 'Cartridges', and 'Group Off'. Below these is a 'Filter On' button and a search input field. The main content is a table with the following columns: Part., Slot #, Barcode, Full, Gen., Pos., and Module. The table is expanded to show a partition with S/N: DE56400017\_LL01. The rows under this partition are:

Part.	Slot #	Barcode	Full	Gen.	Pos.	Module
▲ 1	Partition S/N: DE56400017_LL01					
	(1001)	1.2				1
	(1002)	1.3				1
	(1003)	1.4				1
	(1004)	1.5				1
	(1005)	1.7				1
	(1006)	1.8				1
	(1007)	1.9				1

The layout and features are the same as for [Cartridge List View on page 117](#). The Groups are by partition instead of module.

## Partition Graphical View

The inventory graphical view displays each of the elements, such as slots and tape drives, with information about the cartridge stored in the element broken out by partition.

**NOTE:** Unused slots, which are not available for move operations, are grayed out and marked with a cross. Any cartridges stored in these slots are displayed in the same way as regular slots.

The graphical view of the partition map displays the partition number for every magazine. In the example below, Magazine #8, which can be configured as mailslot magazine, displays single slots. When they are configured as mailslots, the slot number gets a leading 'M'.

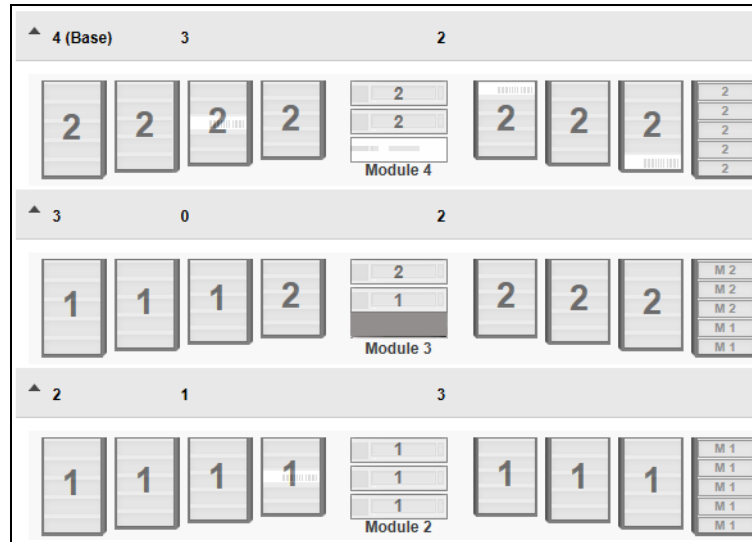

Moving the mouse over a partition layer displays additional information:

- **Name** – Partition name.
- **Barcode** – The barcode orientation.
- **Media Removal** – Indicates whether media removal is allowed or prevented by the host.
- **Key Manager Type** – Encryption type.
- **Partition S/N** – Serial number of the partition.
- **Drive Count** – Number of drives in this partition.
- **Slot Count** – Number of slots in this partition.
- **Cartridge Count** – Number of cartridges in this partition.
- **Mailslot Count** – Number of mailslots in this partition.



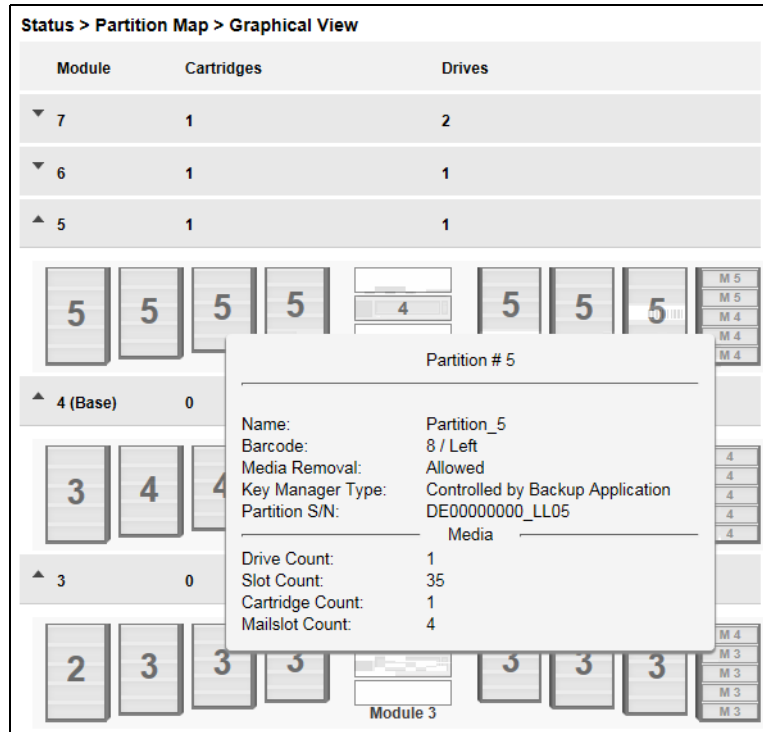

Moving the mouse over a drive or cartridge displays additional information in a pop-up. This is the same as for [Cartridge List View on page 117](#).

### Partition Configuration Status

To see the configuration of a partition, the elements and their status, navigate to **Status > Partition Map > Configuration Status**.

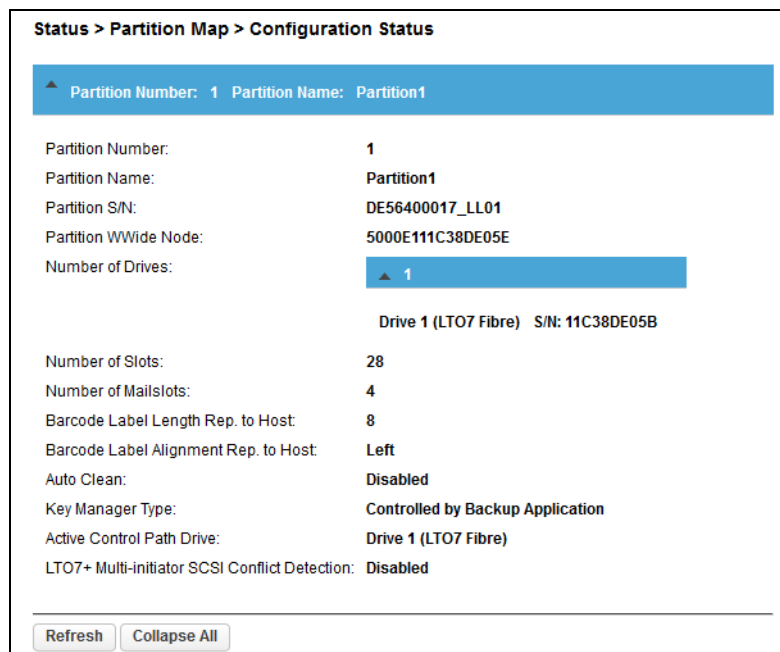

The configuration status list shows:

- **Partition Number** – The partition number.

- **Partition Name** – The partition name.
- **Partition S/N** – The partition serial number.
- **Partition WWide Node**– The partition WWide node number.
- **Number of Drives** – Number of drives in this partition.
- **Number of Slots** – Number of slots in this partition.
- **Number of Mailslots** – Number of mailslots in this partition.
- **Barcode Label Length Rep. to Host** – Barcode length reported to the host.
- **Barcode Label Alignment Rep. to Host** – Barcode alignment reported to the host.
- **Auto Clean** – Indicates whether automatic cleaning of drives is enabled or disabled.
- **Key Manager Type** – Encryption type.
- **Active Control Path Drive** – LUN drive for this partition.
- **LTO7 Multi-initiator SCSI Conflict Detection** – Indicates whether Multi-initiator Conflict Detection is enabled or disabled.

Click **Refresh** to update the status. Click **Expand All** to expand all partition data sections. Click **Collapse All** to collapse all partition data sections to just option bars.

## Drive Status

In the **Status> Drive Status** page you can see the configuration and status of each drive installed in the library.

**Status > Drive Status**

1	S/N: 11C38DE05B	IBM LTO 7 HH FC	✔	Idle	On
Vendor: <b>IBM</b>		Personality: <b>00 19</b>			
Firmware: <b>HB83</b>		Manufacturer S/N: <b>10WT003567</b>			
Powered: <b>On</b>		WWNN: <b>5000E111C38DE05B</b>			
Temperature: <b>38 °C</b>		Partition: <b>1 (Library LUN)</b>			
Encryption: <b>Disabled</b>		Cartridge: <b>AE0513L7 (1.3)</b>			
IP Address: <b>N/A</b>		Media Removal: <b>Allowed</b>			
Module Loc: <b>1</b>		Data Compression: <b>Enabled</b>			
Cooling Fan Status: <b>Active</b>		Product ID: <b>ULTRIUM-HH7</b>			
SCSI Element Addr: <b>1</b>					
<hr/>					
<b>Port A Status</b> (WWPN: 5000E111C38DE05C)					
Speed:	<b>8 Gb/s</b>	Port Type:	<b>Loop (L)</b>		
Interface:	<b>Login complete</b>	Loop ID / ALPA:	<b>0x6F / 0x26</b>		
<hr/>					
<b>Port B Status</b> (WWPN: 5000E111C38DE05D)					
Speed:	<b>N/A</b>	Port Type:	<b>N/A</b>		
Interface:	<b>No light detected</b>	Port ID:	<b>N/A</b>		
<hr/>					
<input type="button" value="Refresh"/> <input type="button" value="Expand All"/>					

Click **Refresh** to update the status. Click **Expand All** to expand all partition data sections. Click **Collapse All** to collapse all partition data sections to just option bars.

## Network Status

**Status > Network Status**

Host Name: TL-1C38DE  
Domain Name: devnet.myoverland.net

▲ Primary Network Port

▲ General Network Settings

MAC Address:	00:0e:11:1c:38:de	Link Status:	Enabled
Link Speed:	1000 Mbit/s	Duplex:	Enabled
Protocol:	IPv4		

▲ IPv4

DHCP:	Enabled		
Address:	10.20.12.2	Netmask:	255.255.0.0
Gateway:	10.20.8.1		
DNS 1:	10.1.8.154	DNS 2:	10.1.8.155

▲ Secondary Network Port

▲ General Network Settings

MAC Address:	00:0e:11:1c:38:df	Link Status:	Disabled
Link Speed:	Mbit/s	Duplex:	Disabled
Port Enabled:	Disabled		
Protocol:	IPv4		

The **Status > Network Status** page shows:

- **Host Name** – Library hostname.
- **Domain Name**
- **Protocol** – IPV4 or IPV6.
- **MAC Address** – A unique identifier for the library controller network interface.
- **Link Status** – Enabled or disabled.
- **Link Speed** – The speed of the Ethernet connection to the library.
- **Duplex** – Enabled or disabled.
- **IPv4** settings:
  - **DHCP** – When Enabled, the library requests an IP address from a DHCP server each time the library is powered on.
  - **Address** – IP address in use by the library. If DHCP is enabled, this address was obtained from the DHCP server. When DHCP is not enabled, the address was configured.
  - **Netmask** – The network mask of the library controller used when DHCP is not enabled.
  - **Gateway** – The gateway used when DHCP is not enabled.
  - **DNS 1**
  - **DNS 2**
- **IPv6** settings:
  - **Stateless Addressing** – When enabled, the device generates an address for itself based on the routing information obtained from a router advertisement and the MAC address. The device can manage up to five global addresses at the same time, which can be assigned from different routers.

- **Static Addressing** – When enabled, the library uses a statically-configured address.
- **Static Assigned Address** – The IPv6 address when **Static Addressing Enabled** is On.
- **MAC Address**
- **Link Speed**
- **Port Enabled**
- **Link Status**
- **Duplex**
- **Protocol**

## Security Status

In the **Status > Security Status** page you can see the security encryption type status and that of each partition and installed drive in the library.

**Status > Security**

▲ Security Encryption Status

**KMIP:** Disabled, Unlicensed

▲ Partition Encryption Status

▲ Partitions

Partition Number:	Partition Name and S/N:	Encryption Configuration:
1	Partition1, DE56400017_LL01	Controlled by Backup Application

▲ Drive Encryption Status

Drive	Encryption	Partition No.
Drive 1	Disabled	1
Drive 2 Offline	Disabled	N/A

There are three areas on this page:

- [Security Encryption Status](#)
- [Partition Encryption Status](#)
- [Drive Encryption Status](#)

### Security Encryption Status

- **KMIP** – Enabled and licensing statuses.

### Partition Encryption Status

Click each partition option bar to view the following:

- **Partition Number**
- **Partition Name and S/N** (Serial Number)
- **Encryption Configuration**

### Drive Encryption Status

The table has three columns for each drive's encryption status:

- **Drive** – A list of installed drives.
- **Encryption** – The status of encryption on each drive.
- **Partition No.** – The partition with which the drive is associated.

# 7

## Service and Upgrades

Only qualified personnel who are informed about the procedures and risks should service or upgrade the NEOx1 40 Tape Library hardware. Read all troubleshooting documentation and procedures before proceeding with repair or upgrade procedures.



**WARNING:** To reduce the risk of electric shock or damage to equipment, always remove any power cords while working with the library.

**WARNUNG:** Um das Risiko eines elektrischen Schlags oder Schäden am Gerät zu vermeiden, ziehen Sie stets den Netzstecker, bevor Sie an der Einheit arbeiten.

**AVERTISSEMENT:** Pour réduire le risque de choc électrique ou endommagement de l'équipement, retirez toujours les cordons électriques en travaillant avec l'appareil.

---



**CAUTION:** While working with the library, observe standard Electrostatic Discharge (ESD) precautions to prevent damage to micro-circuitry or static-sensitive devices.

---

If needed, contact Technical Support for more information.

Here is a list of possible tools you can need:

- #2 Phillips Screwdriver
- Small Flat-head or Torx Screwdriver
- T10 Torx Screwdriver
- Small Flat-head Screwdriver
- Clip Nut Installation Tool

### Topics in Service and Upgrades:

- [Identify a Failed Component](#)
- [Install or Replace a Tape Drive](#)
- [Replace a Power Supply](#)
- [Replace a Controller Board](#)
- [Install or Replace a Drive Power Board](#)
- [Adding an Expansion Module](#)
- [Replace a Module \(Base or Expansion\)](#)
- [Move a Tape Library](#)
- [Replace the Robotic Assembly and Spooling Mechanism](#)
- [Replace the Base Module Front Bezel/OCP](#)

## Identify a Failed Component

Use the RMI to identify a failed component:

1. From the **Maintenance > UID LED Control** RMI page, activate the UID (Unit Identification) LEDs.  
This illuminates the blue LED on the front and rear of the Base Module to identify the library containing the failed component.
2. Identify the module within the library that contains the **failed component**:
  - a. In the upper left corner of the Home page, locate the **module** that indicates an error.
  - b. Click the **module** for information on the failed component.

## Install or Replace a Tape Drive

---

 **IMPORTANT:** Review “[Electrostatic Discharge](#)” in the [Preface](#) before replacing a library component.

---

### Remove a Tape Drive

Before replacing a tape drive:

- Make sure the tape cartridge has been removed from the tape drive. Use the OCP or the RMI to move the cartridge to a storage slot or mailslot.
- If you are replacing the tape drive in a single drive unit or the master drive in a multi-drive unit, verify that backups are not occurring on the drive you are replacing. If backups are occurring on the master drive, verify that the autoloader or library will not be accessed through this drive while the drive is being replaced.

To remove a tape drive:

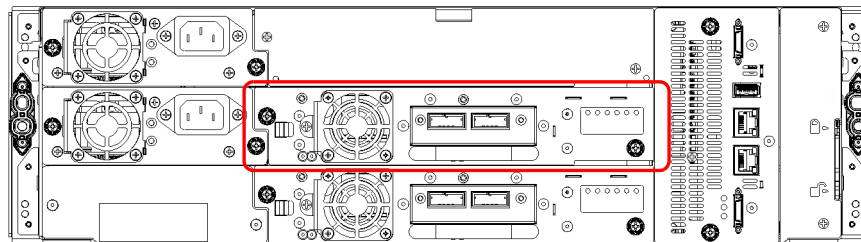

1. Use the OCP or RMI to power off the **tape drive**.
2. Verify that the tape drive assembly LED is off, and then remove the **FC or SAS cable** from the tape drive.
3. Loosen the **blue captive thumbscrews** on the tape drive.

4. Pull straight back using the tape **drive handle** (while supporting the bottom) to remove it from the unit.

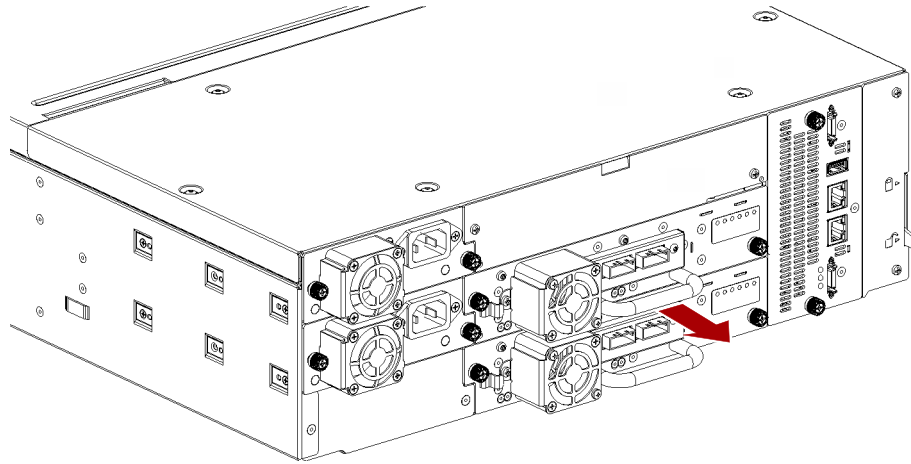

Continue with [Install a Tape Drive on page 128](#).

## Remove a Drive Bay Cover

If installing an additional tape drive in a module, you need to remove one half-height drive bay cover to install a half-height (HH) drive or two HH covers to install a full-height (FH) drive.

1. Identify the **location** for the tape drive.

If this is the first tape drive, install it in the bottom drive bay. Otherwise, install the new drive in the next higher drive location.

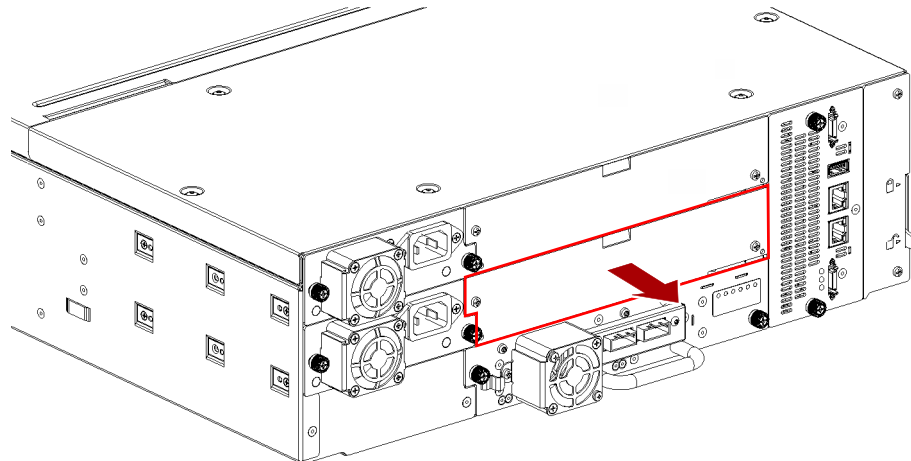

2. Use a #2 Phillips screwdriver to remove the **two screws** securing the plate. Save the plate and screws for possible future use.



## Install a Tape Drive

To install a tape drive:

1. While supporting the drive assembly on the bottom, align and slowly insert the **new tape drive** into the open drive bay.

The tape drive should be flush with the back panel of the device when inserted.

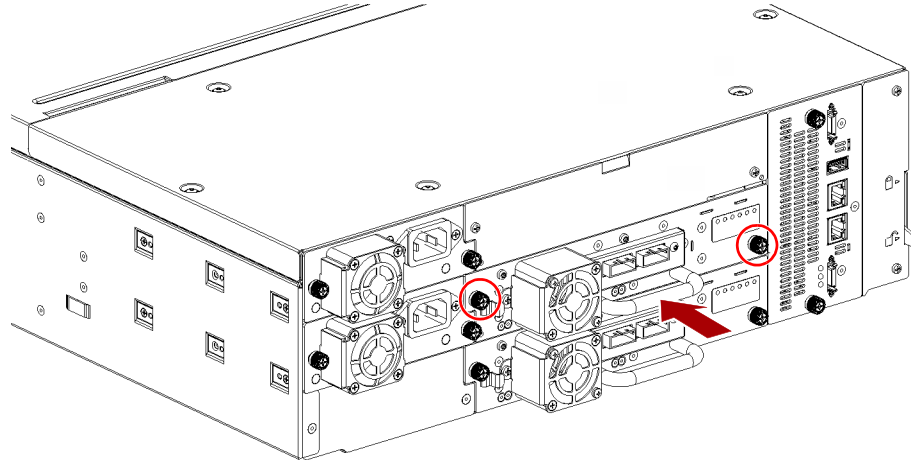

2. Tighten the **blue captive thumbscrews** with your fingers until the tape drive is secure.

## Connect the Drive Cables

### Connect a SAS Cable

1. Attach the **HBA end** of the SAS cable into the connector on the HBA.

If you are using a SAS fanout cable, the end with only one connector should be plugged into the HBA.

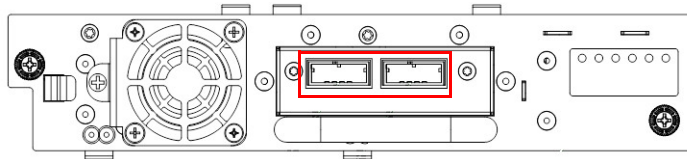

2. Connect the **drive end** of the cable.
  - If you are using a cable with a single connector on each end, attach the other end into the connector on the tape drive.
  - If you are using a SAS fanout cable, attach one mini-SAS connector into the connector on each tape drive. The unused ends of the SAS fanout cable are single channel and not suitable for use with disk arrays. Either use the other ends to connect tape drives, or coil and secure them to the rack to minimize stress on the connectors.

**NOTE:** Each of the tape drives uses one channel and the fanout cable recommended for use with the library maps each of the four channels from the HBA to one channel on the drive end. You can plug any of the four drive connectors into any tape drive.

**Tip:** If you are not using a SAS cable specified for the library, do not force a SAS cable's mini-SAS connector into the tape drive mini-SAS connector because it might be keyed differently.

**NOTE:** SAS signal rates require clean connections between the HBA and tape drive. Do not use adapters or converters between the HBA and the tape drive. For reliable operation, use a maximum SAS cable length of six meters.

### Connect A Fibre Channel Cable

1. If necessary, remove the **FC port caps**.
2. Attach one end of the FC cable to **Port A** on the tape drive.

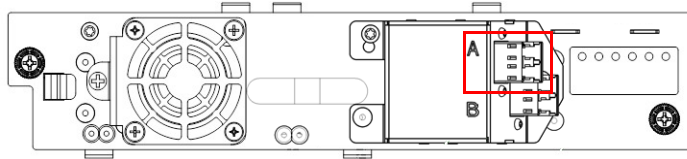

3. Attach the other end of the FC cable to a **switch or HBA**.

When installing a new tape drive, it is recommended that you leave the FC interface settings at the default settings of **Port Speed: Automatic** and **Port Type: Auto Detect**. With these settings, the tape drive uses the appropriate configuration.

### Verify the Installation

1. If necessary, power on the **drive** from the OCP or RMI.
2. Confirm that the **library** recognizes the new tape drive.  
The new drive should appear in the module status overview area on the left side of the OCP screen or RMI page.
3. Verify that the tape drive has the **current firmware**.  
Update the firmware if necessary. You can update firmware from the RMI (**Maintenance > Firmware Upgrades > System Firmware**) or the OCP (**Maintenance > Library Firmware Upgrade**).

## Replace a Power Supply



**IMPORTANT:** Review “[Electrostatic Discharge](#)” in the [Preface](#) before replacing a library component.

### Identify the Failed Component

Use the RMI page (**Maintenance > UID LED Control**) to activate the UID (Unit Identification) LEDs to locate the library in the data center. For detailed instructions, see [Identify a Failed Component on page 126](#).

### Prepare to Remove the Power Supply

Locate the failed power supply on the rear of the library by either the bottom green LED (2) unlit or both LEDs unlit.

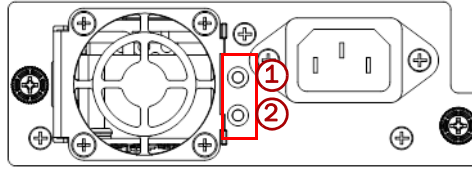

Unplug the AC power cord from the power supply you are replacing.

## Remove the Power Supplies

1. Loosen the two **blue captive thumbscrews** with your fingers on the power supply.
2. Use the **thumbscrews** (one on each side) to slowly pull the power supply out about 4 inches (10cm).
3. While supporting the bottom, remove the **power supply** from the module.

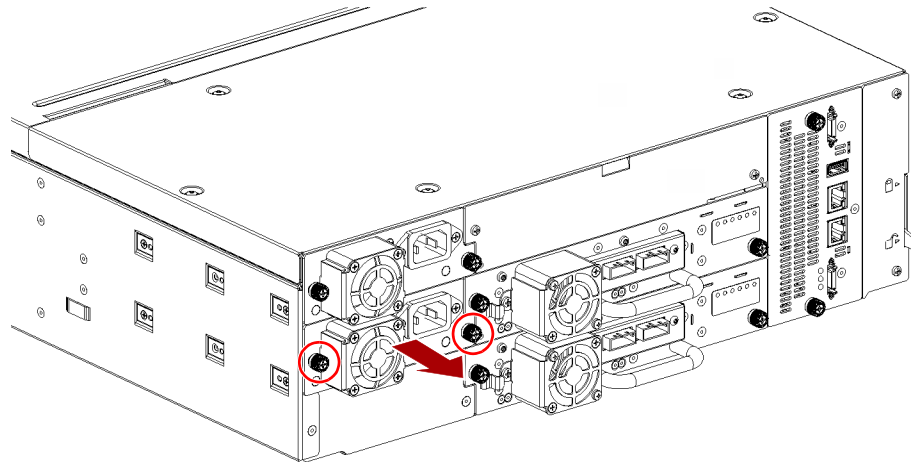

## Install the New Power Supply

1. Position the new power supply onto the **alignment rails**.
2. Slide the **power supply** into the module until it is flush with the back panel of the module.
3. Tighten the **blue captive thumbscrews** with your fingers to secure it to the module.
4. Attach the **AC power cord** to the new power supply.

## Verify the Power Supply Installation and Operation

1. Verify that the new power supply is operating properly by checking that **both power supply LEDs** are lit.
2. Using the RMI, confirm that the **event** that indicated the power supply was faulty should be cleared.
3. If the **UID LEDs** are still illuminated, deactivate them using the RMI.

## Replace a Controller Board



**CAUTION:** You must power off the library to install or replace this part to prevent damage from occurring.



**IMPORTANT:** Review “[Electrostatic Discharge](#)” in the [Preface](#) before replacing a library component.

**NOTE:** Do not replace both the base chassis and the Base Module controllers in the same procedure. The firmware does not allow the library to operate if both components are replaced at the same time. The library WWID and serial number are saved in the controller and within the chassis. When one is replaced, the data from the original component is transferred to the repair component. If replacing both the base chassis and Base Module controller, you must power cycle the library between component replacements.

### Identify the Failed Component

Use the RMI page (**Maintenance > UID LED Control**) to activate the UID (Unit Identification) LEDs to locate the library in the data center. For detailed instructions, see [Identify a Failed Component on page 126](#).

### Save the Configuration

The library configuration settings are on the library chassis and are restored automatically when the controller is replaced. However, it is recommended to save the configuration settings before removing the controller board as a precaution. See [Chapter 6, “Save/Restore Library Configuration,”](#) for instructions on saving configuration settings to a file or USB flash drive.

### Power Off the Library

1. From the front panel, press and hold the **power button** for three (3) seconds.



If the library does not perform a soft shutdown, press and hold the power button for ten (10) seconds.

2. Verify that the **Robotic Assembly** is in its parked position.
3. Verify that all **host processes** are idle.

### Prepare to Remove the Controller

1. Unplug the **AC power cables** from the module containing the failed controller.
2. If present, remove the **expansion interconnect cables** that connect to other modules.
3. If present, remove the **Ethernet cables** and the **USB device**.  
Expansion Module controllers do not have Ethernet or USB ports.

## Remove the Controller

1. Loosen the two **blue captive thumbscrews** on the controller.
2. Using the thumbscrews, slowly remove the **controller** from the module.

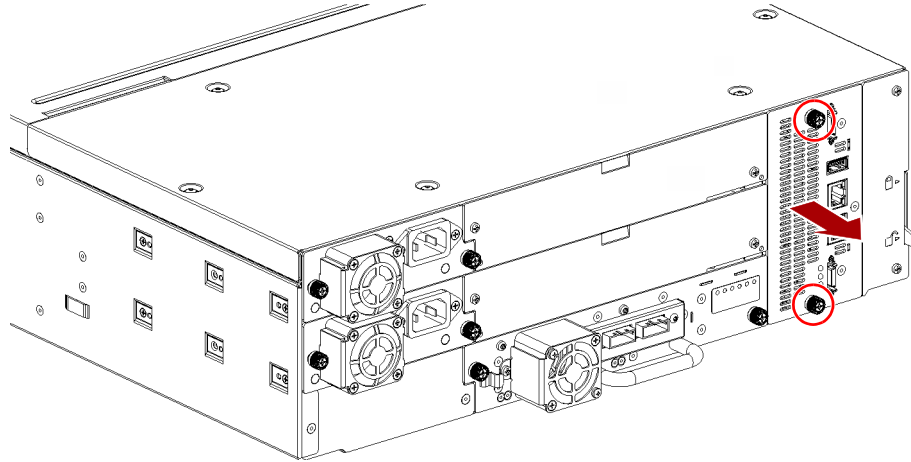

## Install the Controller

1. Position the **new controller** on the alignment rails.
2. Slowly slide the controller into the **module** until it is flush with the back panel of the module.
3. Tighten the **blue captive thumbscrews** with your fingers to secure it to the module.
4. If previously removed, replace the **expansion interconnect cables**.
5. If previously removed, replace the **Ethernet cables** and **USB device**.
6. Plug in the **AC power** cables.

## Verify the Controller Installation

1. Using the OCP or RMI, click **Status > Library Status > Module x** to view the controller status.
2. Check that the **event** indicating the controller was faulty is now cleared.
3. Verify that the library has the most up-to-date **firmware** revision.  
To find the version of firmware installed on the library, check the upper left corner of the OCP or RMI.

Serial #:	CE16400017
Hostname:	TL-1C38DE
IPv4:	10.20.12.2
Firmware:	1.0.2-0000

4. If necessary, update the firmware using the RMI **Maintenance > Firmware Upgrades > System Firmware** page.
5. If replacing the Base Module controller, restore the **previous settings** by restoring them from a file of saved settings, or by entering them using the OCP or RMI.
6. If the **UID LEDs** are still illuminated, deactivate them using the RMI.

7. Resume the **host applications**.

## Power On the Library

Power on the library by pressing the power button just below the OCP display. The green light illuminates.

When the library is powered on, it inventories the tape cartridges in the magazines, checks the firmware version on all modules, configures the tape drives, confirms the presence of the existing modules, and searches for any new modules.

## Install or Replace a Drive Power Board



**IMPORTANT:** Review “[Electrostatic Discharge](#)” in the [Preface](#) before replacing a library component.

### Identify the Failed Component

Use the RMI page (**Maintenance > UID LED Control**) to activate the UID (Unit Identification) LEDs to locate the library in the data center. For detailed instructions, see [Identify a Failed Component on page 126](#).

### Power Off the Library

1. From the front panel, press and hold the **power button** for three (3) seconds.



If the library does not perform a soft shutdown, press and hold the power button for ten (10) seconds.

2. Verify that the **Robotic Assembly** is in its parked position.
3. Verify that all **host processes** are idle.

### Prepare to Remove the Drive Power Board

Unplug the AC power cords from the module containing the failed Drive Power Board.

### Remove the Library/Expansion Controller and Drive Power Boards

The Drive Power Board is located inside the Controller bay.

1. Loosen the **two blue captive thumbscrews** on the library/expansion controller.
2. Using the thumbscrews, slowly remove the **controller** from the module and set it on a secure ESD surface.
3. Push the Drive Power Board **latch** down to release it.

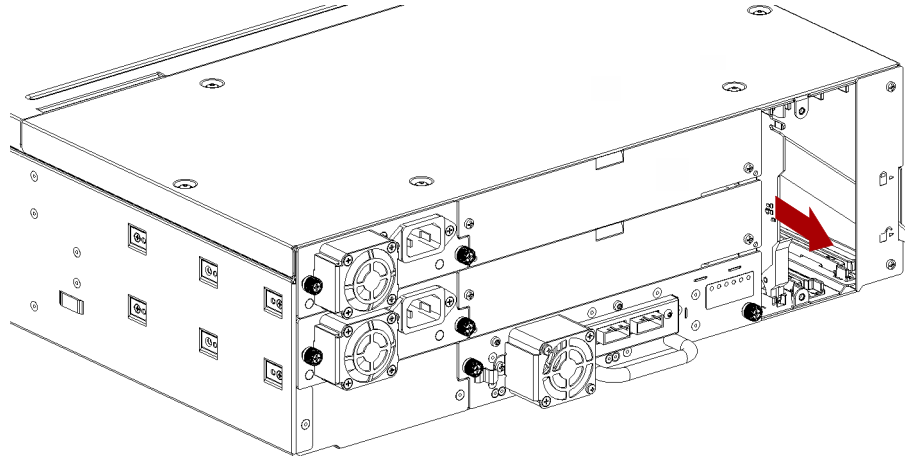

4. Slowly slide the **Drive Power Board** out of the module.

### Install the New Drive Power Board

1. Position the **new Drive Power Board** onto the alignment rails.
2. Slide the Drive Power Board into the **module** until seated firmly.
3. Push the board **latch** up until it snaps firmly into place.  
When the Drive Power Board is installed correctly, the latch will not be loose.
4. Position the **controller** on the alignment rails and slide it in until it is flush with the back panel of the module.
5. Tighten the **thumbscrews** with your fingers to secure it to the module.
6. Plug in the **AC power cords** disconnected previously.

### Power On the Library

Power on the library by pressing the power button just below the OCP display. The green light illuminates.

When the library is powered on, it inventories the tape cartridges in the magazines, checks the firmware version on all modules, configures the tape drives, confirms the presence of the existing modules, and searches for any new modules.

### Verify the Drive Power Board Installation

1. Verify that **all tape drives** that are present are powered on.
2. Check that the **event** indicating the Driver Power Board was faulty is now cleared.
3. From the back of the library, verify that the **green LED** on each drive is illuminated.
4. If the **UID LEDs** are still illuminated, deactivate them using the RMI.
5. Resume the **host applications**.

# Adding an Expansion Module



**IMPORTANT:** Review “[Electrostatic Discharge](#)” in the [Preface](#) before replacing a library component.

## Overview

To install an additional Expansion Module:

1. If necessary, clear space in the rack.
2. Install the rack rails.
3. If necessary, transfer the top or bottom cover to the Expansion Module.
4. Install the Expansion Module in the rack and align the module with the library.
5. Plug in the cables and verify the installation.

You need a small flat-head or Torx screwdriver and a #2 Phillips screwdriver.

## Power Off the Library

1. From the front panel, press and hold the **power button** for three (3) seconds.



If the library does not perform a soft shutdown, press and hold the power button for ten (10) seconds.

2. Verify that the **Robotic Assembly** is in its parked position.
3. Verify that all **host processes** are idle.

## Move a Cover to the New Module

The library has removable top and bottom covers. When adding a module to the top or bottom of the stack, you must move either the top or the bottom cover to the new module. See [Chapter 2, “Preparing Top and Bottom Modules,”](#) for details.

While this procedure refers to moving a cover from the Base Module, the information is the same for moving a cover from an Expansion Module.

## Install the Module in the Rack

See [Chapter 2, “Insert the Modules in the Rack,”](#) for details.

## Align and Connect the Module

Aligning the new module with the library ensures that the robot can move freely between the modules. The library will not operate unless the alignment mechanism is in the locked position. See [Chapter 2, “Aligning and Connecting Modules,”](#) for details.



## Verify the Installation and Configuration

Power on the library and check the following:

- Verify that the library powers on and initializes correctly, and that the status is **Ready**.
- From the OCP or RMI, verify that the new Expansion Module is visible.
- Check the library configuration settings related to the additional storage slots, mailslots, and tape drives. Update if necessary.

The Expansion Module operates using the existing library firmware. It is recommended that you always update the library to the latest firmware version. You can update firmware from the RMI (**Maintenance > Firmware Upgrades > System Firmware**) or the OCP (**Maintenance > Library Firmware Upgrade**).

## Replace a Module (Base or Expansion)



**IMPORTANT:** Review [Chapter 2, “Installation Precautions,”](#) before replacing a module or moving the library. Review the documentation that comes with the replacement module for the latest information about this process.

To replace a module in a NEOxl 40 library:

1. Save the library configuration.
2. Remove tape cartridges and power off the library.
3. Remove the tape drives and disconnect the power cords and cables.
4. Remove the module from the rack and unpack the new module.
5. Swap covers and components from the old to the new module.
6. Install the replacement module into the rack and align it.
7. Reinstall the tape drives and reconnect the power cords and cables.
8. Reinsert the tape cartridges.
9. Power on the library and verify the operation.

You need a T-10 Torx screwdriver to remove the drive bay covers and a small flat-head screwdriver.

## Save the Configuration

The library configuration settings are on the library chassis and is restored automatically when the controller is replaced. However, it is recommended to save the configuration settings before removing the controller board as a precaution. See [Chapter 6, “Save/Restore Library Configuration,”](#) for instructions on saving configuration settings to a file or USB flash drive via the OCP or RMI.

## Prepare Module for Removal

Each NEOxl 40 module weighs more than 44 lbs. (20kg) without drives or tapes and more than 77 lbs. (35kg) with three tape drives and 40 tapes. Before moving or lifting the module, remove the tape magazines and drives to reduce the weight.

## Remove the Tape Cartridges

**IMPORTANT:** As a best practice, perform this procedure while applications are idle. While the magazine is pulled or removed, the library Robotic Assembly cannot move media. Only one magazine can be open at a time.

- Using either the magazine **unlock buttons** or RMI, unlock a tape magazine.

**NOTE:** If these methods fail, or if a magazine needs to be removed when the power to the device is off, you can release the magazine manually. Refer to [Using the Magazine Manual Release](#) on page 169.

- Supporting it underneath, remove the **tape magazine**.

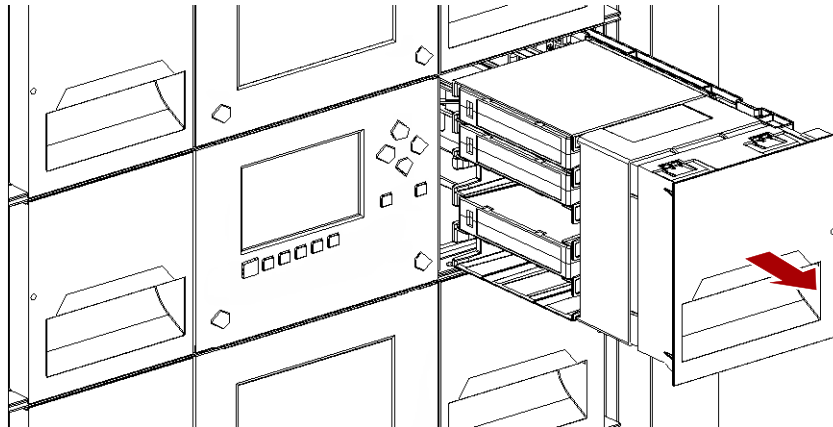

**NOTE:** Do not remove the tape cartridges from the magazine as they need to be in the same slot locations in the new module.

- Repeat these process for the **other** magazine.

## Power Off the Library

- From the front panel, press and hold the **power button** for three (3) seconds.



If the library does not perform a soft shutdown, press and hold the power button for ten (10) seconds.

- Verify that the **Robotic Assembly** is in its parked position.
- Verify that all **host processes** are idle.

## Remove the Cables

Where applicable for the module being replaced:

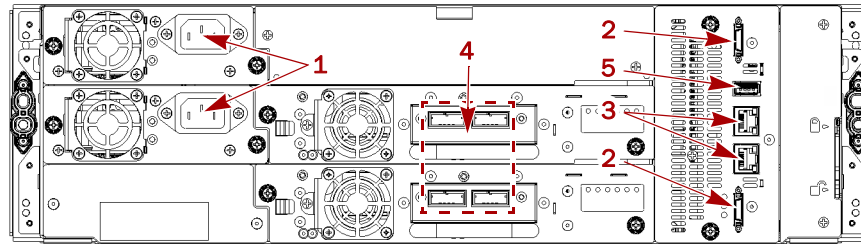

1. Remove all the **power cords** (1).
2. Unplug the **expansion module interconnect cables** (2) from the unit and the modules to which they are connected.

**NOTE:** Completely removing the cables from both ends prevents damaging the expansion interconnect cables during module removal and replacement.

3. When replacing a Base Module, if necessary, remove any **Ethernet cables** (3) from the module.
4. Remove and label **SAS/FC cables** (4) from the drives.
5. When replacing a Base Module, if necessary, remove the optional **USB device** (5).

### Remove the Tape Drives

Where applicable for the module being replaced:

**NOTE:** Because library tracks the drive locations and issues events if the drives aren't in the expected locations, make a note of the drive locations and label the drives so they can be replaced in the same drive bays.

1. Use your fingers to loosen the **blue captive thumbscrews** on the tape drive.
2. While supporting the bottom of the drive, pull straight back on the tape **drive handle** to remove it from the module.

---

**CAUTION:** Support the bottom of the tape drive when removing it to avoid damaging any of the internal connections.

---

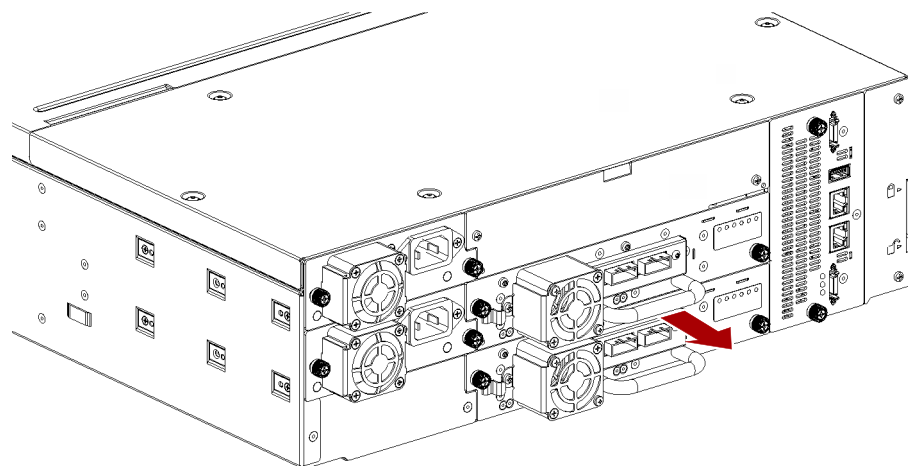

3. Place the drive on a secure **ESD surface**.
4. Repeat this process for any **additional drives**.

## Remove Module from Rack



**WARNING:** To avoid injury, we recommend the use of a mechanical lifting aid (or at least two persons) for rack installation or removal. Use caution during rack installation or removal to avoid accidentally tilting or tipping the rack or injuring yourself.

**WARNUNG:** Um Verletzungen zu vermeiden, empfehlen wir zur Rack-Installation oder -Deinstallation die Nutzung einer mechanischen Hebehilfe (oder mindestens zwei Personen). Seien Sie vorsichtig bei der Rack-Installation oder -Entnahme, um ein versehentliches Kippen des Racks zu vermeiden und das Rack nicht zu beschädigen bzw. sich selbst zu verletzen.

**AVERTISSEMENT:** Afin d'éviter des blessures pendant l'installation, il est recommandé d'utiliser un monte-charge (ou au moins deux personnes) pour élever ou aligner l'module. Faites attention lorsque vous insérez ou retirez l'module d'un support, pour empêcher le déversement accidentel de la crémaillère causant des dommages et des blessures.

1. From the front, use a #2 Phillips screwdriver to loosen the **recessed screws** two full turns on both the module and any adjacent modules.

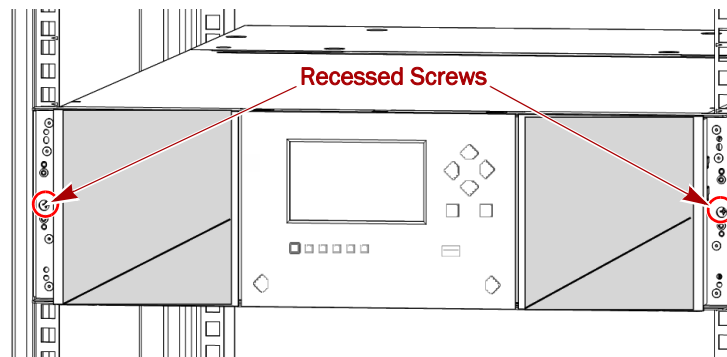

2. From the back of the library, unlock the **alignment mechanisms** connecting the module with any adjacent modules.
3. Carefully slide the **module** out onto a mechanical lifter.

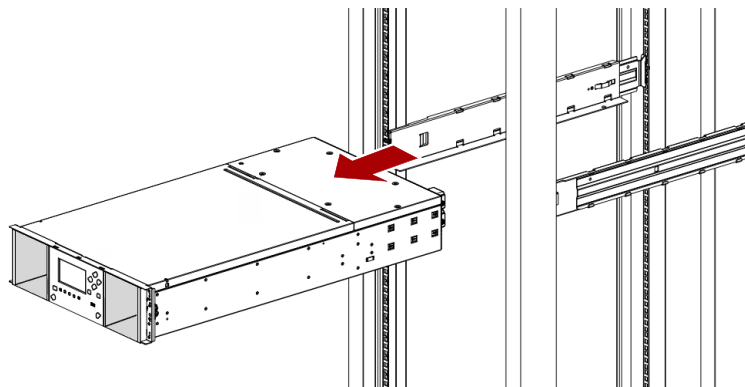

4. Place the module on a secure **ESD surface**.
5. Unpack the **new module** and place in on the surface next to the old module.

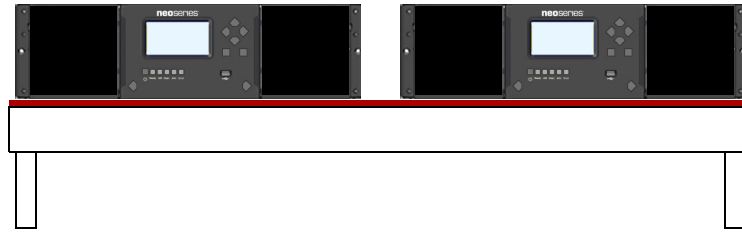

## Move Covers and Components

### Move Covers

**IMPORTANT:** When replacing a module that has a top and/or bottom cover, you must move the covers from the old module to the new one.

To move a **top** cover:

1. At the old module, insert a small flat-head or Torx **screwdriver** into the release holes and slide them about 1/4 inch (6mm) sideways to unlock the spring-loaded locks.

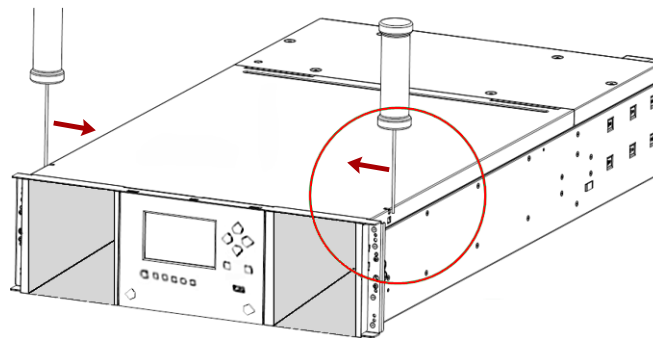

2. Lift the top cover **front edge** by about 4 inches (10cm) and pull the cover gently forward to disengage from the pivot point at the module center.

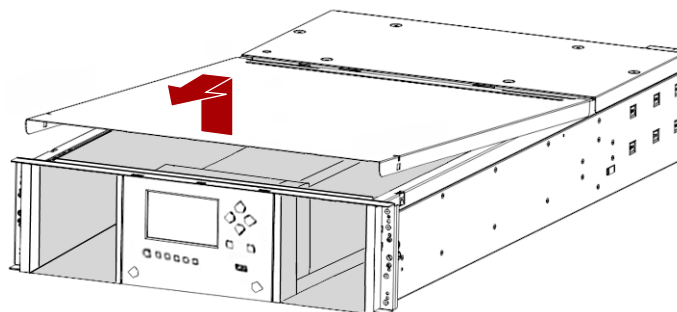

3. At the new module, with the cover at the same angle, reengage the **rear of the cover** at the pivot point.
4. Lower the front of the top cover until the **latches** engage on both sides.

To move a **bottom** cover:

1. Place both modules **upside-down**.
2. At the old module, insert a small flat-head or Torx **screwdriver** into the release hole and slide it about 1/4 inch (6mm) sideways to unlock the spring-loaded lock.

3. Raise the **cover front end** by about 4 inches (10cm) and gently pull it forward to disengage from the pivot point at module center and remove.

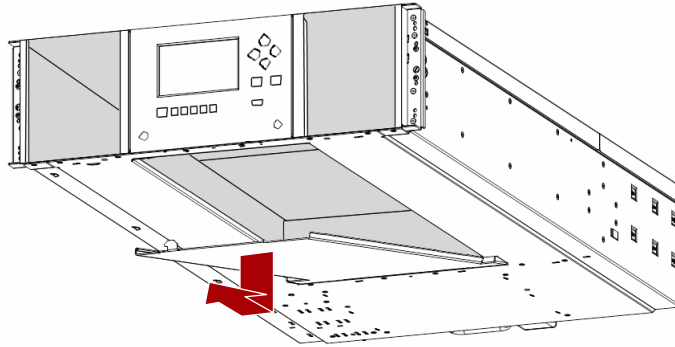

4. At the new module, with the cover at the same angle, reengage the **rear of the cover** at the pivot point.
5. Lower the front of the cover until the **latch** engages.

### Move the Power Supplies

**NOTE:** If any power supplies are installed, they need to be moved to the new module.

1. At the **new** module, remove the appropriate power supply **covers**.
2. At the **old** module, loosen the **two blue captive thumbscrews** with your fingers on the power supply.
3. Use the thumbscrews to pull the **power supply** out about 4 inches (10cm).
4. While supporting the bottom, remove the **power supply**.
5. At the **new** module, position the power supply onto the **alignment rails**.
6. Slide the power supply into the **module** until it is flush with the back panel of the module.
7. Tighten the **thumbscrews** with your fingers to secure it.
8. If necessary, repeat these steps for a **redundant power supply**.
9. Install the removed power supply covers on the **old** module.

### Move Controller

1. At the **old** module, loosen the **two blue captive thumbscrews** on the controller and slowly remove it from the module, setting it aside.
2. If a **Drive Power Board** is installed, also move it:

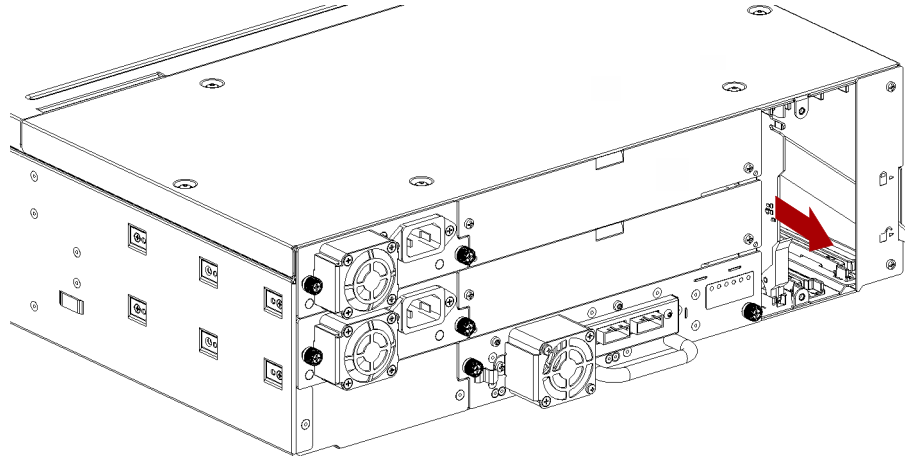

- a. Push down the Drive Power Board **latch** to release it.
  - b. Slowly slide the **Drive Power Board** out of the module.
  - c. At the new module, position the Drive Power Board onto the **alignment rails**.
  - d. Slide the **Drive Power Board** in until seated firmly.
  - e. Push the board **latch** up until it snaps into place.
3. At the **new** module, position the **controller** on the alignment rails and slide it in until it is flush with the back panel of the module.
  4. Tighten the **thumbscrews** with your fingers to secure it to the module.

### Move Drive Bay Covers

If any drive bays on the old Expansion Module have covers installed, they need to be moved to the new Expansion Module.

### Insert the Module in Rack



**WARNING:** To avoid injury, we recommend the use of a mechanical lifting aid (or at least two persons) for rack installation or removal.

**WARNUNG:** Um Verletzungen zu vermeiden, empfehlen wir zur Rack-Installation oder -Deinstallation die Nutzung einer mechanischen Hebehilfe (oder mindestens zwei Personen).

**AVERTISSEMENT:** Afin d'éviter des blessures pendant l'installation, il est recommandé d'utiliser un monte-charge (ou au moins deux personnes) pour élever ou aligner l'module.

1. Using the mechanical lifter, position the **module** in front, aligned with the rack rails.

- Slide the module onto the **rail flanges** and into the rack.

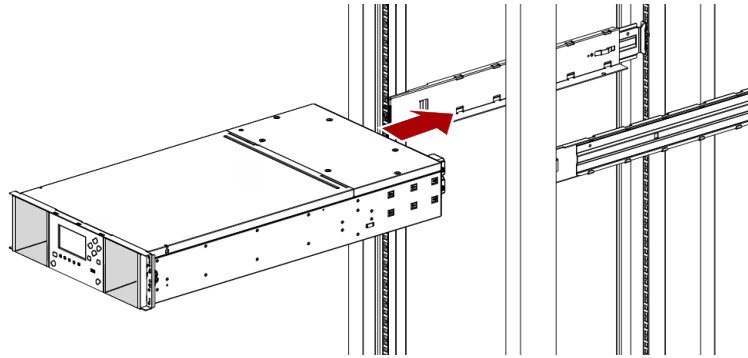

- Tighten the **recessed screws** only one turn to hold the module.

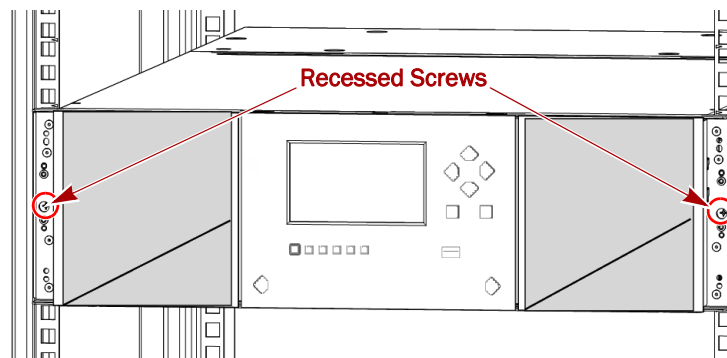

- At the back of the library, using the **alignment lock lever**, align and lock the new module to any adjacent modules.

**NOTE:** The library will not operate unless the alignment mechanism is in the locked position (except the bottom module).

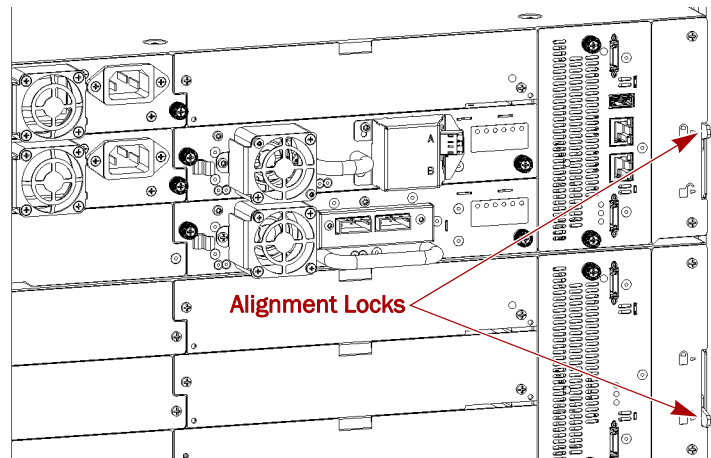

If you encounter resistance, adjust the upper module so that the alignment mechanism pin moves into the mating hole in the lower module.

- Verify that, for the lowest module in the library, its alignment mechanism is in the **unlocked position**.
- From the front of the library, tighten the **Phillips screws** on both the new module and any adjacent modules to secure them all to the rack.



## Complete the Installation

### Reinstall Tape Drives

If any tape drives were in the old module, install them in the same bays in the new module:

1. Holding a **tape drive** by the handle and supporting it from the bottom, position it on the alignment rails of the appropriate bay.
2. Slowly slide the tape drive into the **drive bay** until it is flush with the back of the library.

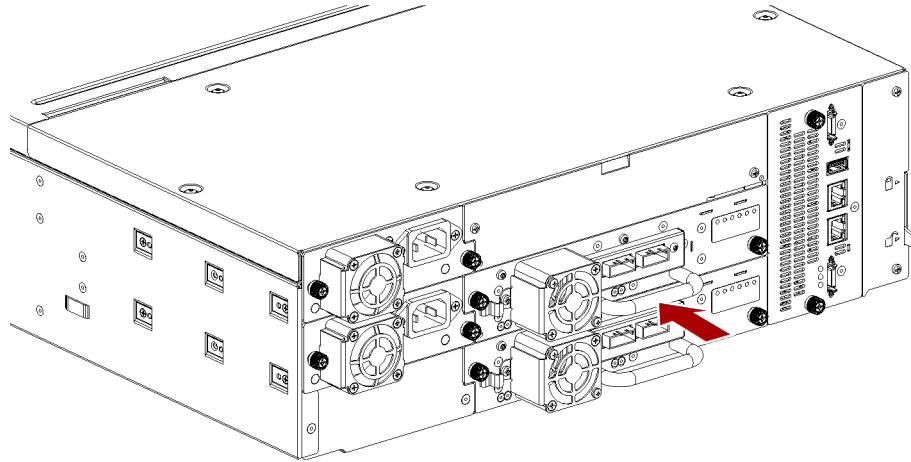

3. Finger-tighten the **blue captive thumbscrews** to secure.
4. Repeat [Steps 1–3](#) for any **additional tape drives**.

### Reattach Cables and Cords

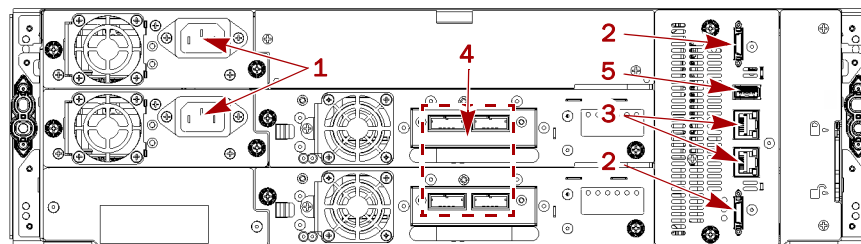

1. Reconnect the **expansion interconnect cables** (2) from the Expansion Module to any adjacent Expansion Modules.
2. If previously removed from the old Base Module, reconnect any **Ethernet management cables** (3).
3. Reconnect any **SAS/FC cables** (4) to the same tape drives.
4. If previously removed from the old Base Module, reinsert the **USB device** (5).
5. Reconnect the **AC power cords** (1) to the power supplies.

### Reinstall Tape Magazines

Reinstall the previously removed tape magazines into the new module.

1. Using the magazine **access handle** and supporting it underneath, position the magazine on the alignment rails.

2. Slide the **magazine** into the module.
3. Repeat [Steps 1–2](#) for the **other magazine**.

## Verify the Library Configuration

Power on the library and check the following:

- Verify that the library powers on and initializes correctly, and that the status is **Ready**.
- From the OCP or RMI, verify that the new module is visible.
- Check the library configuration settings related to the additional storage slots, mailslots, and tape drives. Update if necessary.

The module operates using the existing library firmware. It is recommended that you always update the library to the latest firmware version. You can update firmware from the RMI (**Maintenance > Firmware Upgrades > System Firmware**) or the OCP (**Maintenance > Library Firmware Upgrade**).

## Move a Tape Library



---

**IMPORTANT:** Review [Chapter 2, “Installation Precautions,”](#) before moving the library. When moving a library either within a rack or to a different rack, care must be taken to avoid personal injury and damage to the module.

---

To move a tape library:

1. Save the library configuration.
2. Remove any tape cartridges from the tape drives, remove the tape magazines, and power off the library.
3. Disconnect the power cords and cables, and unlock the alignment mechanisms.



---

**CAUTION:** Failure to disconnect all cables can result to damage to the cable and/or the mating electronic assembly in the library.

---

4. Carefully release and remove the modules from the rack.
5. Remove the rack rails from the rack and, after verifying that the destination rack is level side to side and front to back, install the rails in the destination rack.
6. Carefully install the modules in the rack and lock the alignment mechanisms.
7. Reconnect the cables to the appropriate ports.
8. Connect the power cords, power on the library, and verify the operation.
9. Reinstall the tape magazines.

See [Chapter 2, “Installation”](#) and [Replace a Module \(Base or Expansion\) on page 136](#) for details.

# Replace the Robotic Assembly and Spooling Mechanism

Use this process to replace the Robotic Assembly and Spooling Mechanism in a Base Module.



**IMPORTANT:** Review “[Electrostatic Discharge](#)” in the [Preface](#) before replacing a library component.

## Prepare Module for Removal

Each NEOxl 40 module weighs more than 44 lbs. (20kg) without drives or tapes and more than 77 lbs. (35kg) with three tape drives and 40 tapes. Before moving or lifting the module, remove the tape magazines and drives to reduce the weight.

## Remove the Tape Cartridges



**IMPORTANT:** As a best practice, perform this procedure while applications are idle. While the magazine is pulled or removed, the library Robotic Assembly cannot move media. Only one magazine can be open at a time.

1. Using either the magazine **unlock buttons** or RMI to unlock a tape magazine.

**NOTE:** If these methods fail, or if a magazine needs to be removed when the power to the device is off, you can release the magazine manually. Refer to [Using the Magazine Manual Release](#) on page 169.

2. Supporting it underneath, remove the **tape magazine**.

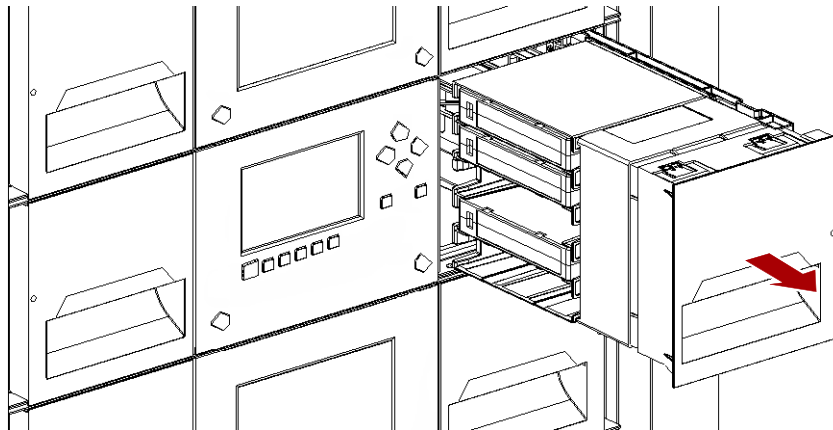

**NOTE:** Do not remove the tape cartridges from the magazine as they need to be in the same slot locations in the new module.

3. Repeat these process for the **other** magazine.

## Power Off the Library

1. From the front panel, press and hold the **power button** for three (3) seconds.



If the library does not perform a soft shutdown, press and hold the power button for ten (10) seconds.

2. Verify that the **Robotic Assembly** is in its parked position.
3. Verify that all **host processes** are idle.

## Remove the Cables

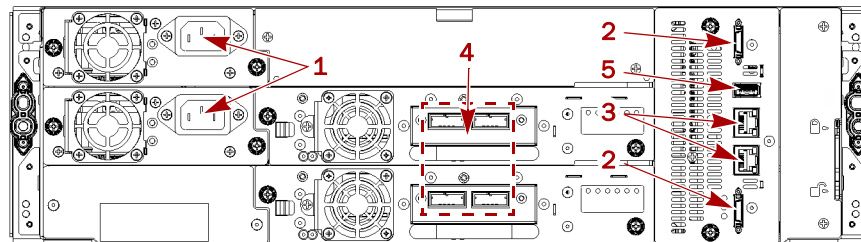

1. Remove all the **power cords** (1).
2. Unplug the **expansion module interconnect cables** (2) from the Base Module and any adjacent modules.

**NOTE:** Completely removing the cables from both ends prevents damaging the expansion interconnect cables during module removal and replacement.

3. Remove any **Ethernet cables** (3) from the module.
4. Remove and label the **SAS/FC cables** (4) from the drives.
5. If present, remove the optional **USB device** (5).

## Remove the Tape Drives

Remove the tape drives to lessen the module's weight.

**NOTE:** Because library tracks the drive locations and issues events if the drives aren't in the expected locations, label the drives so they can be replaced in the same drive bays.

1. Use your fingers to loosen the **blue captive thumbscrews** on the tape drive.
2. While supporting the bottom of the drive, pull straight back on the tape **drive handle** to remove it from the module.



**CAUTION:** Support the bottom of the tape drive when removing it to avoid damaging any internal connections.

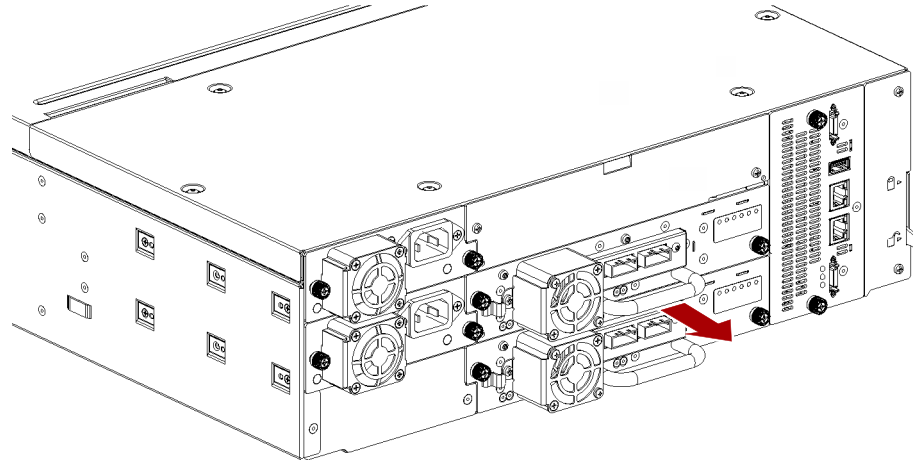

3. Place the drive on a secure **ESD surface**.
4. Repeat this process for any **additional drives**.

## Remove Module from Rack



**WARNING:** To avoid injury, we recommend the use of a mechanical lifting aid (or at least two persons) for rack installation or removal. Use caution during rack installation or removal to avoid accidentally tilting or tipping the rack or injuring yourself.

**WARNUNG:** Um Verletzungen zu vermeiden, empfehlen wir zur Rack-Installation oder -Deinstallation die Nutzung einer mechanischen Hebehilfe (oder mindestens zwei Personen). Seien Sie vorsichtig bei der Rack-Installation oder -Entnahme, um ein versehentliches Kippen des Racks zu vermeiden und das Rack nicht zu beschädigen bzw. sich selbst zu verletzen.

**AVERTISSEMENT:** Afin d'éviter des blessures pendant l'installation, il est recommandé d'utiliser un monte-charge (ou au moins deux personnes) pour élever ou aligner l'module. Faites attention lorsque vous insérez ou retirez l'module d'un support, pour empêcher le déversement accidentel de la crémaillère causant des dommages et des blessures.

1. From the front, use a #2 Phillips screwdriver to loosen the **recessed screws** two full turns on **both** the Base Module and any adjacent modules.

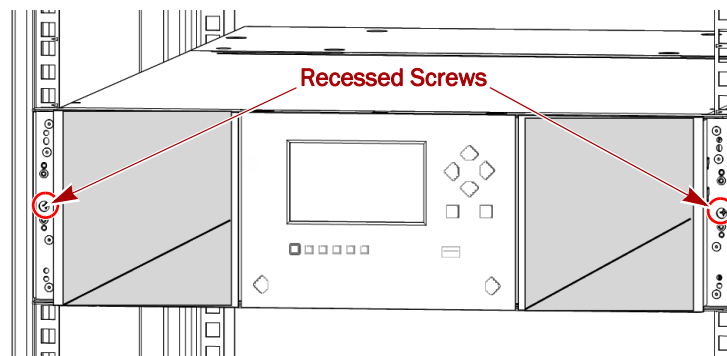

2. From the back of the library, unlock the **alignment mechanisms** connecting the Base Module with any adjacent modules.
3. Carefully slide the **Base Module** out onto a mechanical lifter.

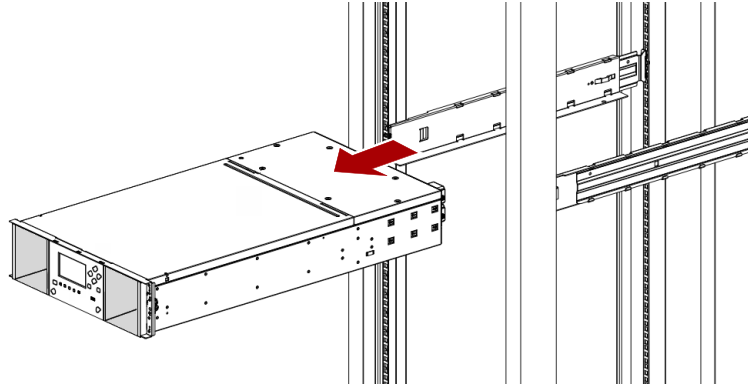

4. Place the module on a secure **ESD surface**.



5. Unpack the new **Robotic Assembly and Spooling Mechanism**, placing them next to the module.

### Remove Top Cover

If the Base Module has a top cover, it must be removed:

1. Insert a small flat-head or Torx **screwdriver** into the release holes and slide them about 1/4 inch (6mm) sideways to unlock the spring-loaded locks.

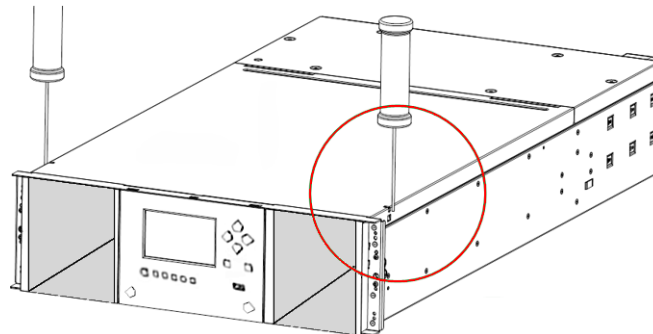

To prevent a side from relocking, it may be necessary to hold its edge up while unlocking the other side.

- Lift the top cover **front edge** by about 4 inches (10cm) and pull the cover gently forward to disengage from the pivot point at the module center.

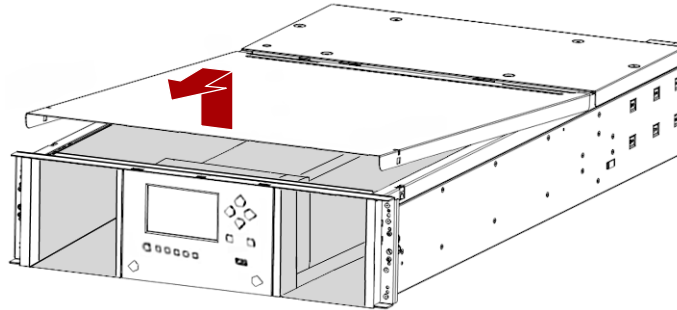

- Place the **cover** on a secure surface for reinstallation after the replacement is done.

## Remove Old Robotic Assembly

Remove the old Robotic Assembly and the Spooling Mechanism for replacement.

### Unlock the Robotic Assembly

**NOTE:** If necessary, slide the robotics' cartridge carrier manually toward the center of the Robotic Assembly to access the blue locking lever.

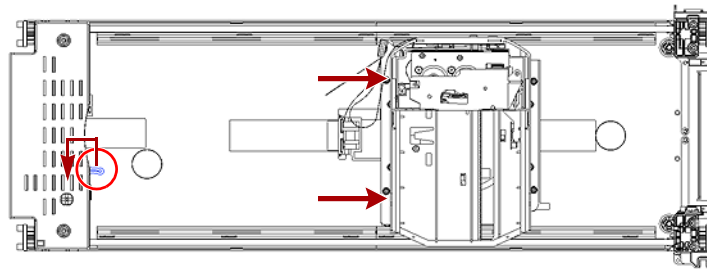

Standing at the front of the module, unlock the robot by moving the **blue lever** to the left, then toward you, then to the right.

If a tape cartridge is still in the Robotic Assembly cartridge carrier, remove the cartridge by lifting it straight up. You may need to move the cartridge slightly from side to side.

### Extract the Robotic Assembly from the Module

Gently pull the Robotic Assembly out of the module.

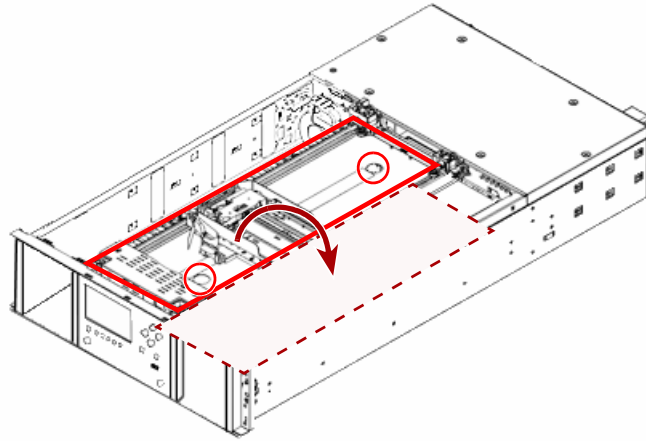

1. Place your fingers into the **large holes** on the Robotic Assembly and pull up slowly (about 1/2 inch [13mm] per second) until clear.
2. Lift the **Robotic Assembly** gently from inside the module and place it on top of the module on the right side (opposite the Spooling Mechanism) and slightly to the front.

**NOTE:** Be careful not to damage the spooling cable.

### Remove the Spooling Mechanism

1. Detach the **spooling cable connector** from the Robotic Assembly:
  - a. Use a small flat-head or Torx screwdriver to press the **small latch** down and out to unlock the **spooling cable connector** on the rear left.

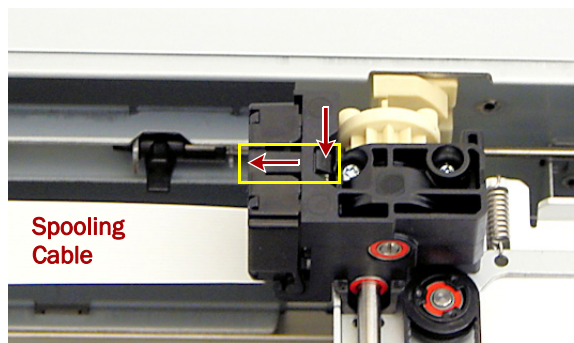

- b. Pivot the **connector** out from the Robotic Assembly, loop the cable over the top of the Spooling Mechanism, and slip the end of the connector into the docking slot at the top.

The spooling cable should lay flat across the top.

**NOTE:** Note the hooks on the Robotic Assembly where the end of the spooling cable pivots. This is important to know when you attach the new spooling cable to the new Robotic Assembly.

2. Move the Robotic Assembly to a secure **ESD surface**.



3. Remove the **Spooling Mechanism** by pressing the latch at the top rear of the Spooling Mechanism and pushing the entire Spooling Mechanism gently to the right until the rear connector releases.

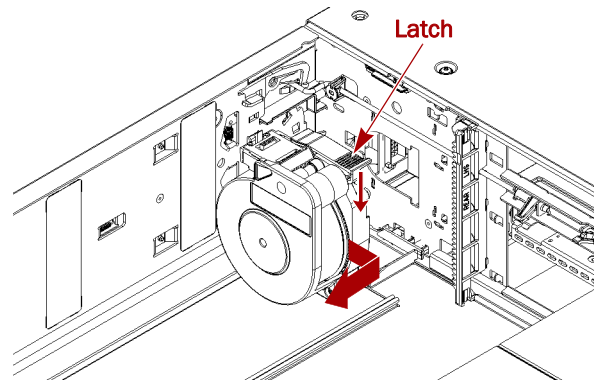

It may help to push the left side with your other hand.

4. Pull the **Spooling Mechanism** to the front, releasing it from the rear metal wall, and set it aside.

## Install the New Robotic Assembly

Install the new Spooling Mechanism and Robotic Assembly in the Base Module.

### Install the New Spooling Mechanism

1. Hold the new **Spooling Mechanism** in front of the rear metal wall attachment point with the docked spooling connector to the top left.

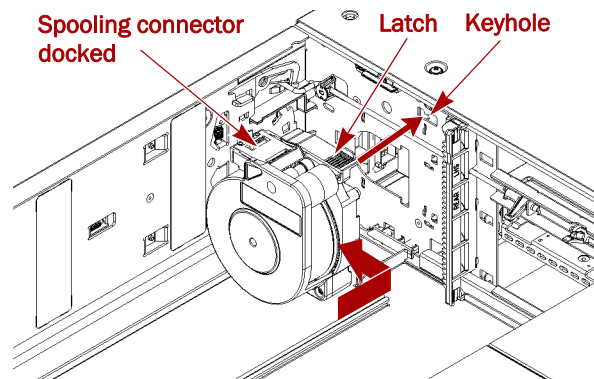

2. Align the **latch** at the top rear of the Spooling Mechanism with the **keyhole** in the rear metal wall.
3. Push the **Spooling Mechanism** in and then to left until the rear plug is connected and the mechanism snaps into place.

It may help to push the right side with your other hand.

### Install the Robotic Assembly

1. Position the **new Robotic Assembly** resting on the right side of the module.
2. Verify that the Robotic Assembly is **unlocked**.  
If not, unlock it by moving the blue lever to the left, then toward the front, and then to the right.

3. Attach the Spooling Mechanism **connector**:

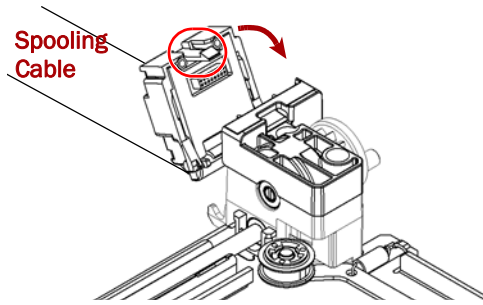

- a. Unlock the **connector** from the Spooling Mechanism top and hold it with the latch end up.
  - b. Place the **cable end** into the Robotic Assembly hooks.
  - c. Pivot the **top** into position so that latch connects.
4. Rotate **one of the corner gears** on the Robotic Assembly so that the two pins are **aligned horizontally**.  
All the gears are synchronized and will also be aligned.
5. Gently place the Robotic Assembly gears onto the top of the **grooves** of the four vertical gear rails.

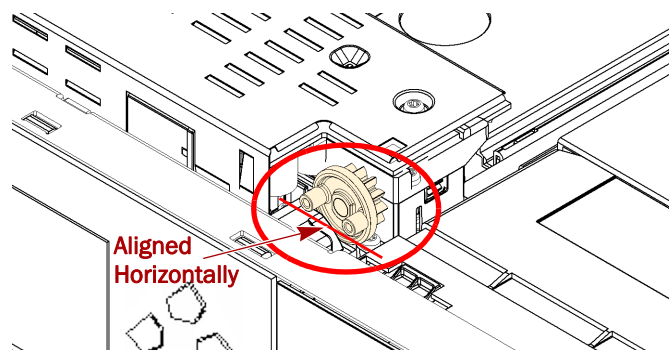
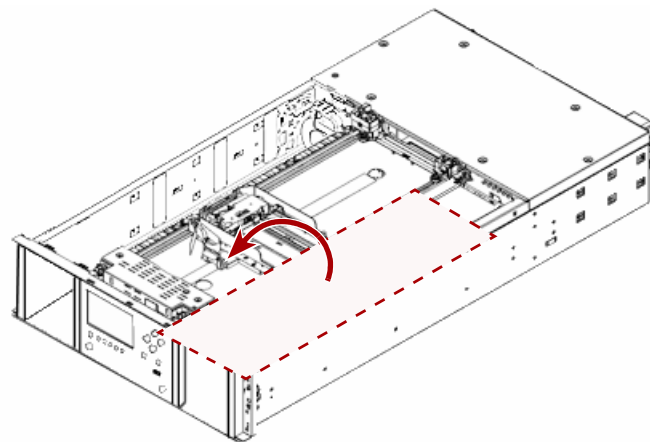

6. Gently push the Robotic Assembly down until the **base** of the Robotic Assembly is on the bottom of the module.



**CAUTION:** Lower the Robotic Assembly no faster than 1/2 inch (13mm) per second. If the Robotic Assembly is not aligned properly or you push too hard or too quickly, damage to the Robotic Assembly and the Base Module may occur.

**NOTE:** The Robotic Assembly should drop smoothly by itself. If it does not, check the alignment of the gears.

7. Lock the Robotic Assembly by moving the **blue lever** to the left, then toward the rear, and then to the right.

## Reinstall the Cover

1. With the cover at the same angle as when it was removed, reengage the **rear of the cover** at the pivot point.

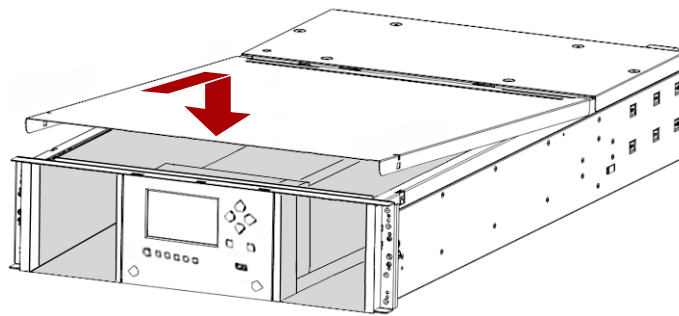

2. Lower the front of the cover until the **latches** engage on both sides.

## Reinsert the Module in Rack

1. Using the mechanical lifter, position the **Base Module** in front of the rack from where it was removed and aligned it with the rack rails.
2. Slide the module onto the **rack rail flanges** and into the rack.

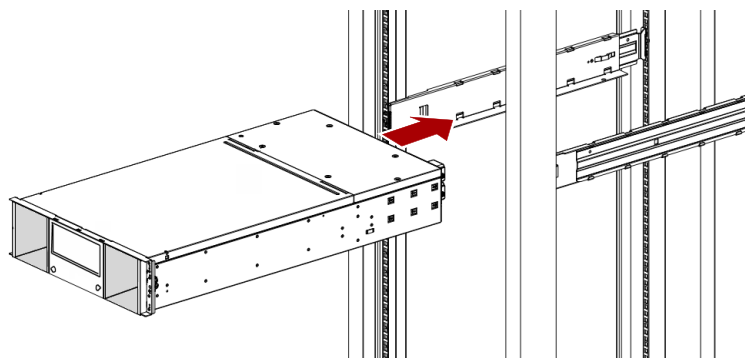

3. Tighten the **recessed screws** only one turn to hold the module.

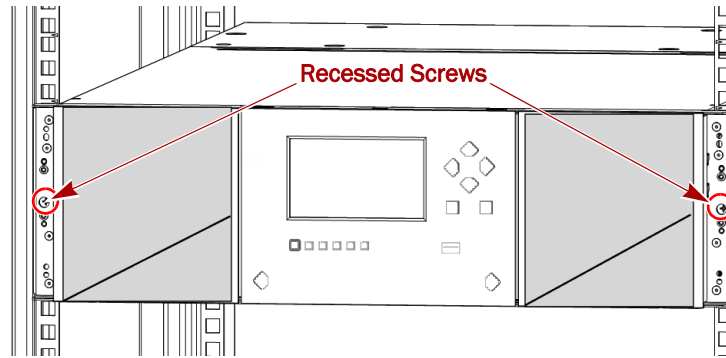

## Aligning and Connecting the Module

Aligning the Base Module with the other library Expansion Modules ensures that the Robotic Assembly can move freely between the modules.

**NOTE:** The library will not operate unless all the alignment mechanisms (except the one on the bottom module) are in the locked position.

1. At the back of the library, using the **alignment lock lever**, align and lock the Base Module to any Expansion Modules to which it connects.

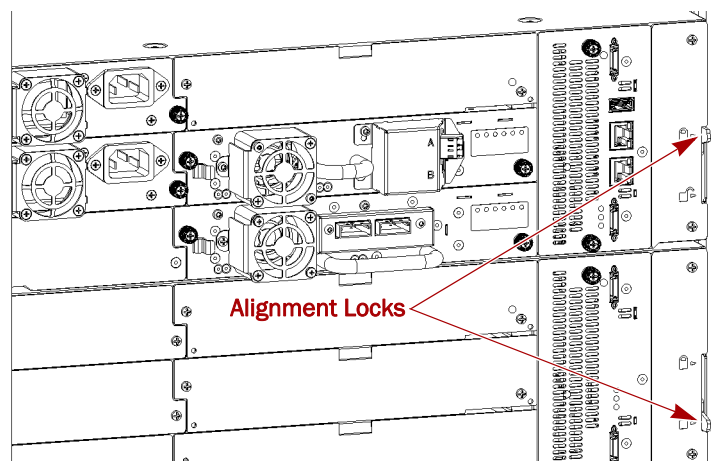

If you encounter resistance, adjust the upper module so that the alignment mechanism pin moves into the mating hole in the lower module.

2. If necessary, verify that the **lowest** module in the library has its alignment mechanism in the **unlocked** position.
3. At the front of the library, tighten the **recessed screws** on both the Base Module and any adjacent Expansion Modules to secure them all to the rack.

## Complete the Reinstallation

### Reinstall Tape Drives

Start with the lowest tape drive bay and install upwards. Ensure that the same drive is going into its appropriate bay.

1. Holding a **tape drive** by the handle and supporting it from the bottom, position it on the alignment rails.

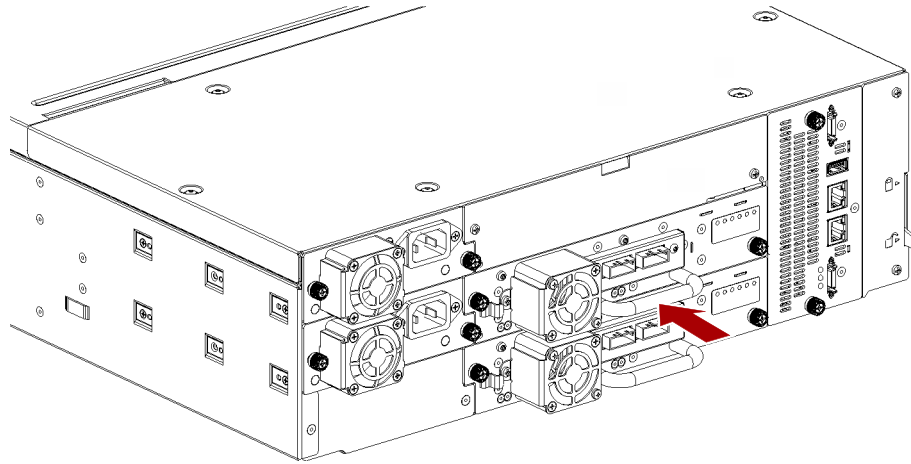

2. Slowly slide the tape drive into the **drive bay** until it is flush with the back of the library.
3. Finger-tighten the **blue captive thumbscrews** to secure.
4. Moving upwards, repeat [Steps 1–3](#) for any **additional tape drives**.

### Reattach Cables and Cords

1. Reconnect the **expansion interconnect cables** (2) from the Base Module to any adjacent Expansion Modules.

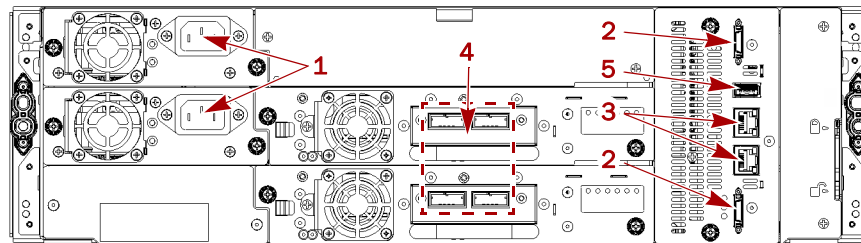

2. Reconnect the **Ethernet management cables** (3).
3. Reconnect the **SAS/FC cables** (4) to the tape drives.
4. If you removed one earlier, reinsert the **USB device** (5).
5. Reconnect the **AC power cords** (1) to the power supplies.

### Reinstall Tape Magazines

Reinstall the previously removed tape magazines (and tapes) into the Base Module.

1. Using the magazine **access handle** and supporting it underneath, position the magazine on the alignment rails of the appropriate bay.

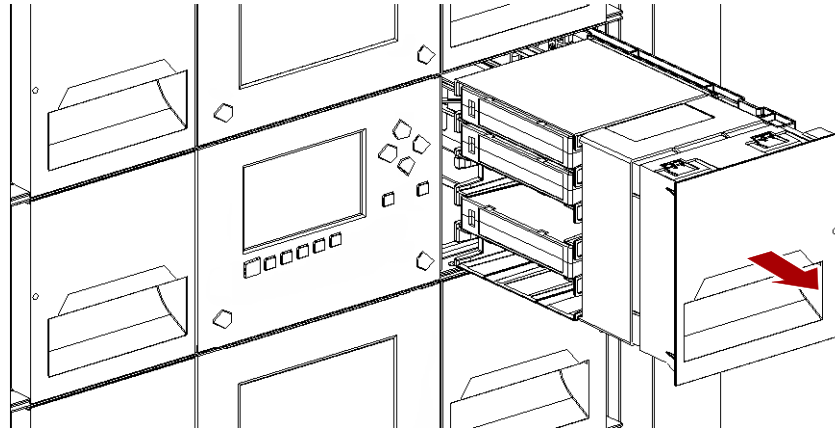

2. Slide the **magazine** into the module.
3. Repeat [Steps 1–2](#) for the **other magazine**.

## Verify the Library Configuration

Power ON the library and check the following:

- Verify that the library powers ON and initializes correctly, and that the status is **Ready**.
- Check the library configuration settings related to the additional storage slots, mailslots, and tape drives. Update the settings if necessary.
- If the UID LEDs are still illuminated, deactivate them using the RMI.

It is recommended that you always update the library to the latest firmware version. You can update firmware from the RMI (**Maintenance > Firmware Upgrades > System Firmware**) or the OCP (**Maintenance > Library Firmware Upgrade**).

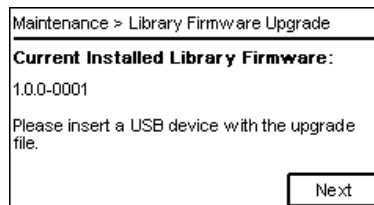

## Replace the Base Module Front Bezel/OCP

- 
-  **IMPORTANT:** Review [“Electrostatic Discharge”](#) in the [Preface](#) before replacing a library component.
-

## Power Off the Library

If the library is still powered on:

1. From the front panel, press and hold the **power button** for three (3) seconds.



If the library does not perform a soft shutdown, press and hold the power button for ten (10) seconds.

2. Verify that the **Robotic Assembly** is in its parked position.
3. Verify that all **host processes** are idle.

## Remove the Tape Magazines

1. To manually release the magazine, insert a small flat-head screwdriver or Torx driver into the appropriate magazine release hole and gently push the tab in.



**IMPORTANT:** Do not exert force once you encounter resistance. Doing so can damage the device.

2. Supporting it underneath, remove the **tape magazine**.

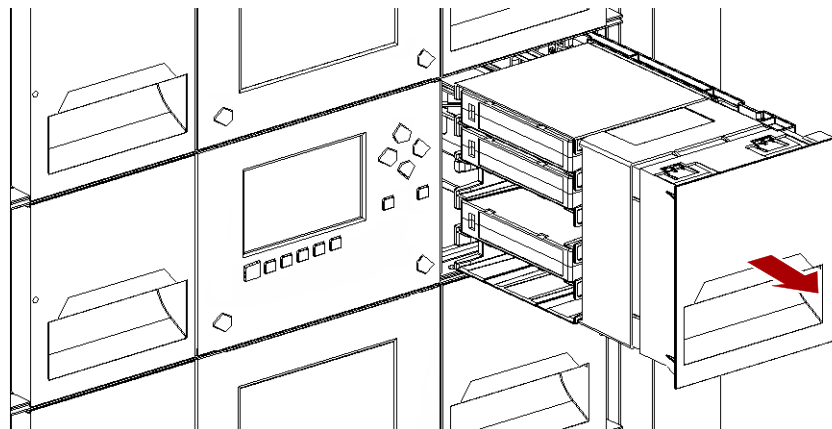

**NOTE:** Do not remove the tape cartridges from the magazine as they need to be in the same slot locations in the new module.

3. Repeat these process for the **other** magazine.

## Remove the Bezel

1. Insert a small flat-head or Torx screwdriver into one the two silver bezel **release holes** at bottom of the center of the bezel.

2. Push the screwdriver until the **bezel** is released.  
Slightly move that side of the bezel out to prevent it from relatching.
3. Insert the screwdriver into the **other hole** and push it in.
4. Swing the bottom of the **bezel** up to release it.

**NOTE:** Pull gently to avoid damaging the OCP cable. Note where the OCP cable is located, routed, and attached.

5. Disconnect the **OCP cable**.

### Install the Bezel

1. Attach the **OCP cable** of the new bezel.
2. Place the top tabs of the bezel into the slots in the **top slots** of the module.
3. Rotate the bezel **bottom** inward until it snaps in place.

### Reinstall Tape Magazines

Reinstall the previously removed tape magazines into the Base Module.

1. Using the magazine **access handle** and supporting it underneath, position the magazine on the alignment rails.
2. Slide the **magazine** into the module.
3. Repeat [Steps 1–2](#) for the **other magazine**.

### Power On the Library

Power on the library by pressing the power button just below the OCP display. The green light illuminates.

When the library is powered on, it inventories the tape cartridges in the magazines, checks the firmware version on all modules, configures the tape drives, confirms the presence of the existing modules, and searches for any new modules.



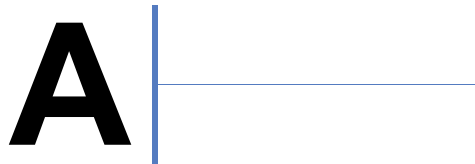

# Troubleshooting

This appendix provides troubleshooting steps for your NEOxl 40 Tape Library.

## Topics in Troubleshooting:

- [Fibre Channel Connection Problems](#)
- [Detection Problems After Installing a SAS Drive](#)
- [Operational Problems](#)
- [Performance Problems](#)
- [Finding Event Information](#)
- [Unlocking a Magazine](#)
- [Unloading a Stuck Tape](#)
- [Returning the Robotic Assembly to the Base Module](#)
- [Running Library Tests](#)

## Fibre Channel Connection Problems

Use the **Status > Drive Status** page to check the link connection for your tape drive.

- If the page shows **Logged Out**:
  - Check that the Fibre speed is set to **Automatic** or that the correct Fibre speed is selected. If you are unsure of the speed of the HBA or switch that the drive is connected to, try **Automatic**.
  - Check that the correct port type, **Fabric** or **Loop**, is selected. Loop requires additional configuration. If you are unsure of the correct port type, try **Automatic**.
- If the page shows **No Link**, the Speed Status is a dash (-), and the Link LED on the back of the drive is OFF, then the speed is probably set incorrectly. Try setting the speed to **Automatic**.

If there are still issues, change the port type to **Auto Detect**.

- If the page shows **No Light**:
  - The cable is not plugged in correctly. Check that it is connected correctly to Port A of the tape drive.
  - The cable is damaged. FC cables are delicate. If the cable has been bent or twisted sharply, it might be broken and must be replaced.
- If the page shows **ALPA Conflict**, there might be a conflict with the ALPA address on Loop ports.

Select **Soft** for the Loop mode to allow the system to select an available address each time the tape drive connects to the FC fabric. If your server configuration does not support changing addresses, try using the **Hard Auto-Select** option for the Loop mode. This allows the system to select an available address when it first connects, and then retain that address for future connections.

## Detection Problems After Installing a SAS Drive

Problems encountered after installation are often caused by either improper SAS cable connections, application software configuration errors, or an incorrectly configured operating system. If the application software or operating system does not communicate with the library after installation, determine the extent of the detection problem:

- Does the application software detect the tape drive?
- Does the application software detect the library?
- Does the operating system detect the tape drive?
- Does the operating system detect the library?
- Does the operating system detect the library, but list it as a generic device?

Based on the extent of the detection problem, check the following:

- If neither the application software nor operating system detects the tape drive, or they do not detect both the tape drive and the library:
  - Verify that all SAS cables are securely connected on both ends. If the mini-SAS connectors that connect to the tape drive (and some HBAs) will not plug in, check the key. The mini-SAS connector on the tape drive is keyed at location four, which is the standard location for end devices. If the connector on the cable is keyed in a different location, not only will the connector not plug in, but the cable probably will not work.
  - Check the length and integrity of your SAS cabling. For reliable operation, do not use a SAS cable longer than six meters. Do not use a cable adapter or converters between the HBA and the library.
  - Check the SAS connectors for damage or debris.
  - Verify that your HBA is supported by the host computer and qualified with the library.
  - Verify that your HBA has the latest firmware.

- If the application software or operating system detects the tape drive, but not the library:

Verify that multiple LUN support is enabled on the HBA. The library uses two Logical Unit Numbers (LUNs) to control the tape drive (LUN 0) and robotic (LUN 1). The library requires an HBA with multiple LUN support and multiple LUN support must be enabled on the host computer. When multiple LUN support is not enabled, the host computer can see the tape drive, but not the library.

**NOTE:** Many RAID or array controllers do not provide multiple LUN support.

- If the application software or operating system does not detect any devices on the HBA:
  - Verify that the SAS host adapter is installed correctly. Refer to the manual that came with your host adapter for installation and troubleshooting instructions. Pay particular attention to any steps describing configuration settings. Make sure that the host adapter is properly seated in the motherboard slot and the operating system correctly detects the host adapter.
  - Verify that the proper device driver is installed for the SAS host adapter.

- If the library is detected by the operating system, but not by the application software:

Refer to the documentation included with your backup application for instructions on how to verify proper installation. Some backup software packages require an additional module to communicate with the robotics.

- If the library is detected by the operating system, but is listed as an unknown or generic device:  
Make sure that the proper device driver, if applicable, is installed for the device. Check your software provider's website for the latest drivers and patches.

**NOTE:** Many backup applications use their own drivers. Before installing a driver, make sure it is not in conflict with the application software.

If you continue to have problems with a SAS library, check the following:

- Ensure that the library is compatible with the SAS host adapter and backup application you plan to use.
- Verify that your HBA is supported by the host computer and qualified with the library.
- Ensure you are using a compatible, high-quality cable.

## Operational Problems

### Power Problems

Problem	Solution
Device does not power on.	<ul style="list-style-type: none"> <li>• Check all power cord connections.</li> <li>• Check the LEDs on the power supplies to verify that they are working.</li> <li>• Make sure the power button on the front panel has been pressed, and the green <b>Ready</b> LED is lit.</li> <li>• Make sure the outlet has power. Try another working outlet.</li> <li>• Replace the power cord.</li> </ul>
No message appears on the OCP display.	<ul style="list-style-type: none"> <li>• Check all power cord connections.</li> <li>• Check the LEDs on the power supplies to verify that they are working.</li> <li>• Make sure the power button on the front panel has been pressed, and the green <b>Ready</b> LED is lit.</li> <li>• Make sure the outlet has power. Try another working outlet.</li> </ul>

### OCP Alerts and Errors

Problem	Solution
The OCP display is a warning or error icon.	Tap the icon to see more information about the event on the LCD.
The OCP displays an error code.	Look up the error code, try to resolve the failure, and power cycle the library (see <a href="#">Appendix B, "Event Codes and Acronyms"</a> ).

## Tape Movement Problems

Problem	Solution
Tape stuck in drive.	<p>Try the following steps, in this order, to remove the stuck tape.</p> <p><b>NOTE:</b> The tape drive must rewind the tape before ejecting it. This can take as long as five minutes, depending on how much tape must be rewound. Once the tape is rewound, the eject cycle will take fewer than 16 seconds.</p> <p>The <b>Ready</b> light flashes while the tape rewinds. Wait for the tape to finish rewinding before attempting another operation.</p> <p>Attempt to unload the tape from your backup software.</p> <p>Shut down the backup software and stop the operating system's removable storage services. From the <b>Operation &gt; Move Media</b> page, attempt to unload or move the tape to a slot.</p> <p>Power down the library, disconnect the cable from the drive, power up the library, and wait until the tape drive is idle or ready. From the <b>Operation &gt; Move Media</b> page, attempt to unload or move the tape to a slot.</p> <p>From the <b>Operation &gt; Force Drive Media Eject</b> page, attempt a force eject or emergency unload operation.</p> <hr/> <p> <b>IMPORTANT:</b> Inspect the tape cartridge that was stuck. Damage or misplaced labels on the cartridge could have caused the load/unload failure. Discard any tape cartridge found to have issues.</p>
Tape cannot be removed from storage slot.	<p>If the OCP or RMI is still operational:</p> <ol style="list-style-type: none"> <li>1. Unlock the magazine from the <b>Operation &gt; Open Magazine</b> page and open it to access the storage slot.</li> <li>2. Grasp the cartridge and remove it from the storage slot. Some tapes need to be inserted and removed several times to condition them for free movement in and out of the magazine.</li> <li>3. Check the barcode label and verify that it is secure to the cartridge.</li> <li>4. Check the cartridge for damage.</li> <li>5. Check the storage slot for damage.</li> </ol>

## Media Problems

Problem	Solution
Cleaning or data cartridge incompatible with drive.	<ul style="list-style-type: none"> <li>• Check the event log to see which cartridge is incompatible.</li> <li>• Make sure you are using data and cleaning cartridges that are compatible with the drive and model of your device and that you are using the correct cartridge type for the operation. The device automatically unloads incompatible cartridges, the <b>Attn</b> LED flashes. Export the media.</li> </ul>
Cannot write to or read from tape.	<ul style="list-style-type: none"> <li>• Make sure that the cartridge is not a WORM cartridge that has already been used.</li> <li>• Make sure that the cartridge is write enabled (move the write-protect switch to the enabled position).</li> <li>• Make sure the data cartridge is compatible with the drive model. LTO tape drives can read data cartridges from two generations back and write to data cartridges one generation back.</li> <li>• Make sure you are using an Ultrium cartridge that has not been degaussed. <b>Do not degauss Ultrium cartridges!</b></li> <li>• Make sure that the cartridge has not been exposed to harsh environmental or electrical conditions and is not physically damaged in any way.</li> <li>• Many backup applications do not read or write to cartridges that were created using a different backup application. In this case, you may have to perform an erase, format, or label operation on the cartridge.</li> <li>• Make sure you understand any data protection or overwrite protection schemes that your backup application may be using, which could prevent you from writing to a given cartridge.</li> <li>• Retry the operation with a different, known good tape.</li> <li>• Clean the tape drive from the <b>Operation &gt; Clean Drive</b> page.</li> </ul>

## Attn LED is Lit

Problem	Solution
Both the <b>Attn</b> and <b>Clean</b> LEDs are lit.	<p>This is most likely caused by a dirty drive that cannot read a tape and marks the tape invalid.</p> <p>Log into the OCP or RMI and check the event log to see which drive has reported that it needs cleaning. Clean the drive with an approved Ultrium cleaning cartridge.</p>
A particular cartridge triggers the <b>Clean</b> LED.	Remove the cartridge from the library.
A cartridge recently imported from a different environment is causing issues.	Media that is moved from one environment to another can cause issues until it has acclimated to the new conditions. A cartridge should be acclimated for at least 24 hours before being used, particularly if it has been stored at a substantially different temperature or level of humidity than the library.

Problem	Solution
The <b>Attn</b> LED is lit but the <b>Clean</b> LED is not lit after a cartridge load.	The library was unable to complete the requested operation with the selected tape cartridge. <ul style="list-style-type: none"> <li>Use only cartridges that are compatible with the drive type</li> <li>Use the correct type of cartridges for the operation. For example, use a cleaning cartridge for cleaning.</li> <li>Make sure you are using an Universal cleaning cartridge</li> </ul>
The <b>Attn</b> LED is lit but the <b>Clean</b> LED is not lit after a cartridge load.	The cleaning cartridge has expired. A cleaning cartridge expires after 50 cleaning cycles.
A particular cartridge sets off the <b>Attn</b> LED and possibly the <b>Clean</b> LED.	Retry the operation with a different cleaning cartridge. If the <b>Attn</b> LED is cleared and the drive has been cleaned, and then immediately re-displays each time a particular cartridge is reloaded, that cartridge should be suspected as being defective. <ul style="list-style-type: none"> <li>If this occurs, export the cartridge and load a known good cartridge. In some cases, a cartridge can be worn out, have a defective Cartridge</li> <li>Memory, or have been formatted as a Firmware Upgrade Cartridge.</li> <li>Any cartridge that is suspected of being defective or contaminated should NOT be reused in any drive.</li> <li>If the bad cartridge is a cleaning cartridge, it might be expired.</li> </ul>

## Inventory Problems

Problem	Solution
The library displays incorrect bar codes.	<ul style="list-style-type: none"> <li>Verify that the label is properly applied.</li> <li>Verify that the label is not soiled.</li> </ul>

## RMI Network Connection Problems

Problem	Solution
Cannot connect to the RMI.	<ul style="list-style-type: none"> <li>Verify that the Ethernet cable is connected to the Base Module's controller board management port and to the LAN.</li> <li>Verify that the link LED on the RJ45 (LAN) connector is lit when the device is powered up. If the LED is not lit, the device is not communicating with the LAN. See your network administrator for help.</li> <li>Verify that the device has been configured with a valid static network address or DHCP has been enabled so the device can obtain a network address. If using DHCP, write down the device's network address from the OCP login screen. If the device did not obtain a valid address via DHCP, verify that the DHCP server is up and the library has network access to it. If necessary, set a static network address instead.</li> <li>Enter the library's IP address into the address bar of a web browser connected to the same LAN as the device. If the RMI web page does not display, ping the device's IP address. If the ping fails, verify that the device has a valid network address and that there are no firewalls or other obstructions to network traffic between the computer with the web browser and the device. See your network administrator for help.</li> </ul>

## Cleaning Problems

Problem	Solution
Cannot load the cleaning cartridge.	<ul style="list-style-type: none"> <li>• Make sure you are using an Ultrium cleaning cartridge.</li> <li>• Make sure the cleaning cartridge has not expired. A cleaning cartridge expires after 50 cleaning cycles.</li> <li>• Power cycle the library.</li> </ul>

## Performance Problems

The process of backing up files involves many system components, from the files in the file system on the disk, through the backup server, and out to the library, all managed by software running on an operating system. The backup process can only run as fast as the slowest component in the system.

Performance issues are solved by identifying and addressing performance limitations in your system. See sections below for the following potential performance limitations:

- [Average File Size](#)
- [File Storage System](#)
- [Connection from the Backup/Archive Host Server to the Disk Array](#)
- [Backup/Archive Server](#)
- [Backup/Archive Software and Method](#)
- [Connection from the Archive/Backup Host Server to the Library](#)
- [Media](#)

### Average File Size

The hard drive must seek to the position of a file before it can start reading. The more time the disks are seeking to files, the lower the performance. Therefore, if the average file size is small, the read performance will be lower.

To determine the average file size, divide the size of the backup by the number of files.

If the average file size is small (64 KB or less), consider using a sequential, image, or block backup method that backs up the whole hard drive or LUN image instead of individual files. The trade off for using one of these methods is that you might only be able to restore the entire image instead of individual files.

**NOTE:** File fragmentation also causes excessive drive seeking, which lowers performance, so ensure that files are regularly defragmented.

### File Storage System

The file storage system determines the organization of the files on the disks. Using RAID controllers to spread files over multiple disks can improve performance because some disks can be seeking while others are reading. Storing files on a single non-RAID disk results in the slowest performance while storing files on a high-end disk array results in the fastest performance.

Converting standalone disks to RAID can improve performance.

## Connection from the Backup/Archive Host Server to the Disk Array

The connection between the host server and the disks determines how much data can be transferred from the disks to the host computer at a time. A connection with insufficient bandwidth cannot provide enough data for the tape drives to write at full speed. For optimum performance, the storage subsystem must be able to provide data at the tape drive's maximum transfer rate.

Backup systems using a lower speed Ethernet network should use multiple network connections.

## Backup/Archive Server

The backup server must have enough RAM and processor power to transfer the files from the disk to the tape drive, in addition to running the backup or archive software and any other processes.

Check the RAM and processor usage during a backup operation. If they are operating at capacity, adding more RAM or processor capability can improve performance.

## Backup/Archive Software and Method

Each backup method has its own impact on performance, depending on how well it can keep data streaming to the tape drive. In most cases, native applications don't have the features required to maximize performance for LTO tape drives. It is recommended to use a full-featured backup or archive application with this library.

File-by-file backup or archive methods provide the best restore performance if you only need to restore individual files. However, if the average file size is small, file-by-file methods will significantly reduce performance.

Disk image, flash, or sequential backup methods provide the fastest performance because they back up an entire disk, partition, or LUN, which minimizes disk seeking. The disadvantage is that backup and restore operations work on an entire disk, partition, or LUN. You might not be able to back up a subset of files or restore a single file. If you can restore a single file, the restore process will be slow.

Database backup performance varies based on the use model. To improve performance when backing up data from a database:

- Use specific backup agents for the database.
- Use the latest versions of the databases.
- Do not back up individual mailboxes.
- Do not back up specific records or do a record-by-record backup.
- Do not back up when the database is in heavy use.

## Connection from the Archive/Backup Host Server to the Library

For the best performance, the connection from the host server to the library must have enough bandwidth to provide enough data to keep the tape drive streaming. Current LTO tape drives take advantage of some of the fastest interfaces available so the type of interface used to connect the library to the host server is not likely to be the cause of a performance issue. However, issues with cables and connectors can limit performance.

Do not exceed recommended cable lengths.



## Media

The type and condition of the media also affect backup performance. For best performance, use media that is the same LTO generation as the tape drives.

## Finding Event Information

You can find error codes by viewing log files in the RMI from the **Maintenance > Logs and Traces > View Logs** page or downloading support tickets from the **Maintenance > Download Support Ticket** page. See [View Logs and Traces on page 104](#) or [Download Drive Logs on page 107](#) in [Chapter 6, "Remote Management Interface."](#)

## Unlocking a Magazine

It is recommended that you unlock a tape magazine using the unlock buttons or the RMI. If these methods fail, or if a magazine needs to be removed when the power to the device is off, you can release the magazine manually. Only one magazine can be open at a time.

**NOTE:** As a best practice, perform this procedure while applications are idle. While the magazine is extended, the library Robotic Assembly cannot move media.

For details see the following:

- [Using the Magazine Unlock Buttons](#)
- [Using the RMI to Unlock Magazines](#)
- [Using the Magazine Manual Release](#)

### Using the Magazine Unlock Buttons

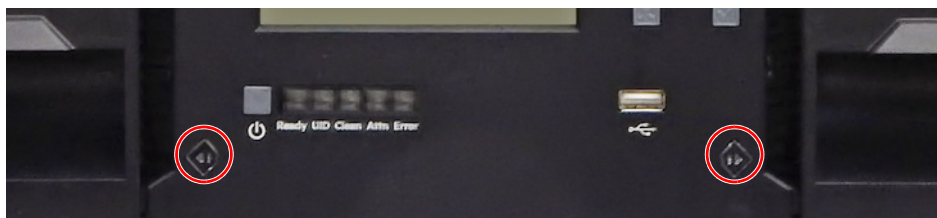

Press the magazine unlock button for more than three seconds. This starts the unlock operation for the magazine, indicated by the LED slowly flashing.

When the magazine is unlocked the LED starts quickly flashing.



**IMPORTANT:** Wait before pulling out the magazine until the LED is quickly flashing and OCP message says that the magazine is unlocked.

Pull out the magazine from the library. As soon as the magazine is pulled out, the LED switches OFF.

**NOTE:** Opening a magazine takes the library offline. The magazines relock after 30 seconds.

## Using the RMI to Unlock Magazines

Log in as an administrator.

On the Home page, click **Open Magazine**.



Click **Open** in the left or right magazine column within the module containing the magazine to be opened.

### Operation > Open Magazine

**NOTE:** Only one magazine is allowed to be removed at a time.

Module	Left	Right
Base	Closed <input type="button" value="Open"/>	Closed <input type="button" value="Open"/>

A message box indicates when the magazine has been unlocked.

Open Magazine page shows that the magazine is now unlocked.

**NOTE:** If not removed, the magazines and the mailslot relock after 30 seconds.

## Using the Magazine Manual Release



To manually release the magazine when the power is off, insert a small flat-head screwdriver or Torx driver into the appropriate magazine release hole and gently push the tab in.



**IMPORTANT:** Do not exert force once you encounter resistance. Doing so can damage the device.

## Unloading a Stuck Tape

If the tape is stuck in a tape drive, eject the tape from the drive from the **Operation > Force Drive Media Eject** page.

If a tape is stuck in a magazine, open the magazine, grasp the cartridge, and pull it out of the storage slot.

## Returning the Robotic Assembly to the Base Module

If you have powered off the library and the Robotic Assembly did not return to its park position in the Base Module behind the OCP:

1. Power on the library by pressing the **power button** on the Base Module just below the OCP.
2. From the RMI, return the Robotic Assembly to its park position using the **Maintenance > Move Robotic to Base Module** page.
3. Power off the library by pressing the **power button** on the Base Module and holding for three seconds.

If the Robotic Assembly is still not in the Base Module, use one of the procedures in the following two sections:

- [Robotic Assembly Stopped Near Base Module or Between Modules](#)
- [Robotic Assembly Stopped Far From Base Module or Cannot Move Vertically](#)

### Robotic Assembly Stopped Near Base Module or Between Modules

Remove the front bezel from the Base Module, the Expansion Module containing the Robotic Assembly, and any modules in between as needed. See [Replace the Base Module Front Bezel/OCP on page 157](#).

Insert a small flat-head screwdriver into the screwdriver relief on the right rear bearing block of the Robotic Assembly.

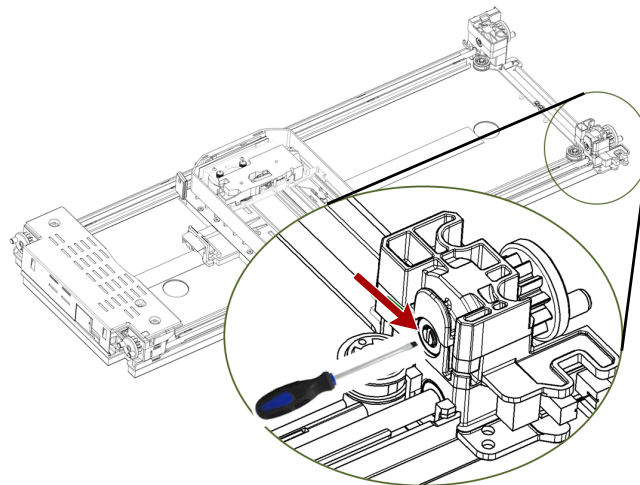

Turn the screwdriver to manually operate the Robotic Assembly gear train and move the Robotic Assembly into the Base Module.

Once the Robotic Assembly is inside the Base Module, lock it. Standing at the front of the module, you lock the Robotic Assembly by moving the blue lever to the left, then away from you, and then to the right.

Reinstall the bezels previously removed.

Replace the Robotic Assembly and Spooling Mechanism. See [Replace the Robotic Assembly and Spooling Mechanism](#) on page 146 in Chapter 7, "Service and Upgrades."

## Robotic Assembly Stopped Far From Base Module or Cannot Move Vertically

The library should already be powered off. Disconnect the power supply cables from all of the modules.

Manually unlock the left Base Module magazine using the manual release on the left side. Supporting the magazine on the bottom, remove the left magazine from the Base Module.

Using plastic-handled scissors, reach through the left magazine opening and carefully cut the spooling cable.

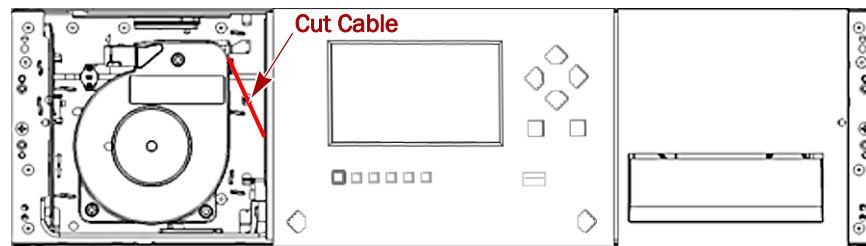

Replace the Robotic Assembly and Spooling Mechanism. See [Replace the Robotic Assembly and Spooling Mechanism](#) on page 146 in Chapter 7, "Service and Upgrades." Use these exceptions:

- Remove the Tape Magazines.
- Extend the Expansion Module containing the Robotic Assembly while carefully guiding the free spooling cable.
- Remove the Robotic Assembly from the Expansion Module and set it aside.
- Slide the Expansion Module back into the rack and secure it.
- Remove the Base Module per the instructions.
- Remove the old Spooling Mechanism from the Base Module.
- Install the new Robotic Assembly and Spooling Mechanism and complete the procedure.

## Running Library Tests

The library provides tests to verify library operations. The following tests are available in the RMI:

**NOTE:** The System, Slot-to-Slot, Robotics, and OCP tests are also available in the OCP.

- **System Test** – Exercises overall library functionality by moving cartridges within the library. Cartridges are returned to their original location. See [page 100](#).
- **Slot-to-Slot Test** – Randomly exchanges cartridges within the library. Cartridges are NOT returned to their original locations. See [page 100](#).

- **Element-to-Element Test** – Moves a cartridge to a specific element and then returns it to its original location. See [page 101](#).
- **Position Test** - Moves the Robotic Assembly vertically between two element locations. The test does not move cartridges. See [page 102](#).
- **Wellness Test** – Exercises a general health check on the library functionality by running the following partial tests:
  - **Basic Hardware Review**
  - **Robotics Initialization Test**
  - **Barcode Scanning Test**
  - **Move Media Test**See [page 103](#).
- **Robotic Test** – Exercises all Robotic Assembly movements and sensors. See [page 103](#).
- **OCP Test (with LCD Adjustment Reset)** – Illuminates each of the front panel LEDs and enables the OCP LCD contrast and brightness to be reset back to the defaults. See [page 104](#).

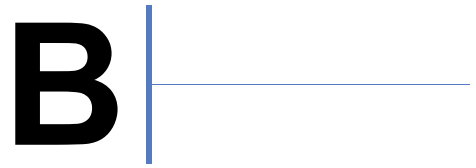

# Event Codes and Acronyms

This appendix details the event codes and key acronyms for the NEOxl 40 Tape Library.

## Topics in Event Codes and Acronyms:

- [Event Codes](#)
- [Warning Events](#)
- [Configuration Change Events](#)
- [Informational Events](#)
- [Acronyms and Abbreviations](#)

## Event Codes

Event Code	Message Text and Description	Details and Solution
2000	Failed to move cartridge.	Verify the source and destination elements and retry the move operation.
2002	The initial module discovery (detection of expansion modules) failed.	Verify that all expansion modules are powered on and that the expansion interconnect cables are properly installed.
2003	The library's temperature has exceeded the critical limit.	Check to ensure: <ul style="list-style-type: none"><li>• The chassis fan is functioning in each module present.</li><li>• The drive cover plates are installed where no drive exists.</li><li>• All power supplies are installed.</li><li>• The ambient room temperature is within limits.</li></ul>
2004	Library Startup Failure.	Verify that magazines are closed, cartridges are fully seated, and that there are no Robotic Assembly obstructions. Verify all modules are powered and any expansion modules are cabled correctly with the inter module cable. Verify there is a top and bottom cover properly installed on the library. Also, verify the module alignment locks (at rear of module) are in the proper position. If the robot moves front to back, but not vertically, the robot shipping lock could be positioned incorrectly and should be moved to either the fully locked or fully unlocked position. If the error persists, review library events for more information and/or reboot the library.
2005	Robotic spooling cable failure.	Ensure that the spooling cable is fully seated in the base module and connected correctly to the Robotic Assembly.
2006	Cable to Spooling Mechanism has failed.	Ensure that the Spooling Mechanism is fully seated in the base module and connected correctly to the Robotic Assembly.

Event Code	Message Text and Description	Details and Solution
2009	Library test failed due to Robotic Assembly problem.	Review test requirements and retry the test, if the test continues to fail check for robotic obstructions or other robotic problems. For proper operation the robot must be able to reach the very bottom of the library. Verify there are no obstructions at the bottom of the library or on the bottom cover of the library in the path of the robot. To check for obstructions at the bottom of the library, first power off the library by pressing the front power button for 5 seconds and select the Default Park location. Once the library is powered off, remove the left magazine of the lowest library module, and verify the entire area of the bottom cover is free of any objects that might obstruct the robot's path. After clearing any obstructions, replace the magazine, power the library on, and after the library finishes initialization and inventory, verify no further critical events were generated.
2010	Library test failed due to Spooling Mechanism defect.	Ensure that the Spooling Mechanism is fully seated in the base module and installed correctly to the Robotic Assembly.
2011	Drive Power Board has failed. Due to this failure some drives maybe powered off.	Ensure the Drive Power Board is fully seated in the module and power cycle the library.
2012	Multiple bottom covers detected.	Remove all bottom covers except from the bottom module in the library.
2013	Multiple top covers detected.	Remove all top covers except for the top module in the library.
2014	Bottom cover is missing.	Install the bottom cover on the bottom module of the library, also check the module interconnect cabling and module power cabling. If the base module cannot detect both a top and bottom cover, the robot will not move.
2015	Top cover is missing.	Install the top cover on the top module of the library, also check the module interconnect cabling and module power cabling. If the base module cannot detect both a top and bottom cover, the robot will not move.
2016	Module alignment mechanism is not locked properly.	Ensure that the alignment mechanism is engaged in every module that is above another module in the library.
2017	A communication problem between modules was detected.	Ensure that all modules are powered and have the inter connect cable properly attached. Also, ensure that the module alignment locks (located at the rear of module) are in the correct positions.
2018	Too many unit position transmitter/detector failures.	Ensure that the alignment mechanism is engaged in every module that is above another module in the library. Perform a power cycle.
2021	Database access error.	Restore a configuration backup and perform a power cycle.
2022	Drive has been hot removed while in active status as LUN master.	Reinsert the removed drive at the same position as it was removed.
2023	Internal software error.	Check for a new system software version for upgrade.
2024	Exception thrown by application not handled.	Check for a new system software version for upgrade.

Event Code	Message Text and Description	Details and Solution
2027	Move failed pulling cartridge from slot.	Check for labels or cartridge misalignments that would prevent the cartridge from coming out of the slot or drive. For proper operation the robot must be able to reach the very bottom of the library. Verify there are no obstructions at the bottom of the library or on the bottom cover of the library in the path of the robot. To check for obstructions at the bottom of the library, first power off the library by pressing the front power button for 5 seconds and select the Default Park location. Once the library is powered off, remove the left magazine of the lowest library module, and verify the entire area of the bottom cover is free of any objects that might obstruct the robot's path. After clearing any obstructions, replace the magazine, power the library on, and after the library finishes initialization and inventory, verify no further critical events were generated.
2028	Move failed inserting cartridge to slot.	Check for labels or cartridge misalignments that would prevent the cartridge from moving into the slot or drive. For proper operation the robot must be able to reach the very bottom of the library. Verify there are no obstructions at the bottom of the library or on the bottom cover of the library in the path of the robot. To check for obstructions at the bottom of the library, first power off the library by pressing the front power button for 5 seconds and select the Default Park location. Once the library is powered off, remove the left magazine of the lowest library module, and verify the entire area of the bottom cover is free of any objects that might obstruct the robot's path. After clearing any obstructions, replace the magazine, power the library on, and after the library finishes initialization and inventory, verify no further critical events were generated.
2029	Initialization failure due to robot front to back positioning error.	Check for obstructions in the pathway of the robot such as a cartridge sticking out. Verify module alignment and frame alignment. Check if Robotic Assembly stuck in lock mechanism, move Robotic Assembly apart from lock mechanism and enable lock mechanism correctly.
2032	Initialization failure due to robot rotation positioning error.	Check for obstructions in the vertical pathway of the robot such as a cartridge sitting in the shuttle of the robot or any other impedance to robotic movement.
2033	Initialization failure due to robot vertical positioning error.	Check for obstructions in the vertical pathway of the robot such as a cartridge sticking out. Verify module alignment and frame alignment. For proper operation the robot must be able to reach the very bottom of the library. Verify there are no obstructions at the bottom of the library or on the bottom cover of the library in the path of the robot. To check for obstructions at the bottom of the library, first power off the library by pressing the front power button for 5 seconds and select the Default Park location. Once the library is powered off, remove the left magazine of the lowest library module, and verify the entire area of the bottom cover is free of any objects that might obstruct the robot's path. After clearing any obstructions, replace the magazine, power the library on, and after the library finishes initialization and inventory, verify no further critical events were generated.
2034	Cable to Spooling Mechanism has failed during initialization.	Ensure that the Spooling Mechanism is fully seated in the base module and connected correctly to the Robotic Assembly.
2035	Initialization failure due to robot gripper positioning error.	Check for obstructions in the vertical pathway of the robot such as a cartridge sitting in the shuttle of the robot or any other impedance to robotic movement.
2036	Unintended termination of application process.	Reboot or power cycle system.
2037	Robotics firmware version upgrade failed.	Reboot or power cycle system.



Event Code	Message Text and Description	Details and Solution
2038	Lost connection to Module.	Ensure that all modules are powered and have the interconnect cable properly attached. Reboot or power cycle the system.
2039	Cartridge left in robot gripper, unable to be moved to any open location.	Enable Mailslots and ensure that some of them are free. Then power cycle library. If still failing, open covers and remove cartridge manually from gripper.
2040	Wellness test failed with critical error.	
2041	Wellness test failed because of unit lock failed.	Ensure that the alignment mechanism is engaged in every module that is above another module in the library.
2042	Wellness test failed because top cover is missing.	Install the top cover on the top module of the library, also check the module interconnect cabling and module power cabling. If the base module cannot detect both a top and bottom cover, the robot will not move.
2043	Wellness test failed because bottom cover is missing.	Install the bottom cover on the bottom module of the library, also check the module interconnect cabling and module power cabling. If the Base Module cannot detect both a top and bottom cover, the robot will not move.
2044	Wellness test failed because Drive Power Board has failed.	Ensure the Drive Power Board is fully seated in the module and power cycle the library.
2045	Wellness test failed because move media test failed.	The minimum requirements for the Wellness are at least one unloaded drive and one data cartridge compatible with that unloaded drive installed in the library. If no drives are unloaded or no compatible media is found, the test fails and an error event will be generated. To view event details from RMI, click on the event, and then view all of the event details to see what elements were involved in the move failure. Additionally, check for obstructions in the pathway of the robot such as a cartridge sticking out. Verify module alignment and frame alignment. Check if Robotic Assembly stuck in lock mechanism, move Robotic Assembly apart from lock mechanism and enable lock mechanism correctly.
2046	Wellness test failed because drive communication test failed.	Remove and reseal the drive canister to ensure that the drive is fully seated. If the issue persists then reset the drive. Use the library RMI to pull a drive support ticket and check the device analysis section for more help (HPE Library and Tape Tools must be installed to view support ticket).
2047	Wellness test failed because the barcode scanning test failed.	Verify that there is no obstruction in front of the barcode scanning module on the cartridge table located on the Robotic Assembly. If the error persists replace the Robotic Assembly. For proper operation the robot must be able to reach the very bottom of the library. Verify there are no obstructions at the bottom of the library or on the bottom cover of the library in the path of the robot. To check for obstructions at the bottom of the library, first power off the library by pressing the front power button for 5 seconds and select the Default Park location. Once the library is powered off, remove the left magazine of the lowest library module, and verify the entire area of the bottom cover is free of any objects that might obstruct the robot's path. After clearing any obstructions, replace the magazine, power the library on, and after the library finishes initialization and inventory, verify no further critical events were generated.
2051	Wellness test failed because of the failing robotic test.	Check for obstructions in the pathway of the robot such as a cartridge sticking out. Verify module alignment and frame alignment. Check if Robotic Assembly stuck in lock mechanism, move Robotic Assembly apart from lock mechanism and enable lock mechanism correctly. Ensure that the spooling cable is fully seated in the Base Module and connected correctly to the Robotic Assembly.

Event Code	Message Text and Description	Details and Solution
2052	An open magazine was detected in one or more modules and as a result the system was taken offline.	Ensure that all magazines are completely inserted and properly locked. Do not open magazines using the emergency release while the library is operating and the robot is moving.
2053	An open top cover was detected and as a result the system was taken offline.	Ensure that the top cover is completely inserted and properly locked. Do not open top cover using the emergency release while the library is operating and the robot is moving.
2054	An open bottom cover was detected and as a result the system was taken offline.	Ensure that the bottom cover is completely inserted and properly locked. Do not open bottom cover using the emergency release while the library is operating and the robot is moving.
2055	An open unit lock was detected and as a result the system was taken offline.	Ensure that all unit locks are properly locked. Do not open unit locks using the emergency release while the library is operating and the robot is moving.
2056	Initialization failure due to picker push pull positioning error.	Check for obstructions in the horizontal pathway of the Robotic Assembly such as a cartridge sticking out or a cable impeding progress.
2057	Robotics shipping lock in incorrect position.	Get access to the picker assembly and manually move the shipping lock lever to either locked or unlocked position. After moving the shipping lock to the one of the correct positions, reboot the library.
2061	Move failed pulling cartridge from drive.	Check for labels or cartridge misalignments that would prevent the cartridge from coming out of the drive.
2062	Move failed inserting cartridge to drive.	Check for labels or cartridge misalignments that would prevent the cartridge from coming out of the drive.
2063	Move failed positioning picker in front of drive.	Check for obstructions in the vertical or horizontal pathway of the Robotic Assembly. Examples could include a cartridge that is not seated completely in a slot, a Robotic Assembly is not sitting horizontally level, or a problem with the robotic spooling cable that is impeding progress.
2064	Library test failed with critical error.	
2065	Library startup process failed because of robotics initialization issue.	
2066	Library startup process failed during inventory scan.	
2067	For safety reason the robot movement was halted in place.	Ensure that all magazines, top or bottom covers and unit locks are completely inserted and properly locked. Do not open magazines using the emergency release or remove covers or unit locks while the library is operating and the robot is moving. Ensure that all modules are powered and have the inter connect cable properly attached.
2068	An emergency stop condition was detected in one or more modules and prevented the robotic from initialization.	Ensure that all magazines, top or bottom covers and unit locks are completely inserted and properly locked. Please insert all open magazines and install all necessary covers and unit locks before powering on the library. Ensure that all modules are powered and have the inter connect cable properly attached.
2069	Initialization failure due to barcode reader error.	

Event Code	Message Text and Description	Details and Solution
2070	Inventory scan failed because of Elevator axis problem.	Check for obstructions in the vertical pathway of the robot such as a cartridge sticking out. Verify module alignment and frame alignment. For proper operation the robot must be able to reach the very bottom of the library. Verify there are no obstructions at the bottom of the library or on the bottom cover of the library in the path of the robot. To check for obstructions at the bottom of the library, first power off the library by pressing the front power button for 5 seconds and select the Default Park location. Once the library is powered off, remove the left magazine of the lowest library module, and verify the entire area of the bottom cover is free of any objects that might obstruct the robot's path. After clearing any obstructions, replace the magazine, power the library on, and after the library finishes initialization and inventory, verify no further critical events were generated.
2071	Cartridge on picker when trying to scan.	Verify that there is no obstruction in front of the barcode scanning module on the cartridge table located on the Robotic Assembly. If the error persists replace the Robotic Assembly.
2072	Bottom cover detected at an incorrect position.	Review the stack assembly and place the covers to the proper position.
2073	Top cover detected at an incorrect position.	Review the stack assembly and place the covers to the proper position.
2074	The library startup failed due to a GPIO error.	Reboot or power cycle system.
2075	The library startup failed due to an error when trying to open the robotics serial port.	Reboot or power cycle system.
2076	I2C bus signals invalid.	Remove all drive canisters of the affected chassis and reboot the library. If the problem persists, replace the chassis. If not, add one drive after the other until the problem comes back. Replace the last drive added before it failed again.
2077	Failed to store Calibration Data to Chassis.	Reboot or power cycle system.
2078	Incompatible Robotic Assembly without Encoder detected.	Replace Robotic Assembly with a compatible model with Encoder or upgrade Firmware to a version which supports Encoder-less control.
2079	Could not upgrade barcode reader firmware.	Reboot the library and if the error persists replace the robotics.
2080	Cartridge lost while inserting it into slot/drive.	Check the source/destination element and ensure that there are no obstructions in the pathway of the robot.
2081	I2C port expander read write error.	Reboot the library and if the error persists replace the chassis. Prior to replacing the chassis, ensure you remove all of your tape cartridges. If magazines need to be removed to get access to the tape cartridges, first power down the device and then manually release each magazine. Only one magazine should ever be opened at a time.
2083	Drive Power Board is not compatible to this Library and does not match to the installed power supply.	Remove incompatible Drive Power Board. Only install Drive Power Boards that are compatible with the library.
2084	Lost connection to Module, possibly due to abnormal network activity.	Ensure that all modules are powered and have the inter-connect cable properly attached. If this event is seen on multiple modules or after ensuring all inter-connect cables are properly attached, also ensure that the network that the Base Module is connected to is not experiencing broadcast storms or other abnormal activity. Reboot or power cycle the system to re-discover the modules.

Event Code	Message Text and Description	Details and Solution
2085	Communication failure to the Base Module controller board I2C port expander component.	Until this issue is resolved, the base module will not be able to discover any attached expansion modules. Reboot the library to see if the error persists. If the error persists, power off the library and reseal the base module controller. If the error continues to persist, replace the base module controller.
2086	Communication failure to the Expansion Module controller board I2C port expander component.	Until this issue is resolved, the base module will not be able to discover any attached expansion modules. Reboot the library to see if the error persists. If the error persists, power off the library and reseal the expansion module controller. If the error continues to persist, replace the expansion module controller.
2087	Error accessing the backplane flash memory.	Reboot the library and if the error persists replace the chassis. Prior to replacing the chassis, ensure you remove all of your tape cartridges. If magazines need to be removed to get access to the tape cartridges, first power down the device and then manually release each magazine. Only one magazine should ever be opened at a time.
2088	Failure moving to the lowest vertical position of the library, check for obstructions on the bottom cover.	<p>For proper operation the robot must be able to reach the very bottom of the library. Verify there are no obstructions at the bottom of the library or on the bottom cover of the library in the path of the robot.</p> <p>To check for obstructions at the bottom of the library, first power off the library by pressing the front power button for 5 seconds and select the Default Park location.</p> <p>Once the library is powered off, remove the left magazine of the lowest library module, and verify the entire area of the bottom cover is free of any objects that might obstruct the robot's path.</p> <p>After clearing any obstructions, replace the magazine, power the library on, and after the library finishes initialization and inventory, verify no further critical events were generated.</p>
2089	Incompatible Robotic Assembly detected.	An incompatible Robotic Assembly has been detected. The Robotic Assembly was not powered on to avoid damage of the library. Power off the library and replace the Robotic Assembly with a compatible version.
2090	Wellness test failed because incompatible Drive Power Board detected.	Remove incompatible Drive Power Board. Only install Drive Power Boards that are compatible with the library.
2091	Display Controller of the Operator Control Panel (OCP) reports an error	Reboot the library for new initialization of the OCP controller. If the error continues to persist, replace the Operator Control Panel.

## Warning Events

Event Code	Message Text and Description	Details and Solution
4000	A reported drive canister fan speed is too slow.	Ensure there are no obstructions in the fan
4002	A drive sent a clean request.	Clean the drive with an approved cleaning cartridge.
4003	The drive configuration failed.	Remove and reseal the drive canister and retry the operation. If the drive installed is a different generation than the drive previously installed, you may need to reset defaults and reconfigure the drive as appropriate. Use the library RMI to pull a drive support ticket and check the device analysis section for more help (HPE Library and Tape Tools must be installed to view support ticket).

Event Code	Message Text and Description	Details and Solution
4004	The drive status request failed.	Remove and reseal the drive canister to ensure that the drive is fully seated. If the issue persists then reset the drive. Use the library RMI to pull a drive support ticket and check the device analysis section for more help (HPE Library and Tape Tools must be installed to view support ticket).
4005	Drive is reporting a critical TapeAlert.	Power-cycle the drive, and verify whether the drive reports the same TapeAlert. Use the library RMI to pull a drive support ticket and check the device analysis section for more help (HPE Library and Tape Tools must be installed to view support ticket).
4006	A drive temperature reported is above the threshold.	Verify the drive fan is spinning, is not obstructed and that the ambient temperature is within specification. Also, ensure that there are drive bay cover plates in place in each location where there is no drive installed. The drive cover plates are required for proper airflow.
4007	Cartridge error.	Remove the cartridge and inspect it for damage. Retry operation with another cartridge.
4008	Cleaning tape expired.	Discard the cleaning cartridge and retry the cleaning operation with a new cleaning cartridge.
4009	Firmware upgrade of one or multiple expansion modules failed.	The Base Module must be able to communicate with a powered on and connected expansion module to perform the upgrade. Reseat the expansion controller and check the inter module cable and power connections. Retry the firmware upgrade.
4010	Drive is not compatible with this library.	Remove the incompatible drive. Only install drives that are supported by the library.
4012	Move Cartridge operation failed due to drive or media issue.	View the event details to determine which cartridge was involved. Verify surrounding events pointing to problems with this media in other move operations. Remove the media from the library, and physically inspect the media to ensure there is no physical damage. If the media appears to be undamaged, put the media back into the library and retry the move operation. If the problem persists retry the operation with a different cartridge in the same drive. If the problem follows the media, remove the media from use. If the problem follows the drive, use the library RMI to pull a drive dump and contact Technical Support.
4014	Library test failed due to a drive issue.	Verify the test parameters, and retry the test. If the test fails, check the library event log for specific events associated with this drive. Use the library RMI to pull a drive dump and contact Technical Support.
4015	Power supply has failed. Redundancy is not available.	Ensure all power supplies are installed properly (two per module), and that each power supply is connected to a valid power source.
4016	Backup configuration data to base module failed.	Attempt to save a library configuration, power cycle the library and retry the operation.
4017	Restore configuration data from Chassis failed.	Attempt to save a library configuration, power cycle the library and retry the operation.
4018	Firmware upgrade failed, tape drive reported an error applying the firmware file.	Verify that the firmware file is correct for the drive(s), ensure the drives are in a healthy state with no cartridge in the drive, then retry the operation.
4019	General Drive Firmware bundle upgrade failure.	Verify that the firmware file is correct for the drive(s), ensure the drive is in a healthy state with no cartridge in the drive, then retry the operation.
4020	Database has been reset due to a problem that prevented the library from powering up.	If the library was restored to default settings, restore a saved configuration by using a previously saved configuration file. If a configuration file does not exist, then proceed in configuring the library.

Event Code	Message Text and Description	Details and Solution
4021	Drive has been hot removed while in active status as data transfer device.	
4024	One or two unit position transmitter/detector failures.	
4025	Library test failed due to a cartridge error.	Remove the cartridge and inspect it for damage. Retry operation with another cartridge.
4028	Drive cannot use this media due to it being an unknown or unsupported format. Possibly the media is the wrong generation of media.	Check LTO generation for media and drives. Remove cartridges which are not compatible to your tape drives.
4029	Incompatible media move operation blocked by media barcode ID check.	Check if Media barcode label is matching LTO generation. Replace label or remove incompatible media from your system.
4030	Move cartridge operation failed due to media error.	Remove the cartridge and inspect it for damage. Retry operation with another cartridge.
4033	Unsupported KeyGenPolicy.	Check network connection and ESKM server configuration for the specified partition. Ensure that all partitions on the library have a valid KeyGenPolicy on the ESKM server. After ensuring that all partitions have a matching KeyGenPolicy, re-run the partitioning wizard for the specified partition. Use the <b>Status &gt; Security</b> page to verify all drives and partitions are configured correctly for encryption.
4041	Wellness test failed because of power supply redundancy test failed.	Ensure all power supplies are installed properly (two per module), and that each power supply is connected to a valid power source.
4044	One of the Library tests failed because of a source element or destination element is currently not accessible.	
4059	A drive that does not support encryption is configured in a partition with encryption enabled.	Replace Drive by a model of LTO generation 4 or higher or disable encryption for this partition.
4060	Connection to the KMIP server failed.	Verify user name and password as well as all needed SSL certificates needed for connecting to the KMIP server. Verify that the KMIP server is reachable within the network.
4061	Key not found on KMIP server.	Verify that the requested key is available on the KMIP server. Check the KMIP server logs for additional details.
4062	Key creation on KMIP server failed.	Check the KMIP server logs for additional details about why key creation failed.
4063	KMIP configuration invalid.	Use the KMIP configuration wizard to verify the KMIP configuration.
4064	KMIP feature not licensed.	Disable KMIP or install appropriate license for KMIP feature.
4065	A tape alert flag was reported by a drive.	
4067	Cleaning cartridge will soon expire and should be replaced.	Replace the cartridge.
4068	No cleaning cartridge found.	Auto cleaning is enabled, but the library contains no labeled cleaning cartridge. The library was unable to perform the auto clean function for one or more drives. Install a valid and labeled cleaning cartridge and then perform a load and unload on the drive that needs cleaned to initiate the auto cleaning.

Event Code	Message Text and Description	Details and Solution
4071	Power supply fan failed.	Verify the power supply fan is spinning and ensure there are no obstructions in the fan.
4072	No cleaning cartridge in partition available for auto cleaning.	Auto cleaning is enabled, but the partition contains no labeled cleaning cartridge. The library was unable to perform the auto clean function for one or more drives in this partition. Install a valid and labeled cleaning cartridge into the partition and then perform a load and unload on the drive that needs cleaned to initiate the auto cleaning.
4073	Medium source element empty.	Check the source slot visually and rescan inventory. Additionally check for valid and readable barcode label.
4074	Medium source element empty.	Check the source slot visually and rescan inventory. Additionally check for valid and readable barcode label.
4075	Cartridge lost while extracting it from slot/drive.	Check the source/destination element and ensure that there are no obstructions in the pathway of the robot.
4077	Unlocking the right magazine failed.	Reboot the library and retry the operation. If the error persists replace the chassis. If the magazine needs to be removed to get access to the tape cartridges, first power down the device and then release the magazine manually. Only one magazine can be open at a time.
4078	Unlocking the left magazine failed.	Reboot the library and retry the operation. If the error persists replace the chassis. If the magazine needs to be removed to get access to the tape cartridges, first power down the device and then release the magazine manually. Only one magazine can be open at a time.
4079	Unlocking the mailslot failed.	Reboot the library and retry the operation. If the error persists replace the chassis. If the mailslot needs to be removed to get access to the tape cartridges, first power down the device and then release the entire magazine manually. Only one magazine can be open at a time.
4080	Wellness test failed with warning.	
4083	Library not properly calibrated. This may cause media movement failures.	The library needs to be re-calibrated. Ensure the library firmware is up to date. If this event persists after a reboot of the library, or if calibration does not begin automatically upon restart, manually initiate calibration via the Maintenance > Auto Calibration RMI menu.
4085	Too many retries of drive command needed because of Unit Attention or Not Ready condition.	
4086	Move operation failed due to the inability accessing the database.	Ensure the network the library is connected to is operating normally and ensure the library is running the latest firmware. Library needs reboot.
4088	Library not properly calibrated. This may cause media movement failures.	Some chassis calibration data does not match to installed robot. Please reboot the library to initiate a re-calibration of the system. Ensure the library firmware is up to date. If this event persists after a reboot of the library, or if calibration does not begin automatically upon restart, manually initiate calibration via the Maintenance > Auto Calibration RMI menu.
4089	Auto calibration of one or more modules failed. Library not properly calibrated. This may cause media movement failures.	The library needs to be re-calibrated. Ensure the library firmware is up to date. This event indicates that one or more of the gray calibration targets located on the library magazines could not be used in calibration. Inspect the calibration targets in each module and then repeat the auto-calibration routine via the Maintenance > Auto Calibration RMI menu.
4090	Auto calibration of one or more modules failed. Library not properly calibrated. This may cause media movement failures.	The library needs to be re-calibrated. Ensure the library firmware is up to date. This event indicates that one or more of the gray calibration targets located on the library magazines could not be used in calibration. Inspect the calibration targets in each module and then repeat the auto-calibration routine via the Maintenance > Auto Calibration RMI menu.



Event Code	Message Text and Description	Details and Solution
4091	Auto calibration of one or more modules failed. Library not properly calibrated. This may cause media movement failures.	The library needs to be re-calibrated. Ensure the library firmware is up to date. This event indicates that one or more of the gray calibration targets located on the library magazines could not be used in calibration. Inspect the calibration targets in each module and then repeat the auto-calibration routine via the Maintenance > Auto Calibration RMI menu.
4092	Installed robotic does not support auto calibration.	If move errors are occurring, the Robotic Assembly needs to be replaced with a robot that supports auto-calibration. If this event persists after replacing the robot, manually initiate calibration via the Maintenance > Auto Calibration RMI menu.
4093	Could not obtain an IP address from DHCP server.	Check the network configuration settings and check if the DHCP server is reachable. Use the network configuration menu or unplug the network cable and plug it in after a few seconds to trigger an automatic reconfiguration of the network interface.
4094	Drive interface I/O error.	Reboot the library for new initialization of hardware and device drivers. Get in touch with service if the problem persists.
4095	Library test failed. Not enough valid cartridges available for testing.	
4097	Drive port configured to NPIV but failed to negotiate with Fibre channel switch.	Verify that your Fibre channel switch is supporting NPIV and that this option is enabled for the port connected to the failing tape drive. Note: It may be necessary to disconnect and reconnect the port after changing NPIV configuration of the switch. Disable control path failover if NPIV can't be supported by your infrastructure.
4098	System time synchronization via SNTP failed.	Check for valid SNTP server address in Time configuration. If correct, ensure that server reachable from your network and not blocked by Firewall.
4099	An unexpected reset of robotics has been detected.	Ensure that the spooling cable is fully seated in the Base Module and connected correctly to the Robotic Assembly. If the error re-occurs replace the Robotic Assembly.
4110	Drive disabled due to an incompatible Drive Power Board.	Remove incompatible Drive Power Board. Only install Drive Power Boards that are compatible with the library.
4113	Move Cartridge operation failed due to cartridge not properly taken over from Drive.	Check for labels or cartridge misalignments that would prevent the cartridge from coming out of the slot or drive.
4117	Drive disabled because no power supply available in this module.	Remove all affected Drives, insert and power up at least one power supply to the failing module. Wait ten seconds and put the drives back into the module.
4118	Drive disabled because no Drive Power Board available in this module.	Power down your library stack. Install compatible Drive Power Board to the failing module. Restart library stack.
4119	Drive disabled because internal IP address for communication unknown.	Remove affected drive, wait ten seconds and put it back into the module. Alternatively reboot Library stack.
4120	No empty drive available for system test.	
4121	No compatible media available for system test.	
4122	No cartridge available for slot to slot test.	
4123	No empty slot available for slot to slot test.	



Event Code	Message Text and Description	Details and Solution
4124	Drive or media statistics could not be retrieved when unloading the tape.	Check for additional warning tickets. Replace media if media related tape alert flags reported.
4125	Potential conflict: Tape drive has been accessed by multiple initiators.	Multiple SCSI command initiators were detected on a drive, in a partition that has multi-initiator conflict detection enabled (LT07 or newer feature). View the list of host WWNN addresses listed in this event and take action to prevent host access for any host WWNN you do not want accessing the tape drive. Once all of the other host WWNNs are prevented from accessing the tape drive, close the event and continue normal use of the tape drive.
4126	Cartridge found in inaccessible slot of lowermost unit.	
4127	Drive has been restarted because of canister reset.	
4128	An expansion module has detected an installed power supply but this power supply does not provide power.	Ensure the power supply has a power cord plugged in and is connected to a valid power source. Although power source is not available this expansion module can still be used for tape storage. Operation of tape drives is not possible.
4129	Media removal prevented by drive.	Check backup application how to allow media removal from drive. If unsuccessful try Force Drive Media Eject option in operations menu.
4130	Wellness test failed because drive not finally initialized.	Wait until drive initialization completed and run test again.
4131	Wellness test failed because drive installed to a module without power supply.	Install at least one power supply to the module where the failing drive is located or move the drive to a module with power supply.
4132	Wellness test failed because serial drive installed to a module without Drive Power Board.	Install Drive Power Board to the module where the failing drive is located or move the drive to a module with Drive Power Board installed.

## Configuration Change Events

Event Code	Message Text and Description
8000	The configuration of a drive changed.
8001	The drive was added or removed from the system.
8002	A partition was added/removed or changed.
8003	A mailslot bank was enabled / disabled.
8004	Drive firmware changed due to firmware upgrade.
8006	The email configuration settings have been changed.
8007	The configuration of a date/time format changed.
8008	The system language setting changed.
8009	The timezone configuration has changed.
8010	A new partition was added.
8011	The network settings have changed.

Event Code	Message Text and Description
8012	All Expansion Modules upgraded.
8013	The NTP time synchronization configuration has changed.
8014	The SSH access was enabled/disabled.
8015	Level of media generation checking has changed.
8016	Library reset default settings invoked by user.
8017	Library FW changed.
8018	The Unlabeled Media Support configuration has changed.
8019	Robotics firmware version upgraded.
8022	RMI/OCP Timeout configuration changed.
8024	Mailslot / Magazine access control configuration changed.
8025	Mailslot / Magazine automatic re-lock duration changed.
8026	Robotics change detected.
8029	The SNMP configuration changed.
8030	A SNMP target has been added.
8031	A SNMP target has been deleted.
8032	The SNMPv3 settings changed.
8033	The OCP module has been changed.
8034	A drive reboot has been requested by RMI command or REST interface. This process could cause side effects if done in parallel to running operations.
8035	Chassis calibration data has been changed.
8036	New chassis detected.
8037	Chassis has been removed.
8040	LDAP Server has been added.
8041	LDAP Server has been modified.
8042	LDAP Server has been deleted.
8043	LDAP User has been added.
8044	LDAP User has been modified.
8045	LDAP User has been deleted.
8046	Logout prevention configuration changed.
8057	New hardware component added to the Library.
8058	Hardware component removed from the Library.
8059	Hardware component of Library replaced.
8060	New Expansion Controller detected.
8061	New Base Library Controller detected.

## Informational Events

Event Code	Message Text and Description
9000	A tape alert flag was reported by a drive.
9001	A drive is present in the system but powered off.
9002	The library was powered on.
9003	Move Medium command was executed.
9004	Inventory scan was performed.
9005	The library was powered down from Front Panel.
9006	The network interface was switched on.
9007	The network interface switched off.
9008	The System Time was synchronized with a NTP server.
9009	A magazine was unlocked and opened.
9010	A magazine was closed and locked.
9011	A mailslot bank was unlocked and opened.
9012	A mailslot bank was closed and locked.
9013	A user logged in at the RMI interface.
9014	A user logged out at the RMI interface.
9015	A user logged in at the OCP interface.
9016	A user logged out at the OCP interface.
9020	The MSL Encryption Kit password has been set.
9024	Drive support ticket created.
9025	Library test started.
9026	Library test successfully finished.
9027	Library test stopped by user.
9028	Configuration backup to Base Module was successful.
9029	Configuration restore from Base Module was successful.
9031	Library health Status changed to "Status OK".
9032	Library health status changed to status "Warning".
9033	Library health status changed to status "Critical".
9034	New system controller detected.
9035	New library chassis detected.
9037	The library was rebooted.
9038	The library was rebooted through user interface.
9041	Key on KMIP server created.

Event Code	Message Text and Description
9043	Drive cleaning.
9045	Library configuration data failed to duplicate on to the Base Module.
9058	Power supply fan failed.
9060	One or multiple configured DNS servers are not responding.

## Acronyms and Abbreviations

Acronym	Meaning
FC	Fibre Channel
FH	Full Height
GUI	Graphical User Interface
HBA	Host Bus Adapter
HH	Half Height
KMIP	Key Management Interoperability Protocol
LUN	Logical Unit Number
OCP	Operator Control Panel
NTP	Network Time Protocol
RMI	Remote Management Interface
SAN	Storage Area Network
SAS	Serial Attached SCSI
SMTP	Simple Mail Transfer Protocol
SNMP	Simple Network Management Protocol
SNTP	Simple Network Time Protocol
SSH	Secure Shell
SSL	Secure Socket Layer
UID	Unit Identification
USB	Universal Serial Bus
WORM	Write Once, Read Many
WWPN	World-Wide Port Name



# Technical Specifications

This appendix covers the technical specifications of the NEOxl 40 Tape Library.

## Topics in Technical Specifications:

- [Physical Specifications](#)
- [Environmental Specifications](#)
- [Electrical Specifications](#)
- [Regulatory Specifications \(CSA test conditions\)](#)
- [Default Settings](#)

## Physical Specifications

Characteristic	Product Alone	Packaged
Height*	10.5 in. (268mm)	24.2 in. (615mm)
Width*	18.7 in. (475mm)	31.5 in. (800mm)
Depth*	35.1 in. (892mm)	47.6 in. (1200mm)
Weight	Base Module: 44 lbs. (20kg)	Base Module: 66 lbs. (30kg)
	Expansion Module: 40 lbs. (18kg)	Expansion Module: 51 lbs. (20kg)

\* Inches (in.) rounded to the nearest tenth of an inch.

## Environmental Specifications

Characteristic	Specification
<b>Temperature</b>	
Operating	40 to 95 °F (5 to 35 °C)
Non-operating	-40 to 140 °F (-40 to 60 °C)
Recommended operating temperature	50 to 85 °F (10 to 30 °C)
Temperature shock immunity - maximum rate of change	18 °F (10 °C) per hour
<b>Miscellaneous</b>	
Dust concentration	less than 200 micrograms / cubic meter
Altitude	16,450 feet (5000 meters)

Characteristic	Specification
<b>Humidity</b>	
Operating	10% to 80% RH non-condensing
Non-operating	5% to 90% RH non-condensing

## Electrical Specifications

Characteristic	Specification
<b>Current</b>	5.0 - 3.5 A
<b>Voltage</b>	100 - 240 V 50/60 Hz
<b>Power</b>	350 W

## Regulatory Specifications (CSA test conditions)

**NOTE:** The CSA test conditions might differ from the product specification limits.

Characteristic	Tested condition or value
<b>Equipment mobility</b>	Stationary - rack mount
<b>Connection to the mains</b>	Pluggable - Type A
<b>Operating condition</b>	Continuous
<b>Access location</b>	Operator accessible
<b>Over voltage category (OVC)</b>	OVCII
<b>Mains supply tolerance (%) or absolute mains supply values</b>	-10%, +6%
<b>Tested for IT power systems</b>	No
<b>IT testing, phase-phase voltage (V)</b>	N/A
<b>Class of equipment</b>	Class I
<b>Considered current rating (A)</b>	20 A (branch circuit protection)
<b>Pollution degree (PD)</b>	PD 2
<b>IP protection class</b>	IPX0
<b>Altitude during operation</b>	Maximum 6,562 feet (2000 meters)
<b>Altitude of test laboratory</b>	125 feet (38 meters)
<b>Mass of equipment</b>	Maximum 55 lbs. (25kg)
<b>Manufacturer's Declared Ambient</b>	40 °C

## Default Settings

Parameter	Default Setting	Reset to Default?
<b>User Accounts</b>		
User login	User = "user" PW = (null)	NOT reset
Administrator login	User= "administrator" PW = "adm001"	NOT reset
Security Login	User = "security" PW = "sec001"	NOT reset
LDAP Configuration	Disabled	NOT reset
<b>Network configuration (eth0)</b>		
Host name	Blank	NOT reset
IP Address	(DHCP)	NOT reset
Subnet Mask	(DHCP)	NOT reset
Default Gateway	(DHCP)	NOT reset
Auto Negotiate	Enable	NOT reset
Speed	Auto	NOT reset
IPV4	Enabled	NOT reset
DHCPv4	Enabled	NOT Reset
IPV6	Disabled	NOT reset
IPv6 Prefix	Enabled	NOT reset
Static V6	Disabled	NOT reset
IPv6Method	Disabled	NOT reset
DHCPv6	Disabled	NOT reset
DNS1 and DNS2 Configuration for Ipv4	(DHCP)	NOT reset
DNS1 and DNS2 Configuration for IPv6	Disabled	NOT reset
<b>Network Access Services</b>		
Primary Network Interface (eth0)	Enabled	NOT reset
SSH	Disabled	NOT reset
HTTPS	Disabled	NOT reset
Self-Signed SSL Certificate	no file	NOT reset
Internal IP (eth1)	192.0.2.0/24	NOT reset
Secondary network (fallback)	Definable from range	NOT reset
Default controller IP	192.0.2.1	NOT reset
<b>Magazines &amp; Mailslots (I/O Station)</b>		

Parameter	Default Setting	Reset to Default?
Mailslots	Disabled	Yes
Magazines/Mailslots Allow user "User" access	Disabled	Yes
<b>Partitions</b>	Disabled (one underlying partition)	All deleted leaving a single partition
NTP/SNTP Setting	Disabled	NOT reset
Date	Blank or existing	NOT reset
Time	Blank or existing	NOT reset
Time Zone	GMT	NOT reset
<b>Email Notifications (SMTP)</b>	Disabled	Yes
<b>SNMP</b>		
SNMP v1, v2, v3	Disabled	Yes
<b>Licensed Features (need license for enablement)</b>		
Encryption KMIP	Disabled	NOT reset
<b>OCP Display Preferences</b>		
Screen Saver	Default image	Yes
Activation	10 minutes	Yes
Image	Customer specified	Yes
<b>SCSI Defaults</b>		
Product Name - Marketing Name		Yes
Library Product ID - INQUIRY Product ID String	MULTISTAK	Yes
Library Vendor ID - INQUIRY Vendor ID String	BDT	Yes
SCSI element addressing	Starting element addresses in decimal: Slot = 1001 Drives = 1 I/E Elements = 101  Values in hex are: Slot = 0x3E9 Drives = 0x1 I/E Elements = 0x65	Yes
<b>Miscellaneous settings</b>		
Barcode format returned to host	Align left	Yes



Parameter	Default Setting	Reset to Default?
Barcode length returned to host	8 left most characters	Yes
Language settings	English	NOT reset
Auto Clean	Disabled	Yes
Media Barcode Compatibility Check	Enabled	Yes
RMI Timeout	30 minutes	Yes
RMI Restricted Login	Disabled	Yes
<b>Drive Defaults</b>		
Drive speed and topology settings	Automatic/Automatic	Yes
Odometer	Enabled	NOT reset



# Master Glossary & Acronym List

**NOTE:** This is a general Overland Storage glossary and acronym list. Not all items may be found in this document or be used by this product.

## 1000BASE-T

1000BASE-T (also known as IEEE 802.3ab) is a standard for gigabit Ethernet over copper wiring. It requires, at a minimum, Category 5 cable (the same as 100BASE-TX), but Category 5e (Category 5 enhanced) and Category 6 cable may also be used and are often recommended. 1000BASE-T requires all four pairs to be present and is far less tolerant of poorly installed wiring than 100BASE-TX.

## Address

An address is a data structure or logical convention used to identify a unique entity, such as a particular process or network device.

## ADI

Short for *Automation/Drive Interface*. Media changer (automation) devices use a private communication link for monitoring and controlling removable medium devices (drives). The standard specifies a protocol for transporting commands, data, and status between automation devices and the drives.

## Algorithm

A sequence of steps designed to solve a problem or execute a process.

## ATA

Short for *Advanced Technology Attachment*. A standard interface for connecting storage devices to a PC.

## Authentication

The validation of a user's identity by requiring the user to provide a registered login name and corresponding password.

## Autonegotiation

An Ethernet feature that automatically negotiates the fastest Ethernet speed and duplex setting between a port and a hub or switch. This is the default setting and is recommended.

## Autosensing

An Ethernet feature that automatically senses the current Ethernet speed setting.

## Barcode

The machine-readable representation of a product code. Barcodes are read by a scanner that passes over the code and registers the product code. The width of black lines and white spaces between varies. Combinations of lines and spaces represent characters. Overland uses 3-of-9 code (Code 39) where each character is represented by 9 bars, 3 of which are wide.

## Bridging

Devices that connect and pass packets between two network segments that use different communications protocol.

## Bus or Channel

A common physical path composed of wires or other media, across which signals are sent from one part of a computer to another. A channel is a means of transferring data between modules and adapters, or between an adapter and SCSI devices. A channel topology network consists of a single cable trunk that connects one workstation to the next in a daisy-chain configuration. All nodes share the same medium, and only one node can broadcast messages at a time.

## CA

Short for *Certificate Authority*. A trusted third-party in a network that issues and manages security credentials.

## Cat 5 Cable

Short for *Category 5*, it is network cabling that consists of four twisted pairs of copper wire terminated by 8P8C modular connectors. CAT 5 cabling supports frequencies up to 100 MHz and speeds up to 100 Mbps. It can be used for ATM, token ring, 100BASE-T, and 10BASE-T networking.

Cat 5 is based on the EIA/TIA 568 Commercial Building Telecommunications Wiring Standard developed by the Electronics Industries Association as requested by the Computer Communications Industry Association in 1985.

## Cat 6 Cable

Short for *Category 6*, it is network cabling that consists of four twisted pairs of copper wire terminated by 8P8C modular connectors made to higher standards that help reduce noise caused by crosstalk and system noise. The ANSI/TIA-568-B.2-1 specification states the cable may be made with 22 to 24 AWG gauge wire, so long as the cable meets the specified testing standards.

It is designed for Gigabit Ethernet that is backward compatible with the Category 5/5e and Category 3 cable standards. Cat 6 features more stringent specifications for crosstalk and system noise. The cable standard provides performance of up to 250 MHz and is suitable for 10BASE-T, 100BASE-TX, and 1000BASE-T (Gigabit Ethernet).

## Channel

A communications path between two computers or devices.

## Checksum

The result of adding a group of data items that are used for checking the group. The data items can be either numerals or other character strings treated as numerals during the checksum calculation. The checksum value verifies that communication between two devices is successful.

## default gateway

The router used when there is otherwise no known route to a given subnet.

## DHCP

Short for *Dynamic Host Configuration Protocol*. A communications protocol that lets network administrators centrally manage and automate the assignment of IP addresses on a computer network. Each system that connects to the internet/intranet needs a unique IP address.

## Disaster Recovery

A strategy that allows a company to return to normal activities after a catastrophic interruption. Through failover to a parallel system or by restoration of the failed system, disaster recovery restores the system to its normal operating mode.

## DNS

Short for *Domain Name Service*. A network service that translates domain names into IP addresses using a server that maintains a mapping of all host names and IP addresses. Normally, this mapping is maintained by the system administrator, but some servers support dynamic mappings.

## Domain

A set of network resources in Windows 2000/2003/2008, such as users and groups of users. A domain may also include multiple servers on the network. To gain access to these network resources, the user logs into the domain.

## Domain Name

The ASCII name that identifies the domain for a group of computers within a network.

## Ethernet

The most widely installed LAN technology. 100BASE-T Ethernet provides transmission speeds of up to 100 Mbps. Fast Ethernet or 1000BASE-T provides transmission speeds up to 1000 Mbps and is typically used for LAN backbone systems, supporting workstations with 100BASE-T cards. Gigabit Ethernet (GbE) provides an even higher level of backbone support at 1000 Mbps (one Gigabit or one billion bits per second).

## Ethernet Address

The unique six-digit hexadecimal (0-9, A-F) number that identifies the Ethernet interface.

## Ethernet Port

The port on a network card to provide Ethernet access to the computer.

## Event

Any significant occurrence or error in the system that may require notifying a system administrator or adding an entry to a log.

## F\_Port

A *Fabric* port within a Fibre Channel switch that provides a point-to-point link to a single N\_Port. F\_Ports are intermediate ports in virtual point-to-point links between end ports. For example, N\_Port to F\_Port to F\_Port to N\_Port using a single Fibre Channel fabric switch.

## Fabric

A Fabric is a Fibre Channel (FC) that allows an active intelligent interconnection scheme to connect devices. Everything between the ports on an FC is called the Fabric. The Fabric is most often a switch or series of switches that takes the responsibility for routing.

## FC-AL

Short for *Fibre Channel Arbitrated Loop*. An FC-AL is a Fibre Channel network in which up to 126 systems and devices are connected in a loop topology, with each transmitter connecting to the receiver of the device on its logical right. The Fibre Channel Arbitrated Loop protocol used for transmission is different from Fibre Channel switched and point-to-point protocols. Multiple FC-AL loops can be connected via a fabric switch to extend the network.

## Fibre Channel

Fibre Channel (FC) is a gigabit-speed network technology which transports SCSI commands over Fibre Channel networks. Fibre Channel was primarily concerned with simplifying the connections and increasing distances, but later designers added the goals of connecting SCSI disk storage, providing higher speeds and far greater numbers of connected devices.

## Firmware

Software stored in read-only memory (ROM) or programmable ROM (PROM). Firmware is often responsible for the behavior of a system when it is first switched on.

## FL\_port

A *Fabric Loop* port within a Fibre Channel switch that is capable of Fibre Channel Arbitrated Loop operations and is connected to one or more NL\_Ports via a Fibre Channel Arbitrated Loop. An FL\_Port becomes a shared entry point for public NL\_Port devices to a Fibre Channel fabric. FL\_Ports are intermediate ports in virtual point-to-point links between end ports that do not reside on the same loop, for example NL\_Port to FL\_Port to F\_Port to N\_Port through a single Fibre Channel fabric switch.

## FTP

Short for *File Transfer Protocol*. A standard internet protocol that provides a way to exchange files between computers on the internet.

## Full-duplex

A type of transmission that allows communicating systems to both transmit and receive data simultaneously.

## Gateway

The hardware or software that bridges the gap between two network subnets. It allows data to be transferred among computers that are on different subnets.

## Gigabit Ethernet

Also known as GigE or GbE, this Ethernet standard uses a one Gigahertz (1000 Hz) clock rate to move data.

## HBA

Short for *Host Bus Adapter*. An HBA is an I/O adapter that sits between the host computer's bus and the Fibre Channel loop and manages the transfer of information between the two channels. To minimize the impact on host processor performance, the HBA performs many low-level interface functions automatically or with minimal processor involvement.

## Half-duplex

A type of transmission that transfers data in one way at a time.

**Host Name**

The unique name by which a computer is known on a network. It is used to identify the computer in electronic information interchange.

**Hot Swapping**

The ability to add or remove powered-off tape drives to or from a system without the need to power down or interrupt client access to filesystems. Not all components are hot-swappable. Please read installation and maintenance instructions carefully.

**HTTP**

Short for *Hypertext Transfer Protocol*. An application protocol for transferring files (text, graphic images, sound, video, and other multimedia files) over TCP/IP on the World Wide Web.

**HTTPS**

Short for *Hypertext Transfer Protocol Secure*. The HTTP protocol using a Secure Sockets Layer (SSL). SSL provides data encryption, server authentication, message integrity, and client authentication for any TCP/IP connection.

**I/E Element**

See [Mail Slot](#).

**Initiator Device**

An initiator normally runs on a host computer. It may be either a software driver or a hardware plug-in card, often called a Host Bus Adapter (HBA). A software initiator uses one of the computer's Ethernet ports for its physical connection, whereas the HBA will have its own dedicated port.

**IP**

Short for *Internet Protocol*. The unique 32-bit value that identifies the location of the server. This address consists of a network address, optional subnetwork address, and host address. It displays as four addresses ranging from 1 to 255 separated by periods.

**Kerberos**

A secure method for authenticating a request for a service used by ADS. Kerberos lets a user request an encrypted "ticket" from an authentication process that can then be used to request a service from a server. The user credentials are always encrypted before they are transmitted over the network.

In Windows 2000/XP, the domain controller is the Kerberos server. The Kerberos key distribution center (KDC) and the origin of group policies are applied to the domain.

**KMIP**

Short for *Key Management Interoperability Protocol*. A client/server communication protocol for storage and maintenance of key, certificate, and secret objects.

**LAN**

Short for *Local Area Network*. A network connecting computers in a relatively small area such as a building.

**LCD**

Short for *Liquid Crystal Display*. An electronic device that uses liquid crystal to display messages.

**LDAP**

Short for *Lightweight Directory Access Protocol*. An open, vendor-neutral, industry standard application protocol for accessing and maintaining distributed directory information services over an Internet Protocol (IP) network.

**LED**

Short for *Light-Emitting Diode*. An LED is a type of diode that emits light when current passes through it. Visible LEDs are used as indicator lights on electronic devices.

**Linux**

A Unix-like operating system that was designed to provide personal computer users a free or very low-cost operating system comparable to traditional and usually more expensive Unix systems.

**LTO**

Short for *Linear Tape-Open*, a technology that was developed jointly by HP, IBM, and Certance (Seagate) as an open standards. It is ideally suited for backup, restore, and archive applications, and provides reliability in both stand-alone and automated environments. The tape cartridges go by the label "Ultrium."

- Ultrium generation 3 (LTO-3) cartridge – up to 800 GB capacity and a transfer rate of 80 MB/s using 2.0:1 compression.
- Ultrium generation 4 (LTO-4) cartridge – up to 1.6 TB capacity and a transfer rate of 120 MB/s using 2.0:1 compression.
- Ultrium generation 5 (LTO-5) cartridge – up to 3.0 TB capacity and a transfer rate of 280 MB/s using 2.0:1 compression.
- Ultrium generation 6 (LTO-6) cartridge – up to 6.25 TB capacity and a transfer rate of 400 MB/s using 2.5:1 compression.
- Ultrium generation 7 (LTO-7) cartridge – up to 15.0 TB capacity and a transfer rate of 750 MB/s using 2.5:1 compression.
- Ultrium generation 8 (LTO-8) cartridge – up to 30.0 TB capacity and a transfer rate of 750 MB/s using 2.5:1 compression.

**LUN**

Short for *Logical Unit Number*. A SCSI or Fibre Channel device identifier. LUN is a subdivision of a SCSI target.

**LVD**

Short for *Low Voltage Differential*. LVD is a method of powering SCSI cables that will be formalized in the SCSI-3 specifications. LVD uses less power than the current differential drive (HVD), is less expensive, and allows for higher speeds such as those of Ultra-2 SCSI. LVD requires 3.3 volts (versus 5 volts for HVD).

## MAC Address

Short for *Media Access Control address*, a hardware address that uniquely identifies each node of a network. In the Open Systems Interconnection (OSI) model, one of two sublayers of the Data Link Control layer concerned with sharing the physical connection to the network among several computers. Each Ethernet port has a unique MAC address.

## Mail Slot

A configurable import/export slot or magazine to provide a means of exchanging tape media while the unit is still operating.

## Mapping table

A table indexed by sequential LUN values, indicating the selected BUS:TARGET:LUN devices. Mapping tables are used by routers and bridges like the GEOi to perform Ethernet-to-SCSI pathing.

## MD5 Algorithm

MD5 is a way to verify data integrity, and is much more reliable than checksum and many other commonly used methods.

## MIB

Short for *Management Information Base*. A formal description of a set of network objects that can be managed using the Simple Network Management Protocol (SNMP). The format of the MIB is defined as part of SNMP.

## N\_Port

A *Node* port connects via a point-to-point link to either a single N\_Port or a single F\_Port. N\_Ports handle creation, detection, and flow of message units to and from the connected systems. N\_Ports are end ports in virtual point-to-point links through a Fabric. For example, N\_Port to F\_Port to F\_Port to N\_Port using a single Fibre Channel fabric switch.

## NIC

Short for *Network Interface Card*. A board that provides network communication capabilities to and from a computer.

## NIS

Short for *Network Information Service*. It is a client–server directory service protocol for distributing system configuration data such as user and host names between computers on a computer network. Sun Microsystems developed NIS; the technology is licensed to virtually all other Unix vendors.

## NL\_port

A *Node Loop* port is capable of arbitrated loop functions and protocols. An NL\_Port connects via an arbitrated loop to other NL\_Port and at most a single FL\_Port. NL\_Ports handle creation, detection, and flow of message units to and from the connected systems. NL\_Ports are end ports in virtual point-to-point links through a fabric, for example NL\_Port to F\_Port to F\_Port to N\_Port using a single Fibre Channel fabric switch. In the absence of a fabric switch FL\_Port, NL\_Ports can communicate with other NL\_Ports in virtual point-to-point links through a FC-AL open loop circuit often through FC-AL (Arbitrated Loop) hub or loop switch devices.



**NTP**

Short for *Network Time Protocol*. A protocol for synchronizing the system clocks of computers over a packet-switched network.

**NVRAM**

Abbreviation of *Non-Volatile Random Access Memory*, a type of memory that retains its contents when power is turned off.

**OCP**

The *Operator Control Panel* is the front panel of a NEO XL-Series Base Module. It consists of an LCD display, navigation buttons, operation buttons, LEDs, and USB port.

**Permissions**

A security category, such as no access, read-only, or read-write, that determines what operations a user or group can perform on folders or files.

**Port Name**

This is an eight-byte hexadecimal number, uniquely identifying a single host [HBA](#) port. It incorporates the World Wide Name and two additional bytes that are used to specify the format and indicate the port number.

**Protocol**

A standardized set of rules that specifies the format, timing, sequencing, and/or error checking for data transmissions.

**PTP**

Short for *Point-to-Point*. PTP is the common mode of attachment to a single host. PTP is sometimes used to attach to a Fibre Channel switch for [SAN](#) connectivity.

**RMI**

The *Remote Management Interface* is a web interface for a NEO XL-Series library that provides access via a browser to all the library configurable features, includes online help, and is easier to use than the OCP.

**Router**

A router is a device that enables connectivity between Ethernet network segments.

**SAN**

Short for *Storage Area Network*. Data storage connected to a network that provides network clients access to data using block level protocols. To the clients, the data storage devices appear local rather than remote. An iSCSI SAN is sometimes referred to as an IP-SAN.

**SAS**

Short for *Serial Attached SCSI*. It is a point-to-point serial protocol that replaces parallel SCSI bus technology (multidrop) and uses the standard SCSI command set. It has no termination issues, supports up to 16,384 devices (using expanders), and eliminates clock skew. It consists of an Initiator that originates device service requests, a Target containing logical units that receives device service requests, and a Service Delivery Subsystem that transmits information between the Initiator and the Target.

## SCSI

Short for *Small Computer System Interface*. SCSI is an industry standard for connecting peripheral devices and their controllers to an initiator. Storage devices are daisy-chained together and connected to a host adapter. The host adapter provides a shared bus that attached peripherals use to pass data to and from the host system. Examples of devices attached to the adapter include disk drives, CD-ROM discs, optical disks, and tape drives. In theory, any SCSI device can be plugged into any SCSI controller.

### SCSI addressing

Each device supported by a SCSI adapter has its own unique SCSI address, which dictates the device's priority when arbitrating for access to the SCSI bus. A SCSI address of 7 has the highest priority. For a fast/wide SCSI adapter that supports up to 16 devices, the next highest priority address is 6, then 5, 4, 3, 2, 1, 0, 15, 14, 13, 12, 11, 10, 9, and 8. The narrow SCSI adapter supports up to eight devices, including itself. The SCSI address 7 has the highest priority, followed by 6, 5, 4, 3, 2, 1, and 0.

### SCSI bus

A SCSI bus provides a means of transferring data between SCSI devices. A SCSI bus is either an 8- or 16-bit bus that supports up to 8 or 16 devices, including itself. The bus can consist of any mix of initiators and targets, with the requirement that at least one initiator and one target must be present.

### SCSI device

A SCSI device is a single unit on a SCSI bus that originates or services SCSI commands. A SCSI device is identified by a unique SCSI address. SCSI devices can act as initiators or targets.

### SCSI port

A SCSI port is an opening at the back of a router that provides connection between the SCSI adapter and SCSI bus.

## SMB

Short for *Server Message Block*. A protocol for Windows clients. SMB uses the TCP/IP protocol. It is viewed as a complement to the existing internet application protocols such as FTP and HTTP. With SMB, you can access local server files, obtain read-write privileges to local server files, share files with other clients, and restore connections automatically if the network fails.

## SMTP

Short for *Simple Mail Transfer Protocol*. A TCP/IP protocol used for sending and receiving email.

## SNTP

Short for *Simple Network Time Protocol*. A TCP/IP protocol used for clock synchronization between computer systems over data networks.

## SNMP

Short for *Simple Network Management Protocol*. A system to monitor and manage network devices such as computers, routers, bridges, and hubs. SNMP views a network as a collection of cooperating, communicating devices, consisting of managers and agents.

## SSH

Short for *Secure Shell*. A service that provides a remote console for special system administration and customer support access to the server. SSH is similar to telnet but more secure, providing strong encryption so that no passwords cross the network in clear text.

## SSL

Short for *Secure Sockets Layer*. A protocol for managing the security of a message sent on the internet. It is a type of technology that provides data encryption, server authentication, message integrity, and client authentication for any TCP/IP connection.

## Standalone

A network bonding mode which treats each port as a separate interface. This configuration should be used only in multihomed environments in which network storage resources must reside on two separate subnets.

## Static IP Address

An IP address defined by the system administrator rather than by an automated system, such as DHCP.

## Storage Area Network

See [SAN](#).

## Subnet Mask

A portion of a network that shares a common address component. On TCP/IP networks, subnets are all devices with IP addresses that have the same prefix.

## Tape Cartridge

A magnetically coated strip of plastic in a plastic housing on which data can be encoded. Storing data on tapes is considerably cheaper than storing data on disks. Tapes also have large storage capacities, extending up to hundreds of gigabytes. They are generally used for long-term storage and backup, or for transporting large amounts of data. Tapes come in a variety of sizes and formats.

## Tape Drive

A device, that reads data from and writes it onto a tape.

## TCP/IP

Short for *Transmission Control Protocol/Internet Protocol*. The basic protocol used for data transmission over the internet.

## Telnet

A terminal emulation program for TCP/IP networks such as the Internet. The Telnet program runs on a computer and connects it to a server on the network. You enter commands through the Telnet program and they will be executed as if you were entering them directly on the server console. This enables you to control the server and communicate with other servers on the network. To start a Telnet session, you must log in to a server by entering a valid user name and password. Telnet is a common way to remotely control Web servers.

## Topology

Logical layout of the parts of a computer system or network and their interconnections. There are two types of topology: physical and logical. The physical topology of a network refers to the configuration of cables, computers, and other peripherals. Logical topology is the method used to pass the information between workstations.

## Trap

A signal from a device informing an SNMP management program that an event has occurred.

## U

A standard unit of measure for designating the height in computer enclosures and rack cabinets. One U equals 1.75 inches. For example, a 3U server chassis is 5.25 inches high.

## UDP

Short for *User Datagram Protocol*. A communications protocol for sending messages between computers in a network that uses the Internet Protocol (IP). UDP is an alternative to the Transmission Control Protocol but, unlike TCP, does not guarantee reliability or ordering of data packets.

## UPS

Short for *Uninterruptible Power Supply*. A device that allows a computer to keep running for a short time when the primary power source is lost. It also provides protection from power surges. A UPS device contains a battery that starts when the device senses a loss of power from the primary source.

## URL

Short for *Uniform Resource Locator*. A Web address.

## USB Port

USB is short for *Universal Serial Bus*. A USB port is a hardware interface for low-speed peripherals such as the keyboard, mouse, joystick, scanner, printer, and telephony devices.

## VLAN

Short for *Virtual LAN*. It consists of a network of computers that behave as if they are connected to the same wire - even though they may actually be physically connected to different segments of a LAN.

## Web Management Interface

A Web-based utility used for configuration and ongoing maintenance, such as monitoring server conditions, configuring email alerts for key events, or for SNMP management.

## Windows Domain Authentication

Windows-based networks use a domain controller to store user credentials. The domain controller can validate all authentication requests on behalf of other systems in the domain. The domain controller can also generate encrypted challenges to test the validity of user credentials. Other systems use encrypted challenges to respond to CIFS/SMB clients that request access to a share.

**WINS**

Short for *Windows Internet Naming Service*. The server that locates network resources in a TCP/IP-based Windows network by automatically configuring and maintaining the name and IP address mapping tables.

**Workgroup**

A collection of computers that are grouped for sharing resources such as data and peripherals over a LAN. Each workgroup is identified by a unique name.

## Symbols

> (menu flow indicator) **6**

## A

abbreviations **187**  
acronyms **187**  
alert definitions **6**

## B

Barcode Media ID Restriction **80**  
Basic Partition Wizard **89**

## C

Configuration  
    Encryption **93**  
    Mailslots **88**  
    Partitions **88**  
    User Accounts **93**  
configuration change events **184**  
conventions, typographical **6**  
Create Partition Scheme **91**  
CSA test conditions **189**

## D

default settings **190**  
defaults  
    drive **192**  
    email **191**  
    encryption **191**  
    KMIP **191**  
    magazines **190**  
    mailslots **190**  
    miscellaneous **191**  
    network access services **190**  
    network configuration **190**

OCP display **191**  
partitions **191**  
SCSI **191**  
SMTP **191**  
SNMP **191**  
    user account **190**  
drive defaults **192**

## E

electrical specifications **189**  
email defaults **191**  
enabling and disabling mailslots **88**  
enabling and disabling partitions **88**  
encryption **93**  
encryption defaults **191**  
environmental specifications **188**  
event  
    codes **173**  
event codes **173**  
events  
    configuration change **184**  
    informational **186**  
    warning **179**  
Expert Partition Wizard **91**

## F

Fibre Channel connection problems **160**

## I

informational events **186**  
Initial System Setup wizard **37, 53**

## K

KMIP defaults **191**

**L**

library tests 171

**M**

magazines defaults 190  
 mailslot for tapes 47  
 mailslots 88  
 mailslots defaults 190  
 manually accessing tape magazines 47  
 menu flow indicator 6  
 miscellaneous defaults 191

**N**

navigation buttons 43, 49  
 network access services defaults 190  
 network configuration defaults 190

**O****OCP**

Configuration menu 53  
 Home screen 44  
 Initial System Setup wizard 37, 53  
 layout 43, 49  
 LED indicators 43  
 log in 45  
 Logout menu 71  
 Maintenance menu 61  
 Operation menu 50  
 Status menu 68  
 OCP display defaults 191  
 operational problems  
 Attn LED 164  
 cleaning 166  
 inventory 165  
 media problems 164  
 OCP errors and alerts 162  
 power 162  
 RMI connection 165  
 tape movement 163

**P**

partitions 88  
 Basic Partition Wizard 89

Create Partition Scheme 91  
 Expert Partition Wizard 91

partitions defaults 191  
 performance problems  
 average file size 166  
 backup server 167  
 backup software 167  
 file storage system 166  
 host-disk connection 167  
 host-library connection 167  
 media 168  
 physical specifications 188  
 product documentation 8

**R**

regulatory specifications 189

**RMI**

Configuration Options 76  
 default Home page 73  
 Initial Configuration Wizard 76  
 Initial System Setup wizard 37, 53  
 log in 47  
 main screen 46  
 Maintenance Options 99  
 Operation Options 109  
 primary library interface 46  
 Status Options 113

**S**

SAS detection problems 161  
 SCSI defaults 191  
 Security user  
 Encryption 93  
 SMTP defaults 191  
 SNMP defaults 191  
 specifications  
 electrical 189  
 environmental 188  
 physical 188  
 regulatory 189

**T**

tape magazine  
 button 47  
 mailslot 47

manual access **47, 169**  
technical support **109**  
troubleshooting **160**  
typographical conventions **6**

## U

UID LEDs **108**  
unit identification **108**  
unlabeled media (allow/disallow) **80**  
unlocking magazines **168**  
user account defaults **190**  
user accounts **93**

## W

warning events **179**