



ArGest® Library

User's Guide TGL1800, TGL2240, TGL4480

FOR ANY QUESTIONS PLEASE CONTACT TOLIS GROUP SUPPORT www.tolisgroup.com/support

COPYRIGHT STATEMENT

TOLIS Group, Inc., et al

Copyright © 2001–2018 TOLIS Group, Inc. All rights reserved.

Your right to copy this manual is limited by copyright law. Making copies or adaptations without prior written authorization from TOLIS Group, Inc. is prohibited by law and constitutes a punishable violation of the law. To receive permission to reprint or copy information, contact brusales@tolisgroup.com.

NOTICE OF TRADEMARKS AND SERVICE MARKS

BRU, the TOLIS Group “three-man” Logo, and the BRU “circle b” Logo are trademarks or registered trademarks of TOLIS Group, Inc.

“Backup You Can Trust” and “BRU...Because it's the RESTORE that matters” are service marks of TOLIS Group, Inc.

The absence of a product, service name or logo from this list does not constitute a waiver of TOLIS Group's trademark or other intellectual property rights concerning that product, name or logo.

Throughout this book trademarks are used. TOLIS Group, Inc. states that we are using any and all trademarked names in an editorial fashion and to the benefit of the trademark owner with no intention of infringement of the trademark. For TOLIS Group legal information, please contact brulegal@tolisgroup.com.

NOTICE OF LIABILITY

The information in this manual is distributed “as is” and without warranty. While every precaution has been taken in the preparation of this book, TOLIS Group, Inc. nor its resellers and representatives shall have any liability to any person or entity with respect to any loss or damage caused or alleged to be caused directly or indirectly by the information and instructions contained in this manual or by the computer software and hardware described within.

TOLIS Group, Inc. may revise this publication from time to time without notice.

UPDATE INFORMATION

TOLIS Group, Inc. will always work to ensure that the data contained in this manual is kept up to date. As such, please visit our website at <http://www.tolisgroup.com> to retrieve the latest version of this manual.

PRINTING HISTORY

September 2018

IMPORTANT

The shipping lock must be removed for the robotics to work properly. A robot move error is displayed if the shipping lock is not removed. Retain the shipping lock for moving the library or shipping the library. Not using the shipping lock for library movement may damage the library and will result in a voiding of the warranty.

HEAVY LIFT WARNING!

When moving the Library, to reduce the risk of personal injury or damage to the device:

- Observe local health and safety requirements and guidelines for manual material handling.
- Remove all tapes to reduce the overall weight of the device and prevent cartridges from falling into the robotic path and damaging the Library.
- Obtain adequate assistance to lift and stabilize the device during the installation or removal.

RACK INSTALLATION WARNING

When placing the Library into a rack, to reduce the risk of personal injury or damage to equipment:

- Extend the rack leveling jacks to the floor.
- Ensure that the full weight of the rack rests on the leveling jacks.
- Install stabilizing feet on the rack.
- Extend only one rack component at a time. Racks may become unstable if more than one component is extended.

KEEP YOUR BOXES!

In the event that the library needs to be returned for warranty repair, the unit must be returned in the original packaging. Units that cannot be returned in the original packaging for any reason must have prior authorization from TOLIS Group or the RMA will be refused.

OBTAINING TECHNICAL SUPPORT

Technical support for the library is provided directly from TOLIS Group, Inc. See Appendix C for TOLIS Group Technical Support contact information.

**WARNING**

Indicates that failure to follow directions could result in bodily harm or death.

**CAUTION**

Indicates that failure to follow directions could result in damage to equipment or data.

**IMPORTANT**

Provides clarifying information or specific instructions.

**NOTE**

Provides additional information.

**TIP**

Provides helpful hints and shortcuts.

2.2 General Product Warnings

**DANGER**

High voltage

Risk of electric shock

- Do not remove covers (top, bottom or rear). No user-serviceable parts are inside.
 - Refer servicing to qualified service personnel.
-

**WARNING****Product Weight****Risk of personal injury**

Before lifting a library:

- Observe local health and safety requirements and guidelines for manual material handling.
- Remove all tapes to reduce the weight.
- Remove all tape drives to reduce the weight.
- Obtain adequate assistance to lift and stabilize the library during installation or removal.

Risk of damage to devices

When placing a library into or removing the library from a rack:

- Extend the rack's leveling jacks to the floor.
 - Ensure that the full weight of the rack rests on the leveling jacks.
 - Install stabilizing feet on the rack.
 - Extend only one rack component at a time.
-

**CAUTION****Static Sensitive****Risk of damage to devices**

- A discharge of static electricity damages static-sensitive devices or micro circuitry.
 - Proper packaging and grounding techniques are necessary precautions to prevent damage.
-

**NOTE**

- Ventilation – Place the product in a location that does not interfere with proper ventilation.
 - Heat – Place the product in a location away from heat sources.
 - Power sources – Connect the product to a power source only of the type directed in the operating instructions or as marked on the product.
 - Power cord protection – Place the AC line cord so that it is not possible to be walked on or pinched by items placed upon or against it.
 - Object and liquid entry – Insure that objects do not fall onto and that liquids are not spilled into the product's enclosure.
-

Table of Contents

1 - Panel Overviews and Location Requirements	8
Optional: Tabletop Conversion Cover or Desktop Feet.....	14
2 - Unpacking the Library	15
Identify Product Components.....	15
Removing and Storing the Shipping Lock.....	15
3 - Installation	16
Rack Mount Installation.....	16
Determine Your Rack Type	16
Securing the Rails to the Rack	16
Installing the Library	16
Desktop/Tabletop Installation.....	16
4 - Connecting the Library.....	17
Determine the Connection Type.....	17
Planning Configuration: SAS	17
Planning Configuration: Fibre-Channel.....	17
Direct Connection	17
SAN Connection	18
Planning the Configuration: Parallel SCSI	18
Changing the SCSI ID	18
Preparing the Host (Backup Server)	19
Connecting the Library: SAS.....	19
Connecting the Library: Fibre-Channel.....	19
Connecting a Second Tape Drive	20
Connecting the Library: Parallel SCSI	20
Connecting a Second Tape Drive	20
5 - Using the Operator Control Panel (OCP).....	21
Control Keys	21
LED Indicators	21
Powering on the Library	21
Configuring the Network	22
To configure an IPv4 address	22
To enable IPv6 and configure IPv6 addressing options OCP	23
Setting the Date and Time	23
Setting the Administrator Password	23
Loading Cartridges/Tapes	24
Unlocking the Mailslot (Unlock Mailslot)	25

6 - Using the Remote Management Interface (RMI)	26
Logging In	26
Status Icons	26
7 - Advanced Options & Additional Information	27
Configuring Logical Libraries (Partitioning)	27
Bar Code Reporting Format	27
Setting the Library Behavior	28
Powering a Drive On or Off	29
Magazine Release	30
Labeling Tape Cartridges	30
LTO Formatted Bar Codes	30
Updating the Firmware	31
Appendix A: Limited Hardware Warranty	32
Global Limited Warranty and Technical Support	32
Hardware Limited Warranty	32
General terms	32
Exclusions	34
Exclusive Remedy	34
Limitation of liability	35
Customer Responsibilities	35
Types of Hardware Warranty Service	36
Parts-only warranty service	36
Advanced unit replacement warranty service	36
Appendix B: OCP Menu Structure	37
Appendix C: TOLIS Group Technical Support	38
Appendix D: Ordering Media	39
Recommended Media	39
Purchase from TOLIS Group	39

1 - Panel Overviews and Location Requirements

Front Panel

(1U):

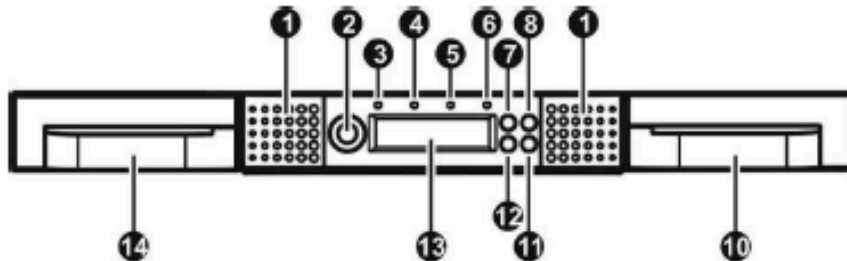

(2U):

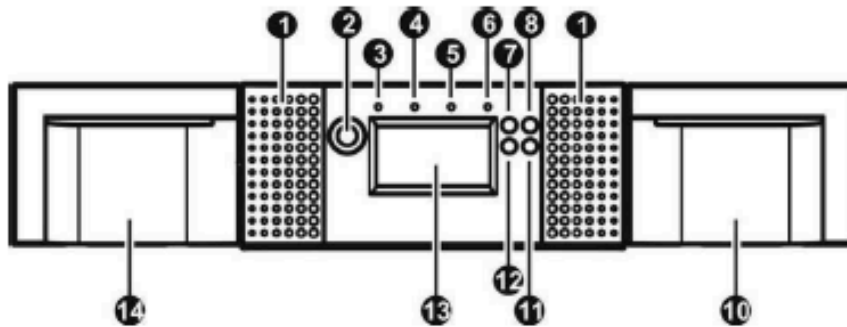

(4U):

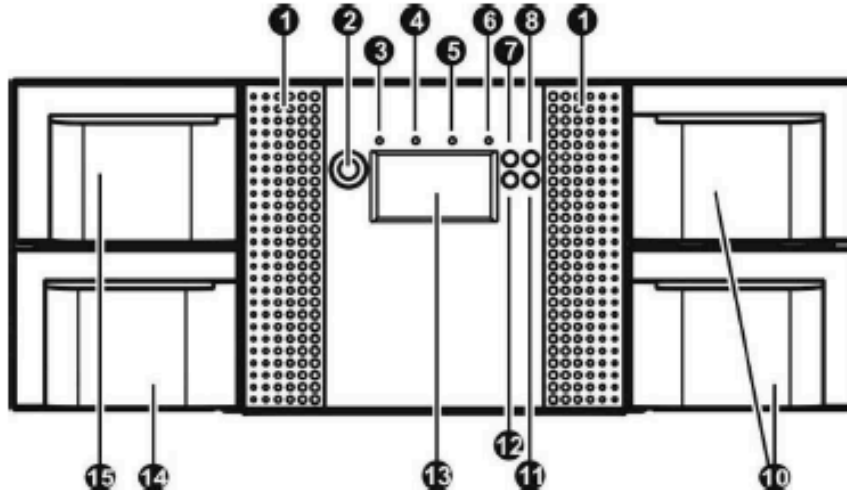

1	Air Vents	
2	Power Button	Pressing the button will initiate a controlled power down of the library (soft power down).
3	Ready LED, Green	Illuminated during power on; blinking during tape or library robotics activity.
4	Clean LED, Amber	Illuminated when the tape drive has determined that a cleaning tape should be used. Cleaning is only necessary when the library directs to do so. Additional cleaning is not necessary.
5	Attention LED, Amber	Illuminated when the library has detected a condition that requires attention by the operator.

6	Error LED, Amber	Illuminated when an unrecoverable tape drive or library error occurs. A corresponding error message is shown on the LCD screen.
7	Cancel Button [x]	Used to cancel a user action and return to the last menu item.
8	Previous Button [◀]	Used to navigate backward through menu items.
9	N/A	
10	Right Magazines	
11	Enter Button [-]	Used to enter to a sub menu or execute an action.
12	Next Button [▶]	Used to navigate forward through menu items.
13	Operator Control Panel	Consists of 128 x 64 characters. The OCP displays actions and status information, menu items or error messages equivalent to the operation mode.
14	Left Magazine with Mailslot	
15	Left Magazines	

Rear Panel

The rear panel of the NEO S-Series provides access to the drive interface connectors, the power connector, Ethernet, serial and USB ports, and the magazine release holes. All libraries support parallel SCSI, SAS, and Fibre channel tape drives.

The position of the appended devices on the rear panel is in all libraries common. The power supply is on the left side, tape drives are in the middle and the library controller is on the right side of the library.

(1U):

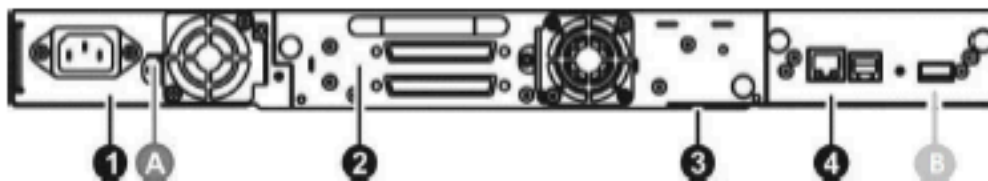

(2U/4U):

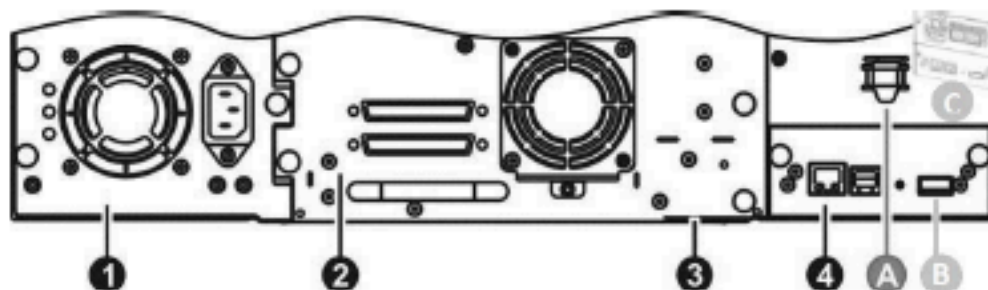

1	Power Supply	4	Library Controller
2	Tape Drives	A	Storage Location for Shipping Lock
3	Pull-out Tab with Serial Number	B	USB Port for Firmware Upgrades

Power Supplies

The power supply model utilized is dependent on the library model.

(1U):

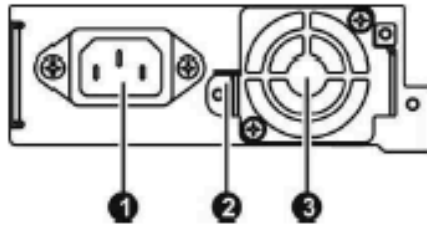

(2U):

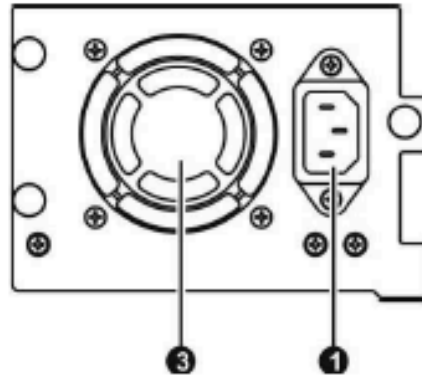

(4U):

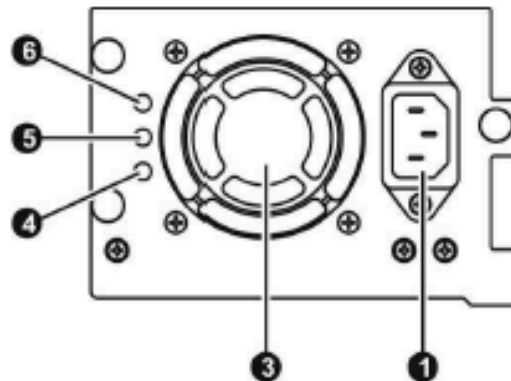

1	Power Connector (110/220 VAC)	4	LED (green) is illuminated when the power supply is producing good power for the library.
2	Storage Location for Shipping Lock	5	LED (amber) is illuminated when a fan failure occurs. The fan is running too slow or is defective.
3	Power Supply Fan Vent	6	LED (blue) is illuminated when the AC power is connected.

3.4.2 Tape Drive Back Panels

All figures are symbolic and the position of connectors, fan, etc. can vary on different drive types and generations.

SAS connectors all LTO generations:

Half-Height Tape Drives:

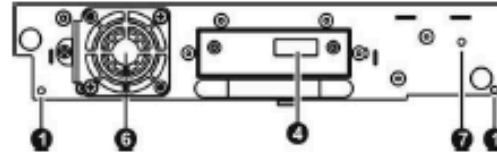
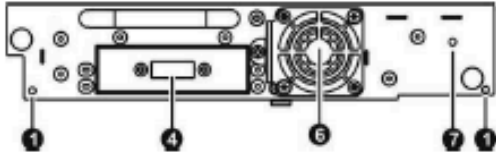

Half-Height Tape Drive with Ethernet Port:

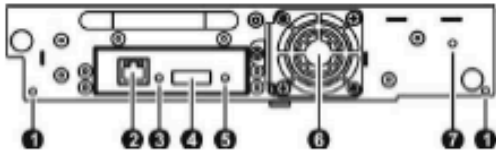

Half-Height Tape Drive with Two SAS Connectors:

1	Magazine Release Holes	5	Error LED (Amber)
2	Ethernet Port for Service/Diagnostics (not used)	6	Drive Fan Vent
3	Ready LED (Green)	7	Tape Drive LED
4	SAS Connectors		

FC connectors all LTO generations:

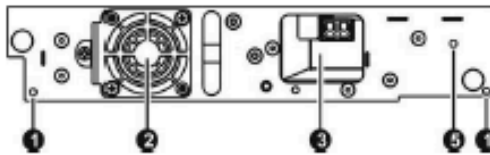

1	Magazine Release Holes	3	Ethernet Port for Service/Diagnostics (not used)
2	Drive Fan Vent	4	Tape Drive LED
3	FC Connectors		

Location Requirements



NOTE

- The library was designed for rack installation and must be installed using the provided rack rails. Installation on a table top or other similar surface could result in library operation errors.
- Select a rack with access to the host server.
- Choose a location that meets the criteria in the table below.

Location Requirements

Criteria	Definition
Rack requirements	Standard 19-inch rack with an appropriate # of U's (unit high) of clearance
Room temperature	10-35° C (50-95° F)
Power source	<ul style="list-style-type: none">• AC power voltage: 100-127 VAC; 200-240 VAC• Line frequency: 50-60 Hz• Place the library near to an AC outlet. The AC power cord is the libraries main AC disconnect device and must be easily accessible at all times.
Air quality	<ul style="list-style-type: none">• Place the library in an area with minimal sources of particulate contamination.• Avoid areas near frequently used doors and walkways, stacks of supplies that collect dust, printers, and smoke-filled rooms.• Excessive dust and debris can damage tapes and tape drive.
Humidity	20-80 percent RH non-condensing
Clearance	<ul style="list-style-type: none">• Back: Minimum of 15.4 cm (6 inches)• Front: Minimum of 30.8 cm (12 inches) – for mail slot Minimum of 60 cm to remove magazines (24 inches)• Sides: Minimum of 5.08 cm (2 inches)

Library Controller

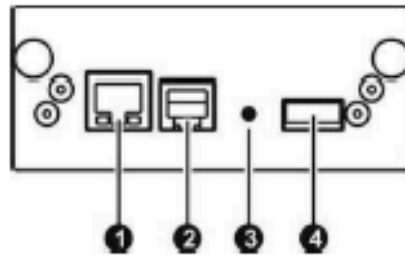

1	Ethernet Port (RMI Connection)
2	Serial Port (Engineering Diagnostics)
3	Controller LED (blinking = OK; if not blinking, failure)
3	USB Port (Firmware upgrades, key storage)

Ethernet Port

Ethernet port is only available on the library controller and connect the library to a network or PC for working w RMI. On some LTO5/6 tape drives, it is available for service/diagnostics (not used).

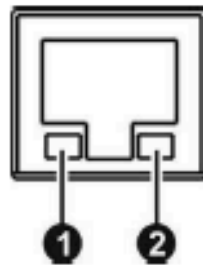

1	LED (amber) is illuminated when a connection is in place
2	LED (green) is illuminated when the connection is ready or in use

Optional: Tabletop Conversion Cover or Desktop Feet

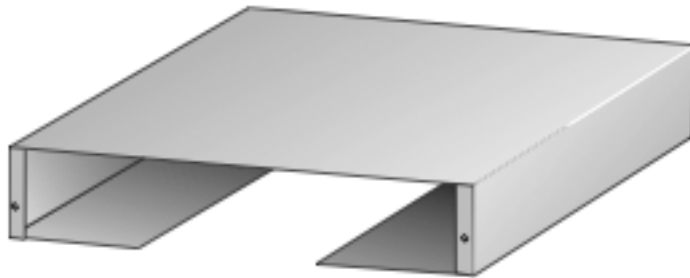

The Library should ONLY be installed into a rack with the enclosed rails, or installed into the optional tabletop conversion cover (TGL2240Library only), or with use of the specialized desktop feet (TGL1800 and TGL2240 only) and set on a flat surface. The TGL4480 is only designed to be used in a rack there are no desktop conversion options available.

VERY IMPORTANT: Please contact TOLIS Group Support for instructions on using the Desktop Feet or to inquire about the tabletop conversion kit. Using the library on a desk or shelf without the proper support of the feet or tabletop conversion kit may damage the library and void the warranty.

2 - Unpacking the Library

Remove the packaging, accessories, and Library from the box one layer at a time. Place the Library on a level work surface. Carefully remove the foam padding and then the bag from the Library. Save the packaging materials to move or ship the Library in the future.

Identify Product Components

Confirm that you received the following product components as per your order:

1. SAS, FC, or parallel SCSI cable(s) matching your LTO drive(s) type
2. Power cord
3. Power cord extension cable (select units only)
4. Two rack rails (ships in separate box)
5. Two packets of rack hardware
6. Product documentation is located online at tolisgroup.com

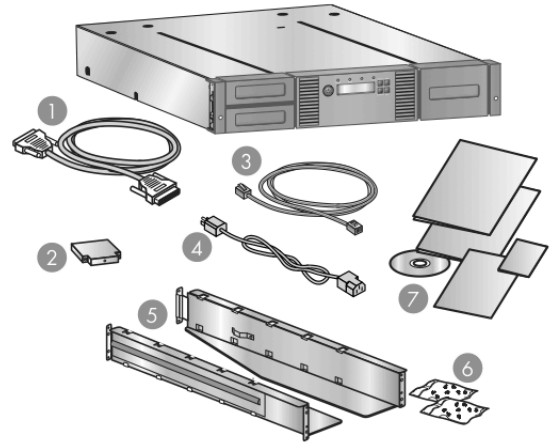

Removing and Storing the Shipping Lock

The shipping lock protects the robotic transport mechanism from moving during shipment and must be removed and stored before powering on the Library.

Locate the adhesive tape holding the storage lock at the top of the Library. Remove the adhesive tape, then remove the storage lock and store it as shown.

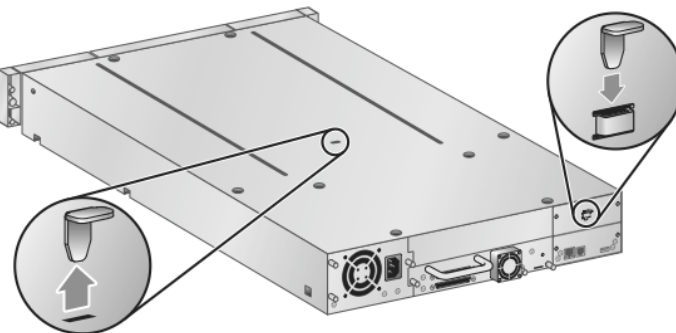

IMPORTANT:

The shipping lock must be removed for the robotics to work properly. A robot move error is displayed if the shipping lock is not removed. Always insert the shipping lock when moving or shipping the library to protect the internal robotics during movement. Failure to use the shipping lock when moving the library may damage the library and void the warranty.

3 - Installation

The is to be installed into a rack with a minimal rack depth of 26-inches (66.04 cm) if the Tabletop Conversion Cover or desktop feet are not being used. **DO NOT use the ArGest library on a flat surface without the Desktop Conversion Kit or desktop feet as the stress on the outside edges of the library will cause robotic failures and void the warranty.**

Rack Mount Installation

Determine Your Rack Type

You will need a #2 and #3 Phillips screwdriver, the two rack rails, and the packet of eight (8) M6 screws appropriate for your rack type.

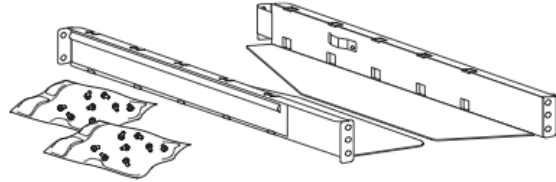

- The System/E rack has .71mm round holes in the rack column. Chose the bag labeled **HP Rack System/E**.
- The 5000 and 10000 racks have 9.5mm square holes in the rack column. Choose the bag labeled **HP Rack 5000, 10000**.

Securing the Rails to the Rack

Using the screws for your rack type and a #3 Phillips screwdriver, secure the front of one rail to the rack. Extend the rail and secure the back of the rail to the rack. Secure the other rail to the rack in the same manner.

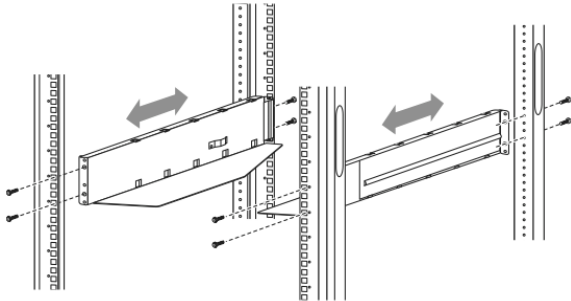

The front of the rails are straight and the back is angled as shown above.

Installing the Library

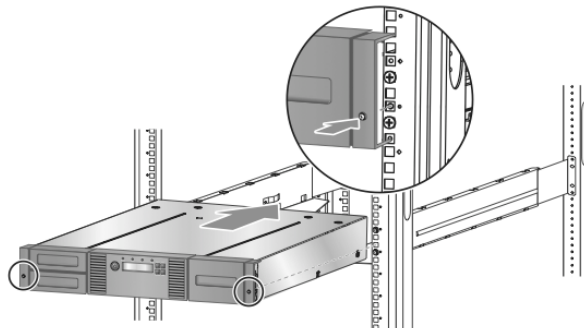

The library is installed by sliding the library onto the rails. Secure the library to the rack by using a #2 Phillips screwdriver to mounting the built-in screws in the front bezel to the rack. Tighten the captive screws on each side of the library.

Desktop/Tabletop Installation

Place the cover on the work surface behind the Library. Slide the Library into the cover until the front panel of the Library is aligned with the cover.

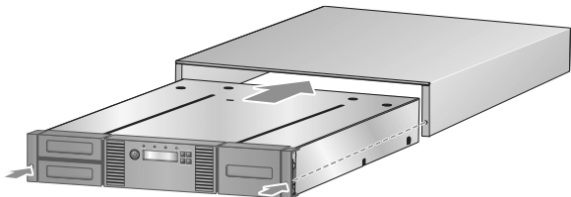

Tighten the two captive screws on the front bezel to secure the Library in the cover.

4 - Connecting the Library

The library is available in three different connectivity methods: SAS (default), parallel SCSI, and Fibre-Channel. Use the instructions below based on your library model.

The library is capable of using a maximum of one drive for the TGL1800, 2 drives for the Library, and 4 drives for the TGL4480. If more than one drives have been purchased with the library the connectivity of the two drives must be the same (i.e. SAS, FC, or parallel SCSI). It is not possible to mix the connectivity methods of different drives (i.e. Using a parallel SCSI drive in the bottom drive bay and a SAS drive in the top drive bay).



NOTE: *When using the library with multiple tape drives, the bottom drive is always the primary (first) drive. The top drive is the secondary (second) tape drive.*

Determine the Connection Type

See Chapter 1 to determine which type of drive connection the library is using. Once determined, use the steps below for the appropriate connection type.



NOTE: *With the release of the Ultrium 5 (LTO-5) tape technology, LTO-5 is not manufactured in the parallel SCSI interconnect type, only SAS and FC. The Ultrium 4 technology is the last release of LTO to support parallel SCSI interconnectivity.*

Planning Configuration: SAS

The server that the library is connecting to must have a SAS HBA with an external connector. TOLIS Group hardware bundles come with an HBA that must first be installed into the system the library will be connecting to. If this has not been done, please stop here and install the HBA into the system that the library will be directly connected to.



NOTE: *Most Serial Attached SCSI (SAS) RAID controllers do not support connection to tape devices. If you did not obtain your SAS HBA with your TOLIS Group hardware bundle, please make sure that the SAS HBA that the library will be connected to supports tape libraries on the operating system that is being used.*

Connecting the library to a SAS RAID controller that does not support tape libraries may prevent the system from being able to boot when the library is connected.

Planning Configuration: Fibre-Channel

The Fibre-Channel (FC) tape drive has two FC ports. Only one port may be used at a time, but both ports can be connected for path failover.



Direct Connection

You will need a 8Gb+ FC HBA. A 12Gb HBA is recommended for optimum performance, but is not required.

For Mac OS X systems that use the Apple Fibre-Channel Utility, direct connection of the library requires the port the library is plugged into to be set on a 1Gb Arbitrated loop to ensure proper communication to a tape library.

SAN Connection

All FC switches between the host and the library must be of the appropriate type. A 2Gb switch in the path may result in performance digression when backing up highly compressible data to a 4Gb tape drive.

All switches between the host and the library must be zoned appropriately so that the backup server and the library are the only devices in a single zone. Placing the library into a zone with other servers will cause intermittent connectivity problems and reduced performance. Connecting the tape library directly to the backup system does not require zoning of the FC switch.

Planning the Configuration: Parallel SCSI

If you are unfamiliar with configuring parallel SCSI devices, please contact TOLIS Group support.

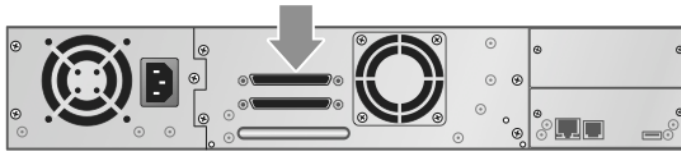

Follow these general guidelines when planning the SCSI configuration:

- The LTO-3 and LTO-4 TGS-series tape drives are Ultra320 parallel SCSI devices. Only put one LTO-3 or LTO-4 tape drive on an Ultra320 bus. Putting multiple LTO-3 or LTO-4 tape devices on a single Ultra320 bus will result in degraded performance. Do not connect a tape drive to an SE SCSI bus because it will seriously degrade performance.
- The LTO-2 tape drive is an Ultra160 parallel SCSI device. Up to two LTO-2 tape drives can share an Ultra320 bus or each tape drive can be on its own Ultra160 bus.
- Avoid putting the library on the same SCSI bus as a disk drive or SE device as it can result in degraded performance of the tape library and drive as well as any attached disk drives.
- The default SCSI ID of the bottom half-height or single full-height drive is 4. The default SCSI ID of the top half-height tape drive (if installed) is 5.



NOTE: *With the release of the Ultrium 5 (LTO-5) tape technology, LTO-5 is not manufactured in the parallel SCSI format. The Ultrium 4 technology is the last release of LTO to support the parallel SCSI format.*

Changing the SCSI ID

On a parallel SCSI library, if you need to change the SCSI ID for one or both of the tape drives, do so before connecting the library to the host computer.

1. Attach the power cord to the Library.
2. Remove the shipping lock if you have not already done so.
3. Power on the library by pressing the power button on on the front panel.
4. Once the library has become ready, on the front panel, press ENTER.
5. Press NEXT until the display shows `Configuration`. Press ENTER.
6. Press NEXT until the display shows `Change Drive 1` or `Change Drive 2`. Press ENTER to select the drive that needs a new SCSI ID.

7. Press NEXT until the display shows the desired new SCSI ID. Press ENTER to set the new SCSI ID of the selected drive.
8. Change the SCSI ID of the other tape drive if necessary.



NOTE: The SCSI ID can also be changed from the RMI (Configure -> Drive) screen once the RMI is configured.

Preparing the Host (Backup Server)

If you have not already done so, install the BRU backup software that was provided with your hardware bundle onto the system that will be managing the library tape library.

You'll also need to install the HBA into the same machine that the BRU software is being installed onto.

If an HBA that was not provided by TOLIS Group (purchased with the tape library), make sure that the SAS, FC or SCSI HBA being used supports tape devices on the operating system in which the HBA is being used. Also verify that the HBA being used supports multiple LUNs. For parallel SCSI devices, verify that multiple LUN support is enabled for the HBA and operating system.

Connecting the Library: SAS

The SAS cable that is provided with the Library tape library is a 4-meter one-to-four (1-4) fanout cable. The connections are all SFF-8088 mini-SAS connections.

This cable can be used to connect up to four tape drives to a single SAS HBA port. Any of the four tape drives can be used for any tape drive.

TOLIS Group also permits the cable to be used to connect third-party SAS devices such as RAID arrays or other non-TOLIS Group tape hardware. However, these additional devices may need to be removed for troubleshooting purposes when contacting TOLIS Group Technical Support concerning the Library tape library.

SAS signal rate require clean connections with a minimum number of connections between the HBA and the library. Do not use adapters or converters between the HBA and the tape library. TOLIS Group recommends a maximum SAS cable length of six (6) meters.

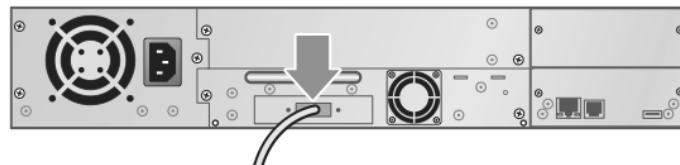
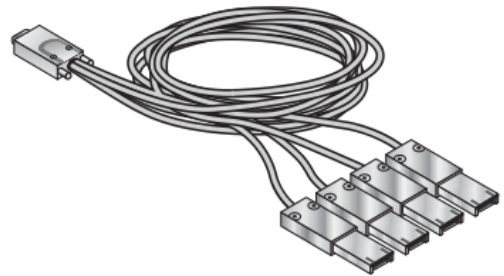

Attach the HBA end of the cable (the end with a single connection) to the SAS HBA installed into the BRU backup system. Attach a connector on the opposite end (one of the four) to each installed/attached tape drive.

The unused ends are single channel and not suitable for use with some disk arrays. Use the other ends to connect other tape devices or leave the ends capped and secure the loose connections to the rack to minimize stress on the connectors inserted into the tape drive(s).

Connecting the Library: Fibre-Channel

Remove the FC port dust cap from Port A. Attach the end of the FC cable to Port A on the tape drive. Attach the other end of the FC cable to a switch or HBA.

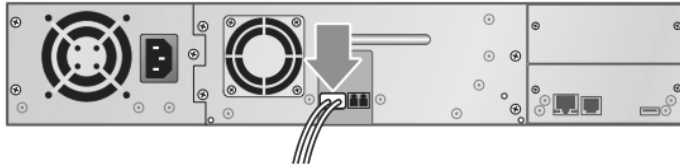

Make sure that if you are connecting the Library to a FC switch that you have read the Planning the Fibre-Channel Configuration at the beginning of this chapter.

Connecting a Second Tape Drive

Connect the second FC tape drive in the same manner as the first drive.

Connecting the Library: Parallel SCSI

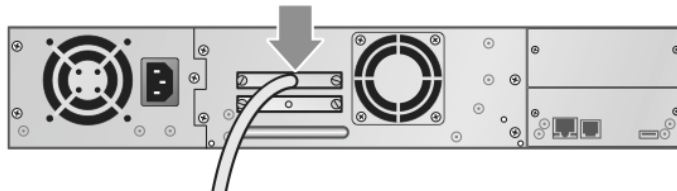

Attach one end of the parallel SCSI cable to the top parallel SCSI port on the tape drive. Attach the other end of the SCSI cable to the host bus adapter (HBA) or to the previous parallel SCSI device on the SCSI bus chain.

If the tape drive is the last device on the SCSI chain or is the only device on the SCSI bus, then a parallel SCSI terminator (included in hardware bundle) is required to be added to the bottom port of the parallel SCSI port on the drive.

Always make sure that the last device on a parallel SCSI chain is properly terminated.

Connecting a Second Tape Drive

If the Library has two parallel SCSI drives, attach one of a parallel SCSI cable to the HBA on the system. Attach the other end to the *bottom* port on the *bottom* tape drive.

Using another parallel SCSI cable, attach one end to the *top* port of the *bottom* tape drive. Attach the other end of the parallel SCSI cable to the *bottom* port of the *top* tape drive.

If the tape library is the only device or the last device on the parallel SCSI chain, use the provided parallel SCSI terminator to terminate the chain by attaching the terminator to the *top parallel SCSI* port of the *top* tape drive.

5 - Using the Operator Control Panel (OCP)

The OCP has a power button, four LEDs, four control keys and a 2-line by 16-character LCD screen. With the OCP, you can monitor, configure and operate most Library functions from the Library front panel.

Appendix B has the full OCP menu layout.

Control Keys

The OCP displays a menu that lets you access information and execute commands using the four control keys.

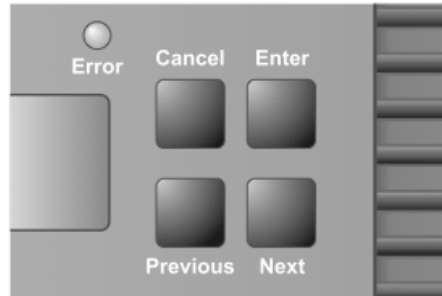

- Cancel — Cancels the current menu option, returns to the previous menu level, or returns to the Home screen.
- Enter — Executes the current menu or selects the current option displayed on the LCD screen.
- Previous — Selects the previous item or value in the currently displayed menu.
- Next — Selects the next item or value in the currently displayed menu.

LED Indicators

The OCP has four LEDs that provide information.

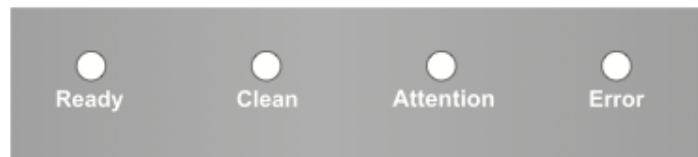

- Ready — Green, steady when power is on, blinking with tape drive or Library robotics activity.
- Clean — Amber when a tape drive cleaning operation is recommended.
- Attention — Amber if the Library has detected a condition that user attention is necessary, but that the device can still perform most operations.
- Error — Amber if an unrecoverable tape drive or Library error occurs. A corresponding error message displays on the LCD screen. User intervention is required; the device is not capable of performing some operations.

Powering on the Library

To use the web-based remote management interface (RMI), plug one end of the Ethernet cable into the Ethernet port on the back of the library. Plug the other end into an Ethernet LAN port.

Plug the power cable into the library and power outlet.

Power on the library using the power button located on the front panel. Check the LCD screen to make sure the library is receiving power.

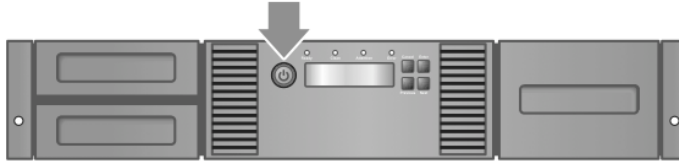

When the library has become ready, power on the backup server, if you have not already done so, any other devices you may have powered off prior to connecting the tape library.



NOTE: When the library is powered on for the first time after a new tape drive installation or replacement, the library will initialize the tape drive. This process can take a few minutes to complete.



NOTE: When powering on a parallel SCSI library, the backup system must be powered off and the library must completely finish the boot process before the system may be powered on. Otherwise, the library will not be reported to the backup system until the backup system is rebooted.

Configuring the Network

Configuring the network enables you to monitor, configure, and control certain library functions from the remote management interface (RMI). By default, the library will request an IP address from a DHCP server. You can configure the library to use a static IP address. Once the library has an IP address, you can change the network configuration from the OCP or RMI.

The library supports IPv4 and IPv6. By default, the library is configured to use IPv4, the most common current version. You can enable IPv6 or both Internet protocols from the OCP or RMI, and then finish configuring IPv6 from the RMI.



NOTE: To use the RMI, you must first setup the administrator password using the OCP. Until an administrator password has been set, you will not be able to login to the RMI.

To find the IP address obtained by DHCP:

1. From the Home screen, press NEXT until the display shows `Status/Information`. Press ENTER.
2. Press NEXT until the display shows `Network/Information`. Press ENTER.
3. Press NEXT until the display shows the IP address currently assigned.
4. Press CANCEL until the display is back at the Home screen.

To configure an IPv4 address

1. From the Home screen, press NEXT until the display shows `Configuration`. Press ENTER.
2. Press NEXT until the display shows `Configure Network Settings`. Press ENTER.
3. Press NEXT until the display shows `IPv4 Networking`. To change any IPv4 settings, press ENTER.
4. Press NEXT until the display shows the setting you want to change. Press ENTER to change the setting. Use the NEXT and ENTER keys to enter numbers. Press ENTER to confirm.
5. Repeat step 4 to configure additional IPv4 settings.

6. Press CANCEL until the display shows the Home screen.

To enable IPv6 and configure IPv6 addressing options OCP

1. From the Home screen, press NEXT until the display shows `Configuration`. Press ENTER.
2. Press NEXT until the display shows `Configure Network Settings`. Press ENTER.
3. Press NEXT until the display shows `IPv6 Networking`. To enable IPv6 or change any IPv6 settings, press ENTER.
4. Press NEXT until the display shows the setting you want to change. Press ENTER to change the setting. Use the NEXT and ENTER keys to enter numbers. Press ENTER to confirm.
5. Repeat step 4 to configure additional IPv6 settings.
6. Press CANCEL until the display shows the Home screen.

If you enabled IPv6, you must continue configuring IPv6 from the RMI after setting the administrator password (see using the OCP section in this guide). You can find the IPv6 IP address obtained by the library from the `OCPI nformation/Status -> Network Information` menu item.

Setting the Date and Time

This option sets the date and time used by the Library to record events and should be set during the initial installation process. You can also set the date and time from the RMI `Configure: System` screen.

Access to this feature requires the administrator password, if set.

To set the date and time from the OCP:

1. From the Home screen, press NEXT until the display shows `Library Date/Time`. Press ENTER.
2. Enter the administrator password, if requested.
3. A number in the year will flash. Click NEXT until the correct number is displayed. Click ENTER to accept the number. Repeat for each number in the date and time.
4. Press CANCEL until the display shows the Home screen.



NOTE: When setting the hours, the time is based on a 24-hour clock. There is no a.m. or p.m. designation. For example, 1:00 p.m. is 13:00.

Additionally, the time does not adjust itself for daylight savings time (DST); you must adjust the time through the front panel or web-based management interface.



NOTE: Setting the date and time of the library will have no effect to any backups being run by the BRU software. The BRU software runs schedule backup operations based on the date and time of the system on which BRU is installed. This includes any DST changes that are made since the operating system understands and adjusts accordingly.

Setting the Administrator Password

Setting an administrator password provides access to the administrator functions with the remote management interface (RMI) to only those people who know the administrator password. The administrator password must be exactly eight digits consisting of the numbers 0 (zero) through 9.

To set the administrator password:

1. On the front panel, press ENTER.
2. Press NEXT until the display shows `Configuration`. Press ENTER.

3. Press ENTER to change the administrator password.
4. The first number will flash. Press NEXT until the first number for the new password is displayed. Press ENTER to accept the number. The next number flashes. Repeat for each number in the password.
5. Press CANCEL until the display shows the Home screen.

Loading Cartridges/Tapes

Use the OCP `Operations -> Unlock Left Magazine` option to release the left magazine. Pull the magazine straight out of the front of the Library. You might be requested to provide the administrator password to access the magazines.

Insert the tape cartridges into the slots. By default, the slots are numbered 1 to 24, starting with the *bottom* front left slot.

To use the mailslot feature, leave the bottom slot in the front of the left magazine empty. The rest of the slot numbers are adjusted as shown.

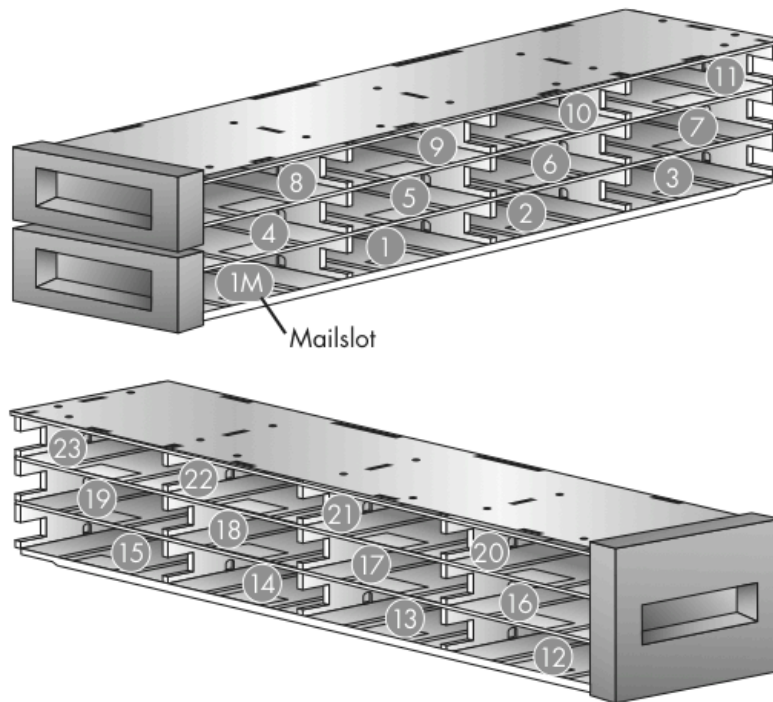

NOTE: *When the mailslot is disabled, the mailslot becomes slot 1 and all other slots are renumbered (i.e. slot 1 shown above becomes slot 2, slot 2 shown above becomes slot 3, etc.).*

Additionally, if the mailslot is enabled, it will not be an accessible slot to the BRU software. That means the total number of usable slots to BRU when the mailslot is enabled is 23.

Replace the magazine in the library. The library will inventory the left magazine for the changes that have been performed. Once the inventory is complete for the left side, the right magazine may be released using the `Operations -> Unlock Right Magazine` option.

The right magazine does not have a mailslot.

Unlocking the Mailslot (Unlock Mailslot)

The mailslot in the left magazine is used only with host system software that supports this feature. The mailslot feature allows you to insert or remove a single tape without removing the entire magazine. The benefit of using a mailslot is that the device will not inventory the rest of the slots in the magazine so the device can return to service sooner. The mailslot is in the left magazine.



NOTE: *The Unlock Mailslot menu is only displayed when the mailslot is enabled.*



To access the mailslot:

1. From the Home screen, press Next until the screen displays Unlock Mailslot.
2. Press Enter to select. The mailslot ejects automatically.
3. Pull the mailslot out to access the tape.
4. The screen displays Close Mailslot. Remove the tape cartridge from the mailslot and insert a different tape cartridge.

6 - Using the Remote Management Interface (RMI)

With the RMI, you can monitor, configure, and operate most Library functions from a web browser. The only tasks you cannot do from the RMI are:

- Opening the mailslots.
- Initiating the Wellness test.
- Saving and restoring configuration files, saving support tickets, and downloading firmware via a USB flash drive.

To enable the RMI, follow the instructions in this document to:

- Connect the Library to your local area network with an Ethernet cable.
- Configure the network settings of the Library.
- If you intend to use the administrative functions of the RMI, set the Administrator password using the OCP.



NOTE: *The Library is shipped without an administrator password. You must set the administrator password with the OCP before you can use the RMI administrator functions. Once the administrator password is set, you can access the RMI by providing the administrator password on the login screen.*

Logging In



Using the OCP, find the Library IP address from the Info > Network screen. Open any HTML web browser and enter the Library IP address. Select the account type. For the administrator account, you must also enter the administrator password. Click Sign In.

Once signed in, click Help in the upper right-hand corner for more information about the fields and information in the RMI.



NOTE: *The Library is shipped without an administrator password. You must set the administrator password with the OCP before you can use the RMI's administrator functions. Once the administrator password is set, you can access the RMI by providing the administrator password on the login screen.*

Status Icons

-  The green Status OK icon indicates that the Library is fully operational and that no user interaction is required.
-  The blue exclamation point **Status Warning** icon indicates that user attention is necessary, but that the device can still perform most operations.
- The red X **Status Error** icon indicates that user intervention is required and that the device is not capable of performing some operations.

7 - Advanced Options & Additional Information

The Library tape library has many advanced options for advanced users and special installation requirements. TOLIS Group suggests that these options remain unchanged unless explicitly told to change them by TOLIS Group Technical Support or your specific installation requires such changes.

Configuring Logical Libraries (Partitioning)

You can configure a Tape Library with multiple tape drives into logical libraries. Each logical library must contain at least one tape drive. Each logical library is configured independently, allowing use by different backup applications and with different backup policies. For example, one logical library could perform a backup operation for one department while the second logical library restores data for another department. Or, one logical library could have encryption enabled while another has encryption disabled. Data cartridges in one logical library cannot be shared with other logical libraries.

All logical libraries have access to the mailslot, if the mailslot is enabled. The Tape Library prohibits a cartridge that was placed in the mailslot by one logical library from being moved into another logical library. The Library allows a cartridge that was placed in the mailslot by the operator to be moved into any logical library. If sharing the mailslot among logical libraries is an issue in your environment, disable the mailslot.

Each logical library has a unique serial number and World Wide Identifier (WWID), which can be found in the RMI Identity: Library screen.

An Library Tape Library with two tape drives can be configured into two logical libraries. Each logical library is assigned one tape drive and one magazine, as shown.

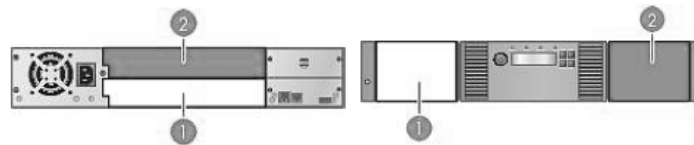

Use Set Logical Libraries to configure a two-drive Library into one or two logical libraries. Access to this feature requires the administrator password (if set).

To change the number of logical libraries:

1. From the Home screen, press PREVIOUS or NEXT until the screen displays `Configuration`. Press ENTER to select.
2. Press PREVIOUS or NEXT until the screen displays `Set Logical Libraries`. Press ENTER to select.
3. Enter the administrator password if prompted.
4. Press PREVIOUS or NEXT to scroll through the display until the desired number of logical libraries is displayed, then press ENTER.



NOTE: *If you have already installed the BRU software and have begun using the BRU software, you will need to perform a hardware scan in the BRU software to ensure that the BRU software sees the new hardware changes that have been made.*

Bar Code Reporting Format

You can configure how the tape bar code is displayed in the OCP and is reported to the BRU software. You can configure the number of display and the whether the numbers should be justified to the left or example, when reporting only six characters of the bar code label



RMI, and how it characters to right. For 12345678, if

alignment is left, the device will report 123456. If alignment is right, the device will report 345678. The default configuration is 8 Left. Access to this feature requires the administrator password (if set).

To configure the bar code report format:

1. From the Home screen, press PREVIOUS or NEXT until the screen displays `Configuration`. Press ENTER to select.
2. Press PREVIOUS or NEXT until the screen displays `Barcode Format Reporting`. Press ENTER to select.
3. Press PREVIOUS or NEXT until the screen displays either `Display Format Or Host Format`. The second line displays the number of characters and the current format. To change the current format, press ENTER to select either `Display` or `Host`. An example of the screen display is `# of characters 8`.
4. Press PREVIOUS or NEXT until the desired number of characters is listed. Press ENTER to select.
5. The screen displays either `Alignment Left` or `Alignment Right`. Use PREVIOUS or NEXT to toggle between the two choices. Press ENTER to select the correct alignment.
6. Press CANCEL until the Home screen is displayed.

Setting the Library Behavior

The Library supports three behavior modes: Random, Sequential, and Automatic. The Library automatically detects the required mode from the series of SCSI commands it receives; however, you can also change the mode. Choose the operating mode based on the capabilities of the software controlling the tape cartridges. The Library mode can be set independently for each logical library. Access to this feature requires the administrator password.

Random mode (BRU default): In Random mode, the device does not automatically load tapes into the tape drive; it waits for commands from the software or operator to load and unload tapes. Random mode is required by BRU, which is a full featured or a robotics-aware backup application.

CAUTION: *Changing from Random Mode will cause the BRU software to encounter errors and other tape change problems. The remaining information about library behavior is intended for informational purposes only.*

Sequential mode: In Sequential mode, the device automatically loads and unloads tapes from the drive. Sequential mode is used when the backup software is NOT robotics-aware or was designed for standalone drives only.

In Sequential mode, the Library will only use the lowest-numbered tape drive.

The operator begins the sequence by loading the desired tape into the tape drive. When a tape is unloaded for any reason, the device automatically removes the tape from the drive, returns it to its original slot, then loads the tape from the next available higher numbered slot.

To further determine how you want tapes loaded into the tape drive while in Sequential mode, you can set the Loop and Autoload options.

- When Autoload mode is set, the device automatically loads the cartridge from the lowest-numbered full slot into the tape drive. It then follows standard sequential operation. After configuring Autoload mode, you must do one of the following for Autoload mode to take effect:
 - Power cycle the device from the front panel.
 - Reboot the device from the RMI Support: Reboot screen.
 - Move the lowest-numbered cartridge to the drive before starting the backup application. If the mailslot is enabled, the lowest cartridge location will be in the mailslot.

- When Loop mode is on, the original first cartridge in the sequence is reloaded after the device has cycled through all available cartridges. If Loop mode is off and the last cartridge has been unloaded, the device stops loading cartridges until you load another manually.

CAUTION: Use caution when choosing Loop mode because it makes it possible to overwrite data on previously written cartridges.

When a Library is partitioned into logical libraries, each logical library operates as an independent library. Thus, the Library only loads tapes from the slots associated with one logical library into the tape drive associated with that logical library; it will not load tapes from slots associated with another logical library.

Automatic mode: In Automatic mode, the device switches from Sequential mode into Random mode when it receives certain SCSI commands.

To set a behavior mode:

1. From the Home screen, press PREVIOUS or NEXT until the screen displays `Configuration`. Press ENTER to select.
2. Press PREVIOUS or NEXT until the screen displays `Library Behavior`. Press ENTER to select.
3. Enter the administrator password if prompted.
4. Press PREVIOUS or NEXT until the screen displays `Library Mode`. Press ENTER.
5. The screen displays `Set Library Mode`, followed by the current Library mode: Random, Sequential, or Automatic. To change the mode, press ENTER.
6. Press PREVIOUS or NEXT to scroll through the screens for Automatic, Sequential, or Random. Press ENTER to select the Library mode.
7. If you enabled Sequential mode, you can configure the Autoload and Loop options:
 - a. Press PREVIOUS or NEXT until the screen displays `Autoload Mode Disable` or `Autoload Mode Enable`. To change the Autoload mode, press ENTER. The screen displays either `Disable Autoload Mode` or `Enable Autoload Mode`. Press PREVIOUS or NEXT to toggle between the enabled and disabled screens. Press ENTER to select the Autoload mode. The display shows the new Autoload mode.
 - b. Press PREVIOUS or NEXT until the screen displays either `Loop Mode Disable` or `Loop Mode Enable`. To change loop mode, press ENTER. The screen displays either `Enable Loop Mode` or `Disable Loop Mode`. Press PREVIOUS or NEXT to toggle between the enabled and disabled screens. Press ENTER to select the loop mode.

Powering a Drive On or Off

Use this option to power a drive on or off without interrupting power to the rest of the device and the second drive. This is typically used when replacing one drive in a two-drive configuration. Access to this feature requires the administrator password (if set).

To power on or off the drive or drives:

1. From the Home screen, press PREVIOUS or NEXT until the screen displays `Support`. Press ENTER to select.
2. Press PREVIOUS or NEXT until the screen displays `Power On/Off Drives`. Press ENTER to select.
3. Enter the administrator password, if prompted.

4. Press PREVIOUS or NEXT until the screen displays the drive you need to power on or off. The screen displays Drive 1. The second line in the display displays the current state, which is either Power ON or Power OFF.
5. To change the power status, press ENTER. The screen displays either Press Enter to Power off DRV 1, or Press Enter to Power on DRV 1. Press ENTER to select. The Ready LED blinks during the operations.

Magazine Release

When possible, release the magazines from the OCP or RMI. If you must remove the magazines from both sides of the Library at the same time or when the Library is not powered on:

1. Insert a straightened paper clip or small pin about 1.5 cm (0.6 inch) into the magazine release hole.
2. Pulls out the magazine from that side.

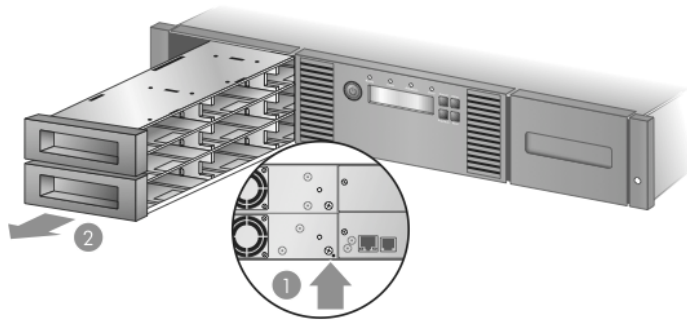

NOTE: Do not force the pin once you encounter resistance. Doing so may damage the library.

Labeling Tape Cartridges

Attaching a bar code label to each tape cartridge enables the Library and application software to identify the cartridge quickly, thereby speeding up inventory time. Make it a practice to use bar code labels on your tape cartridges.

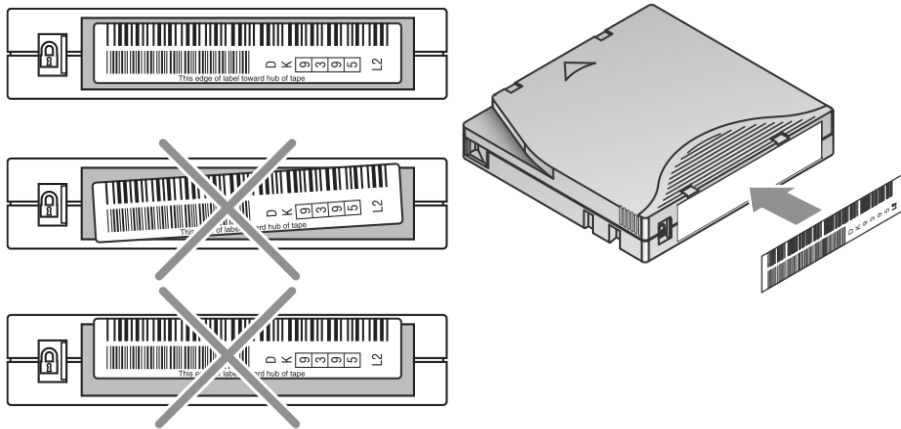

Ultrium tape cartridges have a recessed area located on the face of the cartridge next to the write-protect switch. Use this area for attaching the adhesive-backed bar code label. Only apply labels as designated.

LTO Formatted Bar Codes

If you are using the LTO formatted labels (shown at right), the alphanumeric text is to be placed as the top of the label. Applying the label upside down will cause the barcode reader in the Tape Library to have difficulty reading the barcode or it will fail to read the barcode all together.



Additionally, LTO formatted barcodes contain a media identifier on the label. Below is a sample bar code label. The label below is a color example of a LTO formatted label.



In the above sample bar code the barcode is “LT1260” and has a media identifier of “L4”. The “L4” designation is the shortened form of

Make sure that the bar code labels you are using are using the media identifier that matches your media type. For example, the above sample barcode is for LTO-4. The use of the above bar code label on non-LTO-4 media will cause problems with the tape library.

Updating the Firmware

With each new revision of the library firmware, TOLIS Group will provide the final revision on the TOLIS Group website at <http://www.tolisgroup.com/downloads/>. At no point should firmware be downloaded for a TOLIS Group tape device from any other website.

Upon release of new firmware, an announcement will be sent out on the HW-Updates mailing list as well as being provided in the TOLIS Group Knowledge Base (<http://knowledgebase.tolisgroup.com>). To subscribe to this Hardware Updates Only announcement list, send a subscription request to hw-updates-join@tolisgroup.com. You will receive a confirmation of subscription reply shortly. Once the subscription confirmation has been received any new announcements will be sent to the email address used to subscribe.

Firmware update instructions will be provided with each firmware download.

Appendix A: Limited Hardware Warranty

NOTE: This agreement is subject to change without notice. For the most up-to-date hardware warranty documentation, visit <http://www.tolisgroup.com>.

Global Limited Warranty and Technical Support

THIS GLOBAL LIMITED WARRANTY AND TECHNICAL SUPPORT STATEMENT PROVIDES IMPORTANT INFORMATION ABOUT THE NATURE AND SCOPE OF THE EXPRESS LIMITED WARRANTY PROVIDED FOR THE TOLIS GROUP PRODUCT, AND ALSO CONTAINS CERTAIN DISCLAIMERS AND LIMITATIONS OF LIABILITY BY TOLIS GROUP, WHICH MATERIALLY IMPACT YOUR RIGHTS. ACCORDINGLY, YOU ARE STRONGLY ADVISED TO CAREFULLY READ THIS GLOBAL LIMITED WARRANTY AND TECHNICAL SUPPORT STATEMENT BEFORE USING YOUR TOLIS GROUP PRODUCT. YOUR USE OF THE TOLIS GROUP PRODUCT IS DEEMED TO BE ACCEPTANCE OF THE TERMS AND CONDITIONS SET FORTH IN THIS GLOBAL LIMITED WARRANTY AND TECHNICAL SUPPORT STATEMENT.

Any guidance or direction TOLIS Group provides to you will only be based on the information provided by you to us as our customer. Many factors in your environment are unknown to TOLIS Group and can affect advice, problems, outcomes, or recommended solutions. TOLIS Group cannot and will not accept any culpability or responsibility due to potential omissions. Also, be advised that technology changes. As a result of these changes in technology, products you are using might be affected both directly and indirectly. TOLIS Group cannot and will not be responsible or liable for any consequences that can occur due to any change in technology, or in conjunction with the use of information provided by TOLIS Group under these circumstances. Proceeding with communications between yourself and TOLIS Group support is indication that you understand and agree with this statement.

Hardware Limited Warranty

General terms

This TOLIS Group Hardware Limited Warranty gives you, the customer, express limited warranty rights from TOLIS Group, the manufacturer. In addition, you may also have other legal rights under applicable local law or special written agreement with TOLIS Group.

TOLIS GROUP MAKES NO OTHER EXPRESS WARRANTY OR CONDITION WHETHER WRITTEN OR ORAL AND TOLIS GROUP EXPRESSLY DISCLAIMS ALL WARRANTIES AND CONDITIONS NOT STATED IN THIS LIMITED WARRANTY. TO THE EXTENT ALLOWED BY THE LOCAL LAW OF JURISDICTIONS OUTSIDE THE UNITED STATES, TOLIS GROUP DISCLAIMS ALL IMPLIED WARRANTIES OR CONDITIONS, INCLUDING ANY IMPLIED WARRANTIES OR CONDITIONS OF MERCHANTABILITY, MERCHANTABILITY, AND FITNESS FOR A PARTICULAR PURPOSE. FOR ALL TRANSACTIONS OCCURRING IN THE UNITED STATES, ANY IMPLIED WARRANTY OR CONDITION OF MERCHANTABILITY, SATISFACTORY QUALITY, OR FITNESS FOR A PARTICULAR PURPOSE IS LIMITED TO THE DURATION OF THE EXPRESS WARRANTY SET FORTH ABOVE. SOME STATES OR COUNTRIES DO NOT ALLOW.

A LIMITATION ON HOW LONG AN IMPLIED WARRANTY LASTS OR THE EXCLUSION OR LIMITATION OF INCIDENTAL OR CONSEQUENTIAL DAMAGES FOR CONSUMER PRODUCTS. IN SUCH STATES OR COUNTRIES, SOME EXCLUSIONS OR LIMITATIONS OF THIS LIMITED WARRANTY MAY NOT APPLY TO YOU.

FOR CONSUMER TRANSACTIONS IN AUSTRALIA AND NEW ZEALAND, THE LIMITED WARRANTY TERMS CONTAINED IN THIS STATEMENT, EXCEPT TO THE EXTENT LAWFULLY PERMITTED, DO NOT EXCLUDE, RESTRICT, OR MODIFY BUT ARE IN ADDITION TO THE MANDATORY STATUTORY RIGHTS APPLICABLE TO THE SALE OF THIS PRODUCT TO YOU.

THE LIMITED WARRANTY TERMS CONTAINED IN THIS STATEMENT, EXCEPT TO THE EXTENT LAWFULLY PERMITTED, DO NOT EXCLUDE, RESTRICT, OR MODIFY BUT ARE IN ADDITION TO THE MANDATORY STATUTORY RIGHTS APPLICABLE TO THE SALE OF THIS PRODUCT TO YOU.

This Limited Warranty is applicable in all countries and may be enforced in any country or region where TOLIS Group or its authorized service providers offer warranty service for the same product model number subject to the terms and conditions set forth in this Limited Warranty.

Under the TOLIS Group Global Limited Warranty program, products purchased in one country/region may be transferred to another country/region, where TOLIS Group or its authorized service providers offer warranty service for the same product model number, without voiding the warranty. Warranty terms, service availability, and service response times may vary from country/region to country/region. Standard warranty service response time is subject to change due to local parts availability. Your local TOLIS Group authorized service provider can provide you with details.

TOLIS Group is not responsible for any tariffs or duties that may be incurred in transferring the products. Transfer of the products may be covered by export controls issued by the United States or other governments.

This Limited Warranty applies only to TOLIS Group-branded hardware products (collectively referred to in this Limited Warranty as “TOLIS Group Hardware Products”) sold by or leased from TOLIS Group, Inc., its worldwide subsidiaries, affiliates, authorized resellers, or country distributors (collectively referred to in this Limited Warranty as “TOLIS Group”) with this Limited Warranty. The term “TOLIS Group Hardware Product” is limited to the hardware components and required firmware. The term “TOLIS Group Hardware Product” DOES NOT include any software applications or programs, non-TOLIS Group products, or non-TOLIS Group branded peripherals.

All non-TOLIS Group products or non-TOLIS Group branded peripherals external to the TOLIS Group Hardware Product—such as external storage subsystems, displays, printers and other peripherals—are provided “AS IS” without TOLIS Group warranty. However, non-TOLIS Group manufacturers and suppliers or publishers may provide their own warranties directly to you.

TOLIS Group warrants that the TOLIS Group Hardware Products that you have purchased or leased from TOLIS Group are free from defects in materials or workmanship under normal use during the Limited Warranty Period. The Limited Warranty Period starts on the date of purchase or lease from TOLIS Group, or from the date TOLIS Group completes installation. Your dated sales or delivery receipt, showing the date of purchase or lease of the product, is your proof of the purchase or lease date. You may be required to provide proof of purchase or lease as a condition of receiving warranty service. You are entitled to hardware warranty service according to the terms and conditions of this document if a repair to your TOLIS Group Hardware Product is required within the Limited Warranty Period.

Unless otherwise stated, and to the extent permitted by local law, new TOLIS Group Hardware Products may be manufactured using new materials or new and used materials equivalent to new in performance and reliability. TOLIS Group may repair or replace TOLIS Group Hardware Products (a) with new or previously used products or parts equivalent to new in performance and reliability, or (b) with equivalent products to an original product that has been discontinued. Replacement parts are warranted to be free from defects in material or workmanship for ninety (90) days or, for the remainder of the Limited Warranty Period of the TOLIS Group Hardware Product they are replacing or in which they are installed, whichever is longer.

During the Limited Warranty Period, TOLIS Group will, at its discretion, repair or replace any defective component. All component parts or hardware products removed under this Limited Warranty become the property of TOLIS Group. In the unlikely event that your TOLIS Group Hardware Product has recurring failures, TOLIS Group, at its sole discretion, may elect to provide you with (a) a replacement unit of TOLIS Group’s choosing that is the same or equivalent to your TOLIS Group Hardware Product in performance or (b) to give you a refund of your purchase price or lease payments (less interest) instead of a replacement. This is your exclusive remedy for defective products.

Any action related to this Agreement shall be governed by the substantive laws of the State of Arizona, without regard to conflicts of law principles. The State and Federal courts located in Maricopa County, Arizona, shall have sole jurisdiction over any dispute arising hereunder, and the parties hereby consent to the personal jurisdiction of such courts. Neither this Agreement, nor any rights hereunder, may be assigned by operation of law or otherwise, in whole in part, by

Client without the prior, written permission of TOLIS. Any sale of more than fifty percent (50%) of the common voting stock of, or other right to control, Client shall be deemed an assignment. Any purported assignment without such permission shall be void.

Any waiver of any rights of TOLIS under this Agreement must be in writing, signed by TOLIS, and any such waiver shall not operate as a waiver of any future breach of this Agreement. In the event any portion of this Agreement is found to be illegal or unenforceable, such portion shall be severed from this Agreement, and the remaining terms shall be separately enforced. The parties agree that any breach or threatened breach of this Agreement by Client is likely to cause TOLIS damage that is not fully reparable by payment of damages, and further agree that in such case TOLIS shall be entitled to seek and obtain injunctive or other equitable relief to protect its rights hereunder. Client's performance hereunder and use of the Software shall at all times comply with all applicable laws, rules and regulations, including those governing export of technical information, and Client shall fully indemnify, defend and hold harmless TOLIS against any violation thereof. This Agreement is the entire agreement between the parties with respect to this subject matter, and supersedes any and all prior or contemporaneous, conflicting or additional communications, negotiations or agreements.

Exclusions

TOLIS GROUP DOES NOT WARRANT THAT THE OPERATION OF THIS PRODUCT WILL BE UNINTERRUPTED OR ERROR-FREE. TOLIS GROUP IS NOT RESPONSIBLE FOR DAMAGE THAT OCCURS AS A RESULT OF YOUR FAILURE TO FOLLOW THE INSTRUCTIONS INTENDED FOR THE TOLIS GROUP HARDWARE PRODUCT.

This Limited Warranty does not apply to expendable or consumable parts and does not extend to any product from which the serial number has been removed or that has been damaged or rendered defective (a) as a result of accident, misuse, abuse, contamination, improper or inadequate maintenance or calibration or other external causes; (b) by operation outside the usage parameters stated in the user documentation that shipped with the product; (c) by software, interfacing, parts or supplies not supplied by TOLIS Group; (d) improper site preparation or maintenance; (e) virus infection; (f) loss or damage in transit; or (g) by modification or service by anyone other than (i) TOLIS Group, (ii) an TOLIS Group authorized service provider, or (iii) your own installation of TOLIS Group-approved parts if available for your product in the servicing country or region.

TOLIS GROUP IS NOT RESPONSIBLE FOR DAMAGE TO OR LOSS OF ANY PROGRAMS, DATA, OR REMOVABLE STORAGE MEDIA. TOLIS GROUP IS NOT RESPONSIBLE FOR THE RESTORATION OR REINSTALLATION OF ANY PROGRAMS OR DATA OTHER THAN SOFTWARE INSTALLED BY TOLIS GROUP WHEN THE PRODUCT IS MANUFACTURED.

TOLIS Group is not responsible for any interoperability or compatibility issues that may arise when (1) products, software, or options not supported by TOLIS Group are used; (2) configurations not supported by TOLIS Group are used; (3) parts intended for one system are installed in another system of different make or model.

Exclusive Remedy

TO THE EXTENT ALLOWED BY APPLICABLE LOCAL LAW, THESE TERMS AND CONDITIONS CONSTITUTE THE COMPLETE AND EXCLUSIVE WARRANTY AGREEMENT BETWEEN YOU AND TOLIS GROUP REGARDING THE TOLIS GROUP HARDWARE PRODUCT YOU HAVE PURCHASED OR LEASED. THESE TERMS AND CONDITIONS SUPERSEDE ANY PRIOR AGREEMENTS OR REPRESENTATIONS—INCLUDING REPRESENTATIONS MADE IN TOLIS GROUP SALES LITERATURE OR ADVICE GIVEN TO YOU BY TOLIS GROUP OR AN AGENT OR EMPLOYEE OF TOLIS GROUP—THAT MAY HAVE BEEN MADE IN CONNECTION WITH YOUR PURCHASE OR LEASE OF THE TOLIS GROUP HARDWARE PRODUCT. No change to the conditions of this Limited Warranty is valid unless it is made in writing and signed by an authorized representative of TOLIS Group.

Limitation of liability

IF YOUR TOLIS GROUP HARDWARE PRODUCT FAILS TO WORK AS WARRANTED ABOVE, TOLIS GROUP'S MAXIMUM LIABILITY UNDER THIS LIMITED WARRANTY IS EXPRESSLY LIMITED TO THE LESSER OF THE PRICE YOU HAVE PAID FOR THE PRODUCT OR THE COST OF REPAIR OR REPLACEMENT OF ANY HARDWARE COMPONENTS THAT MALFUNCTION IN CONDITIONS OF NORMAL USE.

EXCEPT AS INDICATED ABOVE, IN NO EVENT WILL TOLIS GROUP BE LIABLE FOR ANY DAMAGES CAUSED BY THE PRODUCT OR THE FAILURE OF THE PRODUCT TO PERFORM, INCLUDING ANY LOST PROFITS OR SAVINGS, BUSINESS INTERRUPTION, LOSS OF DATA, LOST REVENUE, LOSS OF USE, OR ANY OTHER COMMERCIAL OR ECONOMIC LOSS OF ANY KIND, OR SPECIAL, INCIDENTAL, OR CONSEQUENTIAL DAMAGES. TOLIS GROUP IS NOT LIABLE FOR ANY CLAIM MADE BY A THIRD PARTY OR MADE BY YOU FOR A THIRD PARTY.

THIS LIMITATION OF LIABILITY APPLIES WHETHER DAMAGES ARE SOUGHT, OR A CLAIM MADE, UNDER THIS LIMITED WARRANTY OR AS A TORT CLAIM (INCLUDING NEGLIGENCE AND STRICT PRODUCT LIABILITY), A CONTRACT CLAIM, OR ANY OTHER CLAIM. THIS LIMITATION OF LIABILITY CANNOT BE WAIVED OR AMENDED BY ANY PERSON. THIS LIMITATION OF LIABILITY WILL BE EFFECTIVE EVEN IF YOU HAVE ADVISED TOLIS GROUP OR AN AUTHORIZED REPRESENTATIVE OF TOLIS GROUP OF THE POSSIBILITY OF ANY SUCH DAMAGES OR EVEN IF SUCH POSSIBILITY WERE REASONABLY FORESEEABLE. THIS LIMITATION OF LIABILITY, HOWEVER, WILL NOT APPLY TO CLAIMS FOR PERSONAL INJURY.

THIS LIMITED WARRANTY GIVES YOU SPECIFIC LEGAL RIGHTS. YOU MAY ALSO HAVE OTHER RIGHTS THAT MAY VARY FROM STATE TO STATE OR FROM COUNTRY TO COUNTRY. YOU ARE ADVISED TO CONSULT APPLICABLE STATE OR COUNTRY LAWS FOR A FULL DETERMINATION OF YOUR RIGHTS.

Customer Responsibilities

To enable TOLIS Group to provide the best possible support and service during the Limited Warranty Period, you will be required to:

- Maintain a proper and adequate environment, and use the TOLIS Group Hardware Product in accordance with the instructions furnished.
- Verify configurations, load most recent firmware, install software patches, run TOLIS Group diagnostics and utilities, and implement temporary procedures or workarounds provided by TOLIS Group while TOLIS Group works on permanent solutions.
- Allow TOLIS Group to keep resident on your systems or sites certain system and network diagnosis and maintenance tools to facilitate the performance of warranty support (collectively referred to as "Proprietary Service Tools"); Proprietary Service Tools are and remain the sole and exclusive property of TOLIS Group. Additionally, you will:
 - Use the Proprietary Service Tools only during the applicable warranty period and only as allowed by TOLIS Group – Install, maintain, and support Proprietary Service Tools, including any required updates and patches – Provide remote connectivity through an TOLIS Group-approved communications line, if required – Assist TOLIS Group in running the Proprietary Service Tools
 - Use the electronic data transfer capability to inform TOLIS Group of events identified by the software
 - Return the Proprietary Service Tools or allow TOLIS Group to remove these Proprietary Service Tools upon termination of warranty support
 - Not sell, transfer, assign, pledge, or in any way encumber or convey the Proprietary Service Tools
- In some cases, TOLIS Group may require additional software such as drivers and agents to be loaded on your system in order to take advantage of these support solutions and capabilities.
- Use TOLIS Group remote support solutions where applicable. TOLIS Group strongly encourages you to use available support technologies provided by TOLIS Group. If you choose not to deploy available remote support capabilities, you may incur additional costs due to increased support resource requirements.

- Cooperate with TOLIS Group in attempting to resolve the problem over the telephone. This may involve performing routine diagnostic procedures, installing additional software updates or patches, removing third-party options, and/or substituting options.
- Make periodic backup copies of your files, data, or programs stored on your hard drive or other storage devices as a precaution against possible failures, alteration, or loss. Before returning any TOLIS Group Hardware Product for warranty support, back up your files, data, and programs, and remove any confidential, proprietary, or personal information.
- Maintain a procedure to reconstruct your lost or altered files, data, or programs that is not dependent on the TOLIS Group Hardware Product under warranty support.
- Perform additional tasks as defined within each type of warranty service listed below and any other actions that TOLIS Group may reasonably request in order to best perform the warranty support.

Types of Hardware Warranty Service

Listed below are the types of warranty services that may be applicable to the TOLIS Group Hardware Product you have purchased. For more details, refer to the Limited warranty period section.

Parts-only warranty service

Your TOLIS Group Limited Warranty may include a parts-only warranty service. Under the terms of parts-only service, TOLIS Group will provide replacement parts free of charge. If TOLIS Group carries out the repair, labor and logistics costs are at your expense.

Advanced unit replacement warranty service

Your TOLIS Group Limited Warranty may include an advanced unit replacement warranty service. Under the terms of the advanced unit replacement warranty service, TOLIS Group will ship a replacement unit directly to you if the TOLIS Group Hardware Product you purchased is diagnosed as defective. On receiving the replacement unit, you will be required to return the defective unit back to TOLIS Group, in the packaging that arrives with the replacement unit, within a defined period of time, normally seven (7) calendar days. TOLIS Group will incur all shipping and insurance costs for ground delivery to you, however, shipping, insurance and logistic charges for return of the defective unit to TOLIS Group are your responsibility. Second-day, next-day and same-day delivery options are also available for for an additional charge.

For advanced unit replacement warranty, a valid credit card is required. TOLIS Group reserves the right to place a hold on the provided credit card for the full replacement cost of the replacement unit. If the defective unit has not been received by TOLIS Group after fourteen (14) calendar days, the credit card provided will be charged the full replacement cost of the replacement unit.

Appendix B: OCP Menu Structure

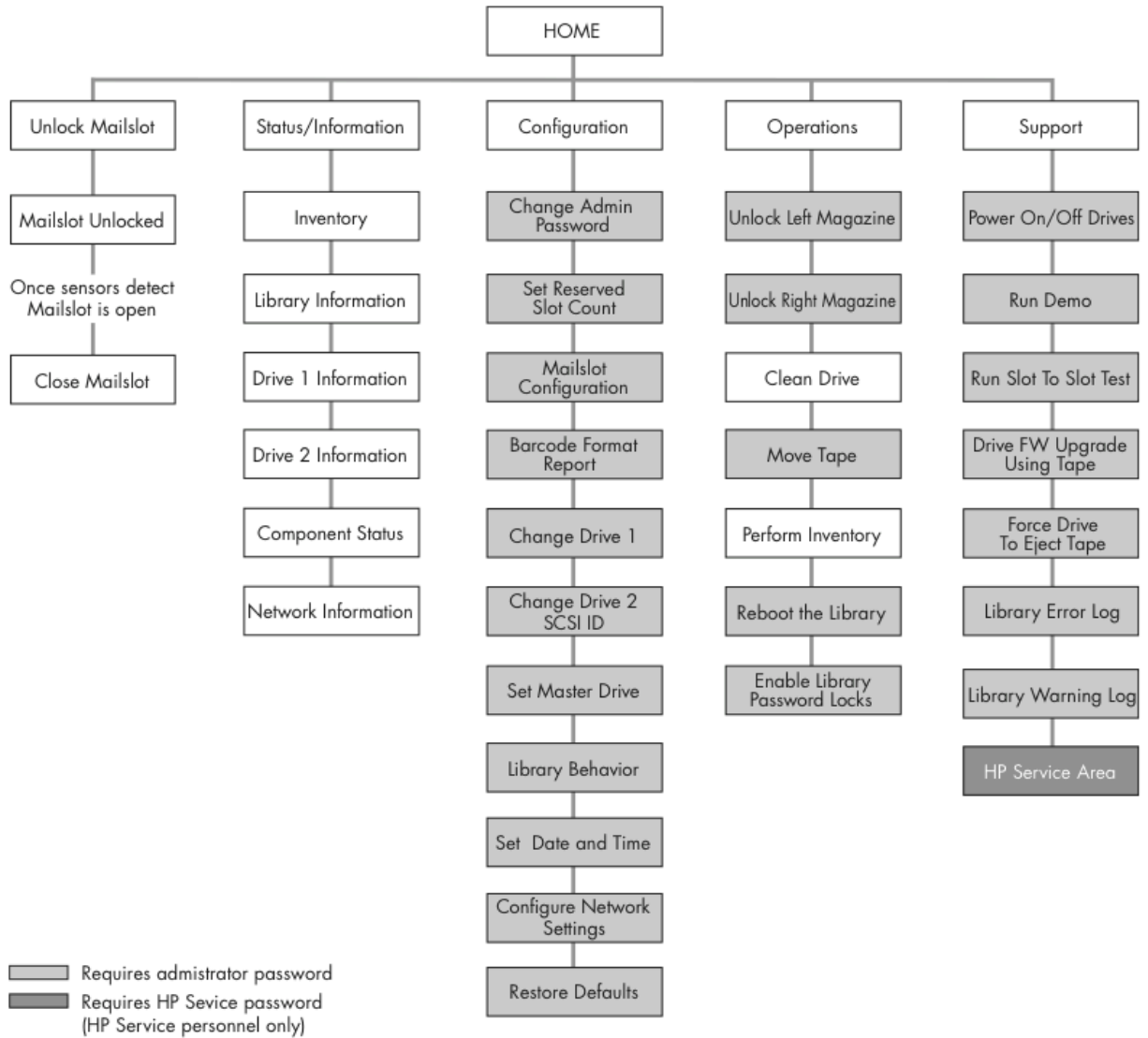

Appendix C: TOLIS Group Technical Support

All technical support for the TOLIS Group hardware bundles, including all TOLIS Group tape devices, HBAs purchased from TOLIS Group, and the BRU family of software is provided by TOLIS Group directly.

Any guidance or direction TOLIS Group provides to you will only be based on the information provided by you to us as our customer. Many factors in your environment are unknown to TOLIS Group and can affect advice, problems, outcomes, or recommended solutions. TOLIS Group cannot and will not accept any culpability or responsibility due to potential omissions. Also, be advised that technology changes. As a result of these changes in technology, products you are using might be affected both directly and indirectly. TOLIS Group cannot and will not be responsible or liable for any consequences that can occur due to any change in technology, or in conjunction with the use of information provided by TOLIS Group under these circumstances. Proceeding with communications between yourself and TOLIS Group support is indication that you understand and agree with this statement.

To contact TOLIS Group Technical Support, please make sure you have the following available:

1. A current support agreement. TOLIS Group hardware bundles ship with 13-months of technical support for the BRU software. It must be renewed annually.
2. Product Serial Number (Format: 1234-5678). We cannot accept support inquiries without your product serial number. Voicemail's left that request a call back without a serial number cannot be returned if a valid serial number is not provided on the voicemail.
3. Tape library/drive serial number that is in the product documentation that was provided with your hardware bundle. The number usually starts with "81" and in the format of 81XX-XXXX.
4. OS and Version / Kernel that the BRU software is installed on.
5. Administrative Access to all machines in question for your call.
6. A valid e-mail address that TOLIS Group Technical Support may use — this is required so support representatives may log your phone call.

Hours:

M-F: 9:00 a.m. – 5:00 p.m. MST (Arizona, U.S.A. — GMT -0700)

Phone: +1 (480) 505-1814

Fax: +1 (480) 505-0492

WWW: <http://tolisgroup.com/support>



NOTE: *The technical support agreement response time commitment is within 24 business hours Monday thru Friday excluding holidays. Typical response times are usually faster.*



TIMEZONE NOTICE: *Arizona does not observe Daylight Saving Time (DST). Arizona is always on Mountain Standard Time (MST), as opposed to Mountain Daylight Time (MDT). When DST is in effect, if it's 10 a.m. EDT in New York, it's 7 a.m. MST in Arizona. During the rest of the year, when DST is not in effect, if it's 10 a.m. EST in New York, then it's 8 a.m. MST in Arizona.*

Appendix D: Ordering Media

Recommended Media

When purchasing new media for your TOLIS Group tape device, TOLIS Group recommends the following brands of LTO media:

- Fujifilm
- HP

Purchase from TOLIS Group

TOLIS Group provides Fujifilm or HP, media when purchasing a TOLIS Group hardware bundle. When additional media needs to be purchased, including cleaning tapes, TOLIS Group provides direct-purchase abilities to all end-users for additional media.

Cartridge Type	Native Capacity	Part Number
LTO-6 Data Grade	2.5TB	LTO6Tape
LTO-7 Data Grade	6TB	LTO7Tape
LTO-8 Data Grade	12TB	LTO8Tape
LTO Universal Cleaning	60 Cleans	CLNATape



NOTE: Due to the ever changing pricing of LTO media, please contact BRU Sales for a free quote.

Volume discounts are also available.